

**ИНСТРУКЦИЯ ПО УСТАНОВКЕ И
ТЕХНИЧЕСКОМУ ОБСЛУЖИВАНИЮ
У-ФИЛЬТР 83700**

**INSTALLATION, SERVICE AND MAINTENANCE
INSTRUCTIONS**

Y-FILTER 83700



11.106.32.0001

c/Telers, 54 Aptdo. 174
E-17820 Banyoles
Girona (Spain)



Original Manual
11.106.30.00EN
(B) 2013/05

EC DECLARATION OF CONFORMITY

Manufacturer:

c/ Telers, 54
17820 Banyoles (Girona) - SPAIN

We hereby declare that the following products:

FILTER	Y-FILTER - 83700
Name	Type

conform with the provisions of the Council Directive:

Pressure Equipment Directive 97/23/EC: the abovementioned equipment has been designed and manufactured in accordance with the requirements of this Directive.

Max. operating Pressure: DN-25/1" to DN-150/6" = 10 bar

Diameter: DN-25 < ϕ = **X** < ϕ = DN-50

Equipment category: SEP = Sound Engineering Practice, determined according to Article 3 Section 3, first paragraph Annex II, Table 1

This material SHALL NOT carry CE marking.

Diameter: **X** = DN-65 - 80

Equipment category: Category I, determined according to Article 3, Section 1.1.a, first paragraph Annex II, Table 1

This material SHALL carry CE marking.

Conformity Assessment Module: Module A

Diameter: DN-100/125/150

These filters are subject to the following assessment procedure, **Module A, Category I, fluids Group 2.**

This material SHALL carry CE marking.

In compliance with **Regulation (EC) 1935/2004**, relating to materials and articles intended to come into contact with food (repealing Directive 89/109/EEC), the materials in contact with the product do not transfer their constituents to the product in quantities which could endanger human health.

Banyoles, 2014



DAVID REYERO
Technical manager

1. Safety

1.1. INSTRUCTION MANUAL

This instruction manual contains basic indications which should be fulfilled during the installation, start-up, and maintenance of this product.

The information published in the instruction manual is based on updated data.

INOXPA reserves the right to modify this instruction manual without prior notice.

1.2. COMMISSIONING INSTRUCTIONS

This instruction manual contains essential and useful information for the correct handling and maintenance of the filter.

The safety instructions detailed in this chapter as well as all the special measures and recommendations included in the other chapters of this manual must be observed and fulfilled. These instructions should be kept in a safe location near the installation area.

1.3. SAFETY

1.3.1. Warning symbols



Safety hazard for people in general



Danger! Caustic or corrosive agents.



Danger for the correct operation of the equipment



Mandatory to ensure safety at the workplace



Mandatory use of safety goggles

1.4. GENERAL SAFETY INSTRUCTIONS



Read the instruction manual carefully before installing and using the filter for the first time. Contact INOXPA in case of doubt.

1.4.1. During installation



The *Technical Specifications* in Chapter 8 should always be observed.

The installation and use of the filter must always be carried out in accordance with applicable health and safety regulations.

Before using the filter, verify that it is correctly assembled and that the clamp is securely closed.

1.4.2. During operation



The *Technical Specifications* in Chapter 8 should always be observed. Under no circumstances can the limit values specified be exceeded.



NEVER touch the filter and/or the lines that are in contact with the liquid during operation. A burn hazard exists when working with hot products.

1.4.3. During maintenance



The *Technical Specifications* in Chapter 8 should always be observed.

NEVER disassemble the filter until the pipes have been emptied. Bear in mind that the liquid in the line may be dangerous or extremely hot. Consult the regulations in effect in each country for these cases.

Do not leave loose parts on the floor.

1.4.4. Compliance with the instructions

Not following the instructions may impose a risk for the operators, the environment and the machine, and may result in the loss of the right to claim damages.

This non-compliance may impose the following risks:

- Failure of important machine/plant functions.
- Failure of specific maintenance and repair procedures.
- Possibility of creating electric, mechanical and chemical hazards.
- Would place the environment at risk due to the type of substances released.

1.5. WARRANTY

Any warranty will be void immediately and lawfully, and, in addition, we will request compensation for any claims of civil liability presented by third parties, in the following cases:

- The installation and maintenance work has not been carried out according to the instructions in this manual.
- The repairs are not carried out by our personnel or have been carried out without our written authorisation.
- The parts used are not INOXPA genuine parts.
- Modifications have been carried out on our material or equipment without written authorisation.
- The material or equipment has been improperly used, has been used negligently, or has not been used according to the instructions and their intended use as specified in this manual.

The general conditions of delivery that are already in your possession are also applicable.

Please do not hesitate to contact us in case of doubts or if further explanations are required regarding specific data (adjustments, assembly, disassembly, etc.).

2. Table of contents

1. Safety	
1.1. Instruction manual.....	3
1.2. COMMISSIONING INSTRUCTIONS.....	3
1.3. SAFETY.....	3
1.4. GENERAL SAFETY INSTRUCTIONS	3
1.5. WARRANTY	4
2. Table of contents	
2.1.....	5
3. Delivery and installation	
3.1. CHECKING THE SHIPMENT	6
3.2. ACCEPTANCE AND UNPACKING.....	6
3.3. IDENTIFICATION	7
3.4. PLACEMENT	7
3.5. INSTALLATION	8
3.6. FINAL CHECK	8
3.7. WELDING.....	8
4. Start-up	
4.1. START-UP	9
4.2. OPERATION	9
5. Operating problems: causes and solutions	
6. Maintenance	
6.1. GENERAL CONSIDERATIONS	11
6.2. Maintenance.....	11
6.3. Cleaning.....	12
7. Assembly and disassembly	
7.1. Filter disassembly / assembly	13
8. Technical Specifications	
8.1. Technical specifications	14
8.2. Filter dimensions.....	15
8.3. List of materials	15

3. Delivery and installation

3.1. CHECKING THE SHIPMENT

The first thing to do on receiving the filter is to check it and verify that it matches the delivery note. INOXPA will inspect all the equipment before packing, although it cannot guarantee that the merchandise will arrive intact to the user. For this reason, the valve received and any other article should be checked and, if it is found not to be in good condition and/or not all parts are included, the carrier should submit a report as soon as possible.

3.2. ACCEPTANCE AND UNPACKING



INOXPA will not be responsible for the inappropriate unpacking of the filter and its components.

3.2.1. Acceptance:

Check that all the parts indicated in the delivery slip are present.

- Complete filter
- Delivery note
- Instruction manual

3.2.2. Unpacking:

- Remove all traces of packing materials from the filter or its parts. The filters are always delivered assembled.
- Inspect the filter or its constituent parts for possible damage caused during transport.
- Avoid any possible damage to the filter and its components

3.3. IDENTIFICATION

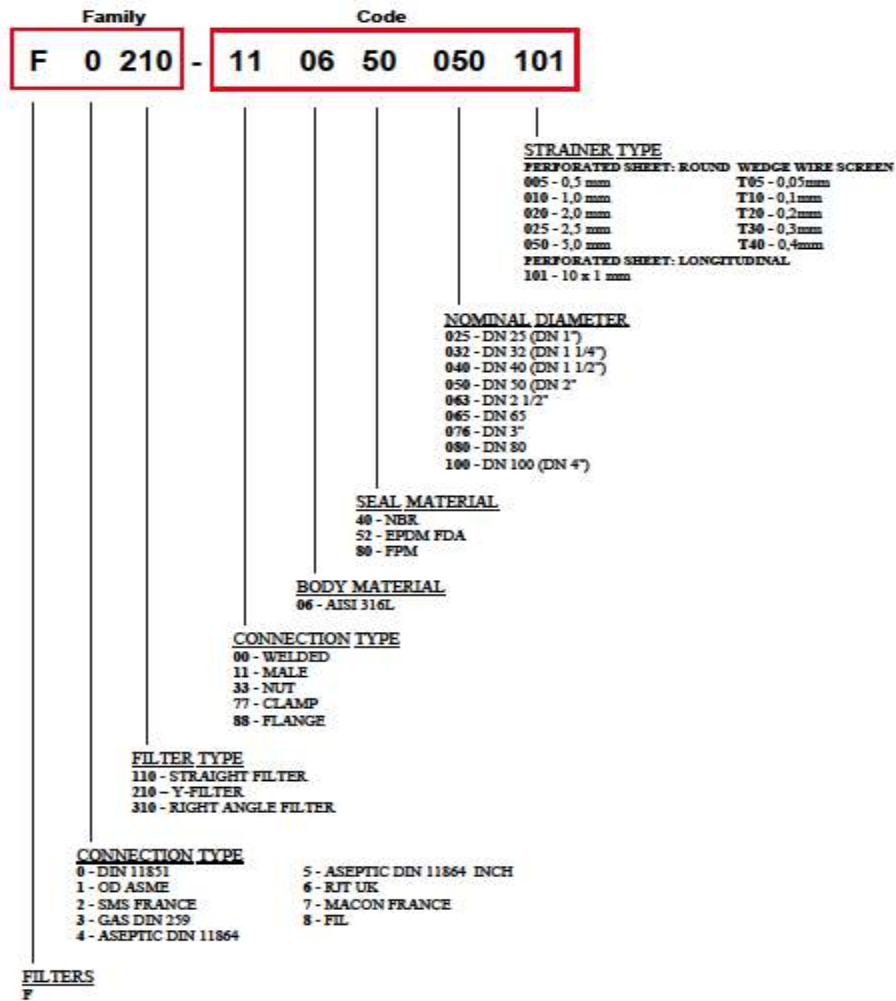

F0210-110650050101 – Y-filter in AISI-316L, connections M/M DIN DN-50, strainer screen with perforated sheet with 10x1 longitudinal holes and EPDM seals.

11.106.32.0002



The buyer or user will be responsible for the assembly, installation, commissioning and operation of the filter.

3.4. PLACEMENT

The filters are suitable for contact with food products.

Place the filter in such a way as to facilitate inspections and checks. Leave sufficient space around the filter for appropriate inspection, separation and maintenance. It is very important to ensure that enough space is available for removing the strainer screen.

3.5. INSTALLATION

Once the filter has been installed at the desired location it can be connected to the pipeline by welding the filter body or by means of accessories (connectors).

Excessive stress should be avoided during the installation of the filter and special attention should be given to the following:

- Vibrations which may be produced during the installation.
- The expansion of the lines during the circulation of hot liquids.
- The weight that the lines can withstand.
- Excessive welding current.

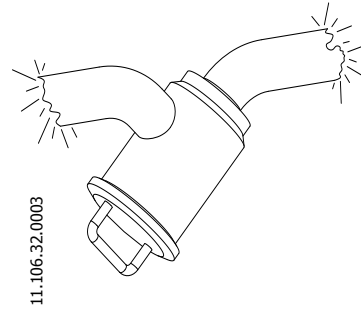

3.6. FINAL CHECK

Check the following before use:

- Check the flow direction of the product.

The drawing on the right shows the recommended installation position.

The solids are trapped inside the strainer screen and remain in its interior when it is removed.

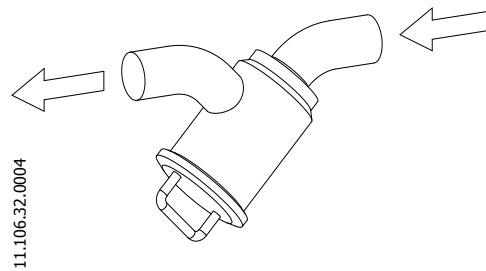

3.7. WELDING



Any welding work may only be carried out by qualified personnel that has been suitably trained and equipped with the necessary means to carry out this work. Disassemble the filter before starting the welding work.

3.7.1. Welding the filter

- Disassemble the filter as indicated in the [Disassembly](#) section.
- Weld the filter body to the pipework.

4. Start-up

The filter can be used provided the instructions indicated in Chapter 3. *Delivery and Installation* are followed.

4.1. START-UP



Before operating the filter, the persons responsible should be duly informed about the operation of the filter and the safety instructions to be followed. This instruction manual should be available to personnel at all times.

The following should be taken into consideration before using the filter:

- Check that the pipeline and the filter are completely free from any traces of welding or other foreign matter. Proceed to clean the system if required.
- Check for possible leaks and check that all the lines and connections are watertight and free from leaks.
- Open the circuit.

4.2. OPERATION



Do not modify the operating parameters for which the filter has been designed without prior written authorisation from INOXPA.



Burn Hazard! Do not touch the filter or pipes when hot liquids are circulating or when cleaning and/or sterilisation procedures are being carried out.

- The liquid enters the filter and the largest solid particles are trapped by the strainer screen inside the filter.
- The filtered liquid exits through the filter outlet.

Visually check that no leaks are present in the sealed area.

5. Operating problems: causes and solutions

PROBLEM	CAUSE / EFFECT	SOLUTION
EXTERNAL PRODUCT LEAK	The clamp seal is worn or deteriorated. The sealing clamp is not sufficiently tight.	<ul style="list-style-type: none"> • Replace the clamp seal. • Replace the seal material. • Tighten the sealing clamp.
NO PRODUCT IS FLOWING THROUGH THE PIPELINE	The strainer screen is blocked.	<ul style="list-style-type: none"> • Remove and clean the strainer screen.
	The pipe is blocked.	<ul style="list-style-type: none"> • Unblock the pipe.
EXCESSIVE SEDIMENTS PASS THROUGH THE FILTER	The strainer screen is defective or damaged.	<ul style="list-style-type: none"> • Replace the strainer screen.

6. Maintenance

6.1. GENERAL CONSIDERATIONS

This filter, just like any other machine, requires maintenance. The instructions contained in this manual cover the identification and replacement of spare parts. The instructions have been prepared for maintenance personnel and for those responsible for the supply of spare parts.



Carefully read Chapter 8. *Technical specifications.*

All replaced material should be duly eliminated/recycled according to the directives in effect in the area.

Assembly and disassembly of the filters must only be carried out by qualified staff.

6.2. MAINTENANCE

The following is recommended for correct maintenance:

- Regular inspection of the filter and its components
- Keep a record of the operation of each filter, noting any incidents
- Always have spare seals in stock

During maintenance, pay particular attention to the danger warnings indicated in this manual.



The filter and pipes should never be pressurised during maintenance.

The filter should never be hot during maintenance. Burn Hazard!

6.2.1. Maintenance of the seals

SEAL REPLACEMENT	
Preventive maintenance	Replace after twelve (12) months.
Maintenance after a leak	Replace at the end of the process.
Scheduled maintenance	Check for the absence of leaks on a regular basis. Keep a record of the filter. Use statistics to plan inspections.

The time interval between each preventive maintenance operation may vary according to the working conditions to which the filter is subjected: temperature, pressure, particle diameter, type of cleaning solutions used, etc.

6.2.2. Storage

The filters should be stored in a closed area, under the following conditions:

- Temperature 15°C to 30°C
- Air humidity <60%

Open-air storage of the equipment is **NOT** permitted.

6.2.3. Spare parts

To request spare parts, it is necessary to indicate the type of filter, the position and the description of the part which can be found in the Technical specifications section.

6.3. CLEANING



The use of aggressive cleaning products such as caustic soda and nitric acid may burn the skin.

Use rubber gloves during the cleaning process.



Always use protective goggles.

6.3.1. Cleaning

- Loosen and remove the sealing clamp, check the seal.
- Remove the filter by pulling from its handle, check the internal O-ring seal.
- Clean the filter outside of its housing, do not allow any particles or deposits adhering to the strainer screen to dry out because its subsequent cleaning would be very difficult. See chapter 7.1 *Filter disassembly / assembly*.
- Insert the assembly into its housing.

6.3.2. CIP (Clean-in-Place) cleaning

Cleaning solutions for CIP processes.

Only use clear water (chlorine-free) to mix with the cleaning agents:

a) Alkaline solution: 1% by weight of caustic soda (NaOH) at 70°C (150°F)

1 kg NaOH + 100 litres of water = cleaning solution
or
2.2 litres of 33% NaOH + 100 litres of water = cleaning solution

b) Acid solution: 0.5% by weight of nitric acid (HNO₃) at 70°C (150°F)

0.7 litres of 53% HNO₃ + 100 litres of water = cleaning solution



Check the concentration of the cleaning solutions; incorrect concentrations may lead to the deterioration of the filter seals.

To remove any remains of cleaning products, ALWAYS perform a final rinse with clean water upon completion of the cleaning process.



Before beginning with the disassembly and assembly tasks, clean both the interior and exterior of the filter.

6.3.3. Automatic SIP (Sterilization-in-Place)

Sterilization with steam is applied to all equipment including pigging.



No cold liquid can enter the equipment until the temperature of the equipment is lower than 60°C (140°F).

Maximum conditions during the SIP process with steam or overheated water

- a) **Max. temperature:** 140°C / 284°F
- b) **Max. time:** 30 min.
- c) **Cooling:** Sterile air or inert gas
- d) **Materials:** EPDM / FPM / NBR

7. Assembly and disassembly



Assembly and disassembly of the filter must only be carried out by qualified staff.

7.1. FILTER DISASSEMBLY / ASSEMBLY

Disassembly

1. Depressurise and drain the pipelines in the circuit.
2. Remove the clamp (34) from the filter.
3. Pull out the strainer assembly (29) from the filter body (01).
4. Remove and check the clamp seal (61) and the O-ring seal (20).

Assembly

1. Place the O-ring (20) on the strainer screen (29) and the clamp seal (61) on the filter body (01).
2. Insert the assembly in the body (01)
3. Tighten the sealing clamp (34) joining the strainer screen (29) and the body (01).

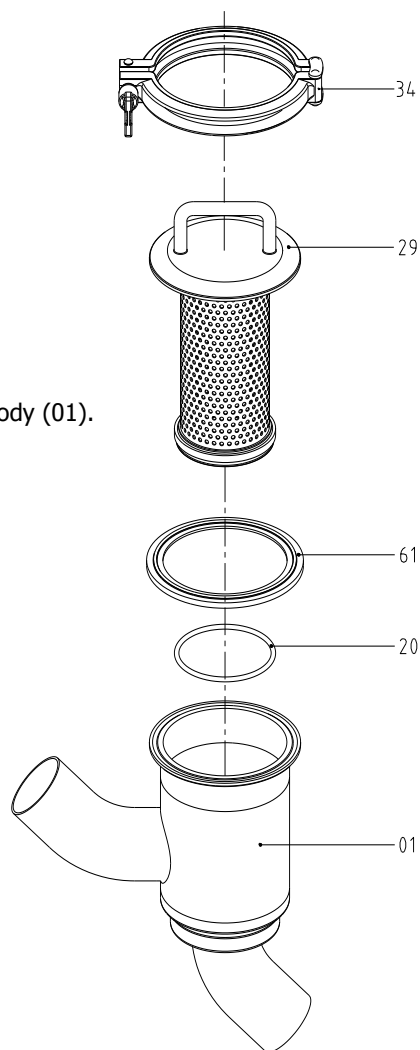

8. Technical Specifications

8.1. TECHNICAL SPECIFICATIONS

FILTER GENERAL DATA	
Maximum working pressure	10 bar
Maximum working temperature	121°C (250 °F) Standard EPDM seals (other seal materials supplied for higher temperatures)
Surface finish	Internal surface finish: $Ra \leq 0.8 \mu m$ External surface finish: mirror polished

FILTER MATERIAL	
Parts in contact with the product	AISI 316L (1.4404)
Other steel parts	AISI 304 (1.4301)
Seals in contact with the product	EPDM (Standard) - NBR - FPM
Type of connections	Welding (standard) DIN 11851, FIL-IDF, BS-RJT, SMS, clamps, flanges, Macon.

STRAINER SCREEN: WEDGE WIRE		
Eq.mesh C	(mm)	Useful surf. (%)
40	0.40	28
60	0.30	23
80	0.20	17
165	0.10	10
325	0.05	5

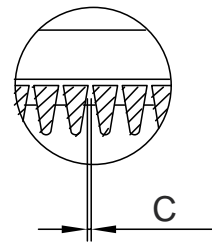

STRAINER SCREEN: PERFORATED PLATE	
A (mm)	Useful surf. (%)
0.5	15
1	28
2	30
5	46
10x1	20

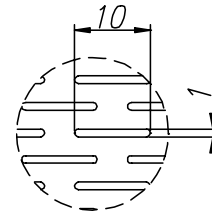
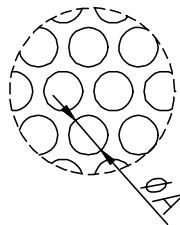

8.2. FILTER DIMENSIONS

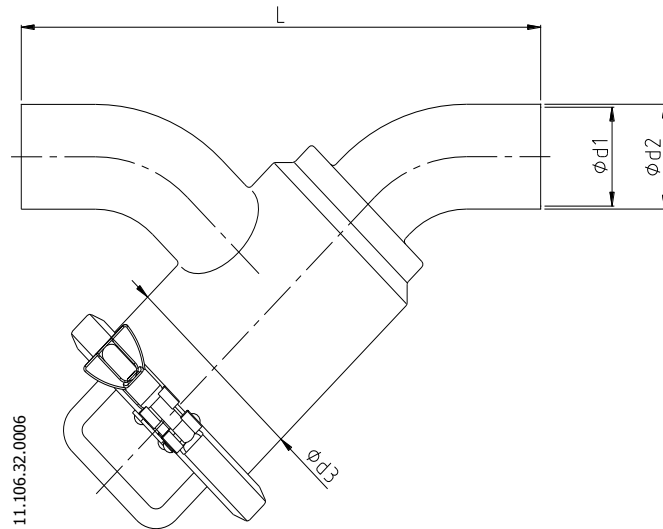

WELDING / DIN WELDING				
DN	d1	d2	d3	L
25	26	29	76.2	235
32	32	35		240
40	38	41	101.6	260
50	50	53		280
65	66	70	114.3	320
80	81	85		375
100	100	104	154	400
125	125	129	219.1	665
150	150	154		719

WELDING / OD WELDING				
DN	d1	d2	d3	L
1"	22.1	25.4	76.2	213
1 1/2"	34.8	38.1	101.6	242
2"	47.5	50.8		300
2 1/2"	60.2	63.5	114.3	348
3"	72.9	76.2		378
4"	97.4	101.6	154	468
6"	146.8	152.4	219.1	652.7

8.3. LIST OF MATERIALS

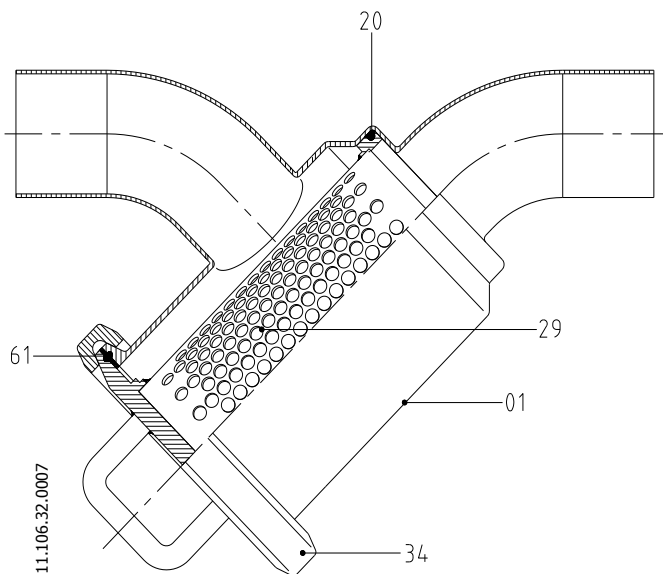

Position	Description	Material	Quantity
01	Body	AISI 316L	1
20*	O-ring seal	EPDM	1
29	Strainer screen	AISI 316L	1
34	Sealing clamp	AISI 316L	1
61*	Clamp seal	EPDM	1

*Recommended spare parts.

Арматура — Фильтры 81700 82700 83700

<http://k-tep.com.ua/>

✉ k-tep@ukr.net

■ Office +38 044 2091823

■ МТС +38 066 9076563

■ Киевстар +38 098 6909428

Skype: [k-teppumps](#)

Замечания

Условия поставки: DDP склад г. Киев

Заметки

Время поставки рассчитано согласно дате предложения и изменяется в зависимости от даты подтверждения заказа.

Размещая заказ, покупатель принимает предложение и все спецификации, характеристики и условия, указанные в данном документе.