

REVISION HISTORY

REV	DESCRIPTION	DATE	APPROVED

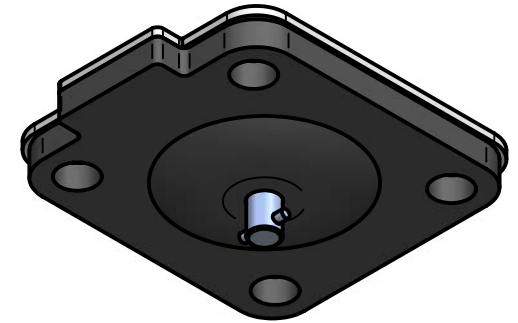
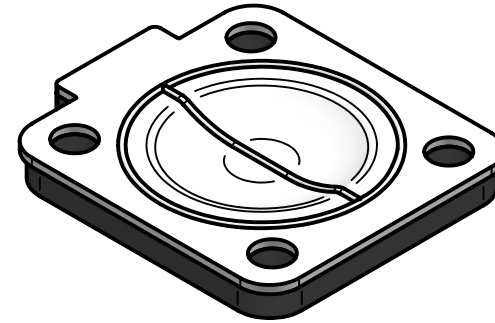

Replacement Diaphragm for :-
 OEM PART = 0.500-P2
 USED ON 1/2" (DN15,) Diaphragm Valve

	NAME	DATE
DRAWN	M. MC KEON	08/21/14
CHECKED		



Material -
EPDM BACKING
TFM - DIAPHRAGM

TITLE
DD05-STFM

Complies with CFR 177.2600
 and Conforms to
 USP Class VI Biological Reactivity
 Tests Section #87 and #88

SIZE A	FOOT PRINT DIMENSIONS	REV B
-----------	------------------------------	----------

SCALE: 1 : 1	ECC:0605	SHEET 1 OF 1
--------------	----------	--------------

Disclaimer - Diaphragm Direct® does not manufacture, represent, nor sell OEM valves or diaphragms manufactured by any other company. Diaphragm Direct® brand diaphragms are not sponsored by any other manufacturers. Any name, model, part number, brand, image, material or referral is for descriptive purposes only. Diaphragm Direct® brand replacement diaphragms are guaranteed to fit OEM equipment and meet or exceed OEM specifications. Diaphragm Direct® brand replacement diaphragms are covered by the standard Diaphragm Direct® limited product warranty.