

**ИНСТРУКЦИЯ ПО УСТАНОВКЕ И  
ТЕХНИЧЕСКОМУ ОБСЛУЖИВАНИЮ  
ОДНОСЕДЕЛЬНЫЙ КЛАПАН NLS**

**INSTALLATION, SERVICE AND MAINTENANCE  
INSTRUCTIONS  
SINGLE-SEAT RELIEF VALVE NLS**



**INOXPA, S.A.**  
c/Telers, 54 Aptdo. 174  
E-17820 Banyoles  
Girona (Spain)



Original Manual  
10.210.30.05EN  
ED. 2011/03

## Declaration of Incorporation

The manufacturer:

c/ Telers, 57  
17820 Banyoles (Girona), Span

herewith declares that the machine:

### **NLS Valve single-seat relief**

with the serial number: \_\_\_\_\_

conforms to the relevant provisions of the following directives:

Machinery Directive 2006/42/EC (RD 1644/2008)  
Pressure equipment Directive 97/23/EC

It also declares that the technical documentation for this partly completed machinery has been developed in compliance with Appendix VII Section B and it agrees to issue this documentation as and when required by the national authorities.

In compliance with Regulation (EC) 1935/2004 on materials and articles intended to come into contact with food.

In compliance with Regulation (EC) 2023/2006 on good manufacturing practice for materials and articles intended to come into contact with food.

The aforementioned partly completed machinery shall NOT be put into service until the final machinery into which it is to be incorporated has been declared in conformity with the Machinery Directive, as required by Appendix II A.

Identification of the person empowered to draw up the Declaration on behalf of the manufacturer, and qualified to compile the technical file established by the Community:

Banyoles, 8 January 2014



David Reyer Brunet  
Technical Office Manager

# 1. Safety

## 1.1. INSTRUCTION MANUAL

This instruction manual contains basic indications which should be fulfilled during the installation, start-up, and maintenance of this product.

The information published in the instruction manual is based on updated information.

INOXPA reserves the right to modify this instruction manual without prior notice.

## 1.2. INSTRUCTIONS FOR START-UP

This instruction manual contains essential and useful information for the correct handling and maintenance of the valve.

The safety instructions detailed in this chapter as well as all the special measures and recommendations included in the other chapters of this manual must be observed and fulfilled. These instructions should be kept in a safe location near the installation area.

## 1.3. SAFETY

### 1.3.1. Warning symbols



Danger for persons in general



Danger of injury caused by moving equipment parts



Electric danger



Danger! Caustic or corrosive agents



Danger! Suspended loads



Danger for the correct operation of the equipment



Commitment to safety at the workplace



Protective goggles requirement

## 1.4. GENERAL SAFETY INSTRUCTIONS



Read the instruction manual carefully before installing and starting up the valve.

### 1.4.1. During installation



The *Technical Specifications* of Chapter 8 should always be observed.

The installation and use of the valve must always be carried out in accordance with applicable health and safety regulations.

Before starting up the valve, verify that it is correctly assembled and that the shaft is perfectly aligned. An incorrect alignment and/or excessive force in securing the valve may cause serious mechanical problems in the valve.

### 1.4.2. During operation



The *Technical Specifications* of Chapter 8 should always be observed. Under no circumstances can the limit values specified be exceeded.



**NEVER** touch the valve and/or pipes in contact with the liquid during operation; there is a risk of burns when working with hot products.



**The valve contains parts with linear movement. Never put the hands or fingers on the closing area of the valve. This can cause serious injuries.**

#### 1.4.3. During maintenance



The *Technical Specifications* of Chapter 8 should always be observed.

**NEVER disassemble the valve until the pipes have been emptied. Bear in mind that the liquid in the pipe may be dangerous or extremely hot. Consult the regulations in effect in each country for these cases.**

**Do not leave loose parts on the floor.**



**All the electric work should be carried out by authorised personnel.**

#### 1.4.4. Compliance with the instructions

Any nonfulfilment of the instructions may result in a risk for the operators, the environment and the machine, and may result in the loss of the rights to claim damages.

This nonfulfilment may result in the following risks:

- Failure of important functions of the machines/plant.
- Failure in specific maintenance and repair procedures.
- Possibility of electric, mechanical and chemical risks.
- Will place the environment in danger due to the type of substances released.

#### 1.5. WARRANTY

Any warranty will be void immediately and lawfully, and, in addition, we will request compensation for any claims of civil liability presented by third parties, in the following cases:

- The installation and maintenance work has not been carried out according to the instructions in this manual.
- The repairs are not carried out by our personnel or have been carried out without our written authorisation.
- The parts used are not INOXPA genuine parts.
- Modifications have been carried out on our material or equipment without written authorisation.
- The material or equipment has been badly used, incorrectly used, or used with negligence or has not been used according to the indications and intended use specified in this manual.

The general conditions of delivery already in your possession are also applicable.

Please do not hesitate to contact us in case of doubts or more complete explanations are required on specific data (adjustments, assembly, disassembly, etc.).

---

# 2. Table of contents

<b>1. SAFETY</b>	
1.1. INSTRUCTION MANUAL .....	3
1.2. INSTRUCTIONS FOR START-UP.....	3
1.3. SAFETY .....	3
1.4. GENERAL SAFETY INSTRUCTIONS .....	3
1.5. WARRANTY .....	4
<b>2. TABLE OF CONTENTS</b>	
<b>3. ACCEPTANCE AND INSTALLATION</b>	
3.1. CHECKING THE SHIPMENT.....	6
3.2. ACCEPTANCE AND UNPACKING.....	6
3.3. PLACEMENT .....	6
3.4. FLOW DIRECTION.....	6
3.5. ASSEMBLY .....	7
3.6. INSPECTIONS AND CHECKS.....	7
3.7. WELDING.....	7
3.8. AIR CONNECTION TO THE ACTUATOR .....	8
<b>4. START-UP</b>	
4.1. SINGLE-SEAT VALVE APPLICATIONS .....	9
4.2. START-UP.....	9
4.3. OPERATION.....	9
4.4. VALVE SETTING .....	9
<b>5. OPERATING PROBLEMS: CAUSES AND SOLUTIONS</b>	
<b>6. MAINTENANCE</b>	
6.1. GENERAL INFORMATION.....	11
6.2. MAINTENANCE .....	11
6.3. CLEANING .....	12
<b>7. ASSEMBLY AND DISASSEMBLY</b>	
7.1. DISASSEMBLY / ASSEMBLY OF THE NLS SINGLE-SEAT RELIEF VALVE .....	13
<b>8. TECHNICAL SPECIFICATIONS</b>	
8.1. DIMENSIONS .....	15
8.2. EXPLODED VIEW AND PARTS LIST.....	16

# 3. Acceptance and Installation

## 3.1. CHECKING THE SHIPMENT

The first thing to do on receiving the valve is to verify that it matches the delivery note.

INOXPA will inspect all the equipment before packing, although it cannot guarantee that the merchandise will arrive intact to the user. For this reason, the valve and any other article received should be checked and, if it is found not to be in good condition and/or not all parts are included, the carrier should submit a report as soon as possible.

Each valve has a manufacturing number engraved. Indicate the manufacturing number in all documents and correspondence.

C. TELERS 54 . 17820 BANYOLES GIRONA (SPAIN) . www.inoxpa.com		CE	PGF AIO64
FIGURE NF:		SIZE:	
DESCRIPTIO:			
WORKING PRESSURE: Min.		Max.	
serial number → MANUFACTURING NR.		MODEL	

10.2110.32.0012

## 3.2. ACCEPTANCE AND UNPACKING



**INOXPA will not be responsible for the inappropriate unpacking of the valve and its components.**

### 3.2.1. Acceptance:

Check that all the parts indicated in the delivery slip are present

- Complete valve
- Its components (if supplied)
- Delivery note
- Instruction manual

### 3.2.2. Unpacking:

- Remove all traces of packing materials from the valve or its parts
- Inspect the valve or its constituent parts for possible damage caused during transport
- Avoid any possible damage to the valve and its components



**The buyer or user will be responsible for the assembly, installation, starting and operation of the valve.**

## 3.3. PLACEMENT

Place the valve in such a way as to facilitate inspections and checks. Leave sufficient space around the valve for appropriate inspection, separation and maintenance (See Section 3.8.1)

## 3.4. FLOW DIRECTION

The flow direction for the product passing through each of the valve types is indicated below. Following these indications will help to prevent as much as possible any pipe hammering and the consequences of this caused during single-seat valve closing operations. The flow direction is always contrary to the valve closing movement, that is to say, the plug shaft always works against the fluid pressure when closing the valve.

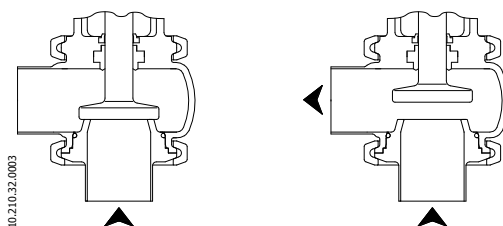

### 3.5. ASSEMBLY

Once the valve has been installed at the desired location it can be connected to the pipeline by welding the valve body or by means of accessories (connectors). In the latter case, do not forget to install the appropriate seals and to tighten the joints well.

Before welding the valve body to the pipework, disassemble the valve to prevent damage to the seals.

Excessive stress should be avoided during the assembly of the valves and special attention should be given to the following:

- vibration which may be produced during installation
- expansion of the pipes during circulation of hot liquids
- the weight that the pipes can withstand
- excessive intensity of welding

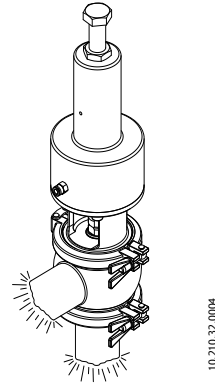

10.210.32.0004

### 3.6. INSPECTIONS AND CHECKS

Check the following before use:

- Check that the clamps and the nuts are well tightened.
- Open and close the valve (applying compressed air to the actuator) several times to ensure that it operates correctly and check that the shaft seal fits smoothly against the valve body.

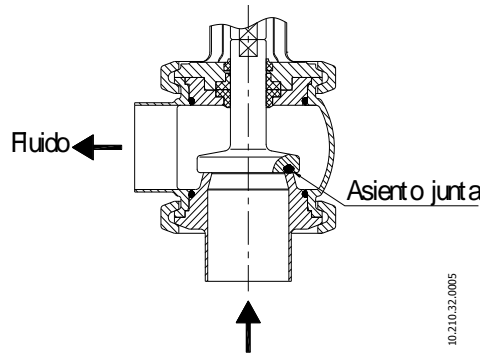

10.210.32.0005

### 3.7. WELDING



**Any welding work may only be carried out by qualified personnel that has been suitably trained and equipped with the necessary means to carry out this work.**

**Disassemble the valve before starting the welding work.**

#### 3.7.1. Welding single-seat valve

- Disassemble the valve as indicated in section 7. *Assembly and disassembly*
- Weld the valve body to the pipework.
- When welding the valve body, it is very important to maintain the minimum distance (dimension A) which will allow the later disassembly of the valve for checks and replacement of valve parts (e.g. seals, springs, etc.), if required.

DN	A
25-1"	350
40-1 1/2"	360
50-2"	430
65 - 2 1/2"	450
80 - 3"	460

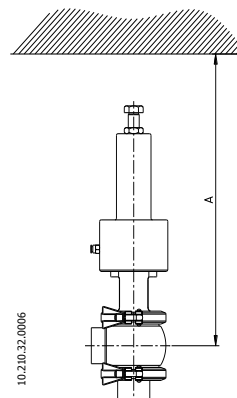

10.210.32.0006

---

### 3.8. AIR CONNECTION TO THE ACTUATOR

- Connect the air line and check the connections.
- INOXPA valves are supplied with connections for Ø6 pipe.
- Ensure that the quality of the compressed air is in accordance with the specifications described in Chapter 8 *Technical Specifications*.

Pneumatic connections  
Thread R 1/8" (BSP)

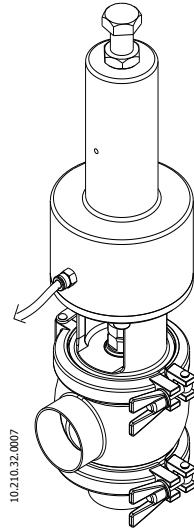



# 4. Start-up

The valve is ready for operation provided the instructions indicated in Chapter 3 – *Receiving and Installation* have been followed.

## 4.1. SINGLE-SEAT VALVE APPLICATIONS

The NLS valve is a pneumatically actuated single-seat valve designed for use as relief valve. The closing pressure of the valve is set by the spring pressure, which can be regulated by means of the screw located on the top of the valve. When the set pressure is exceeded, the valve opens. The valve is supplied with a pneumatic seat lift that allows the CIP liquid to pass through during CIP cleaning.

## 4.2. START-UP



**Before operating the valve, the persons responsible should be duly informed about the operation of the valve and the safety instructions to be followed. This instruction manual should be available to personnel at all times.**

The following should be taken into consideration before starting up the valve/actuator:

- Check that the pipe and valve are completely free from any traces of welding or other foreign matter. Carry out the cleaning of the system if required.
- Verify the smooth operation of the valve. If necessary, lubricate with special grease or soapy water.
- Check for possible leaks and check that all the pipes and connections are watertight and free from leaks.
- Make sure that the alignment of the valve shaft with the actuator shaft allows for a smooth operation.
- Check that the compressed air pressure at the intake to the actuator is that indicated in the *Technical Specifications* in Chapter 8.
- Ensure that the quality of the compressed air is in accordance with the specifications described in Chapter 8 Technical Specifications.
- Operate the valve.

## 4.3. OPERATION



**Do not modify the operating parameters for which the valve has been designed without written prior authorisation from INOXPA.**

**Do not touch the moving parts of the coupling between the actuator and the valve when the actuator is connected to the compressed air supply.**



**Danger of burns! Do not touch the valve or pipes when hot liquids are circulating or when cleaning and/or sterilisation are being carried out.**

## 4.4. VALVE SETTING

The NLS valve can be set by the client. Calibration requires a pump, a pressure gauge (to measure the pressure), a shut-off valve and an NLS valve.

Start up the pump with the shut-off valve in the closed position. The liquid will pass through the NLS valve, which will act as a bypass (recirculation). Tighten the top screw (previously loosening the lock nut) on the NLS valve until the pressure gauge indicates the pump's maximum working pressure. The valve will then be set to the pressure indicated on the pressure gauge; if this pressure is exceeded, the valve will close and the flow will be recirculated, thus preventing any damage to the system.

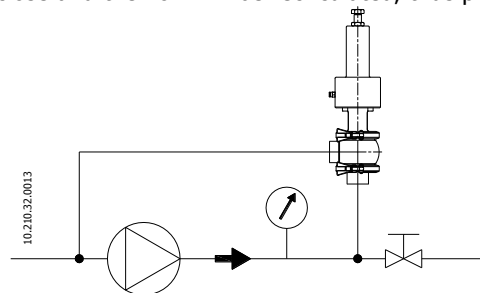

# 5. Operating problems: causes and solutions

PROBLEM	CAUSE / EFFECT		SOLUTION
JERKING OF THE VALVE PLUG	The seal or bushing are worn out, deteriorated, or blocked.		<ul style="list-style-type: none"> <li>• Replace the seals</li> <li>• Replace the seals with others of different material and better suited for the product</li> <li>• Lubricate with soapy water or lubricant compatible with the material of the seal and with the product</li> </ul>
	Insufficient air pressure		<ul style="list-style-type: none"> <li>• Replace the actuator with a larger one</li> <li>• Increase the compressed air pressure</li> </ul>
INTERNAL PRODUCT LEAK (CLOSED VALVE)	Normal wear of the seals		<ul style="list-style-type: none"> <li>• Replace the seals</li> </ul>
	Premature wearing of the seals	Watertight seal worn or affected by the product Excessive pressure in the line Excessive operating temperature System not tight	<ul style="list-style-type: none"> <li>• Replace the seals with others of different material and better suited for the product</li> <li>• Tighten any loose components</li> <li>• Clean frequently</li> </ul>
VALVE DOES NOT OPEN/CLOSE	Deformation of seals Actuator spring in bad condition and/or jammed (dirt) Excessive pressure on the valve plug		<ul style="list-style-type: none"> <li>• Replace the seals with others of different quality, if prematurely deteriorated</li> <li>• Replace spring (clean)</li> <li>• Reduce pressure</li> </ul>

# 6. Maintenance

## 6.1. GENERAL INFORMATION

This valve, just like any other machine, requires maintenance. The instructions contained in this manual cover the identification and replacement of spare parts. The instructions have been prepared for maintenance personnel and for those responsible for the supply of spare parts.



Carefully read Chapter 8. *Technical specifications*.

**All replaced material should be duly eliminated/recycled according to the directives in effect in the area.**

**Assembly and disassembly of the valves must only be carried out by qualified staff.**

**Before starting any maintenance work, ensure that the lines are not pressurised.**

## 6.2. MAINTENANCE

The following is recommended for correct maintenance:

- Regular inspection of the valve and its components
- Keep a record of the operation of each valve, noting any incidents
- Always have spare seals in stock

During maintenance, pay particular attention to the danger warnings indicated in this manual.



**The valve and lines should never be pressurised during maintenance.**

**The valve should never be hot during maintenance. Danger of burns!**

### 6.2.1. Maintenance of the seals

SEAL REPLACEMENT	
Preventive maintenance	Replace after twelve (12) months
Maintenance after a leak	Replace at the end of the process
Scheduled maintenance	Regularly check that there are no leaks and that the valve is operating smoothly. Keep a record of the valve. Use statistics to plan inspections.
Lubrication	During assembly, apply lubricants compatible with the seal material. See the following table.

SEAL MATERIAL	LUBRICANT	NLGI DIN 51818 Class
NBR/ FPM	Klübersynth UH 1 64-2403	3
EPDM/ NBR/ FPM	PARALIQ GTE 703	3

The time interval between each preventive maintenance operation may vary according to the working conditions to which the valve is subjected: Temperature, pressure, number of actuations per day, type of cleaning solutions used, etc.

### 6.2.2. Storage

The valves should be stored in a closed area, under the following conditions:

Temperature           15°C to 30°C  
Air humidity           <60%

Open-air storage of the equipment is **NOT** permitted.

### 6.2.3. Spare parts

To request spare parts, it is necessary to indicate the type of valve, the mounting location and the description of the part which can be found in the Chapter *Technical specifications*.

## 6.3. CLEANING



**The use of aggressive cleaning products such as caustic soda and nitric acid may cause burns to the skin.**

**Use rubber gloves during the cleaning process.**



**Always use protective goggles.**

### 6.3.1. CIP cleaning (Clean-in-Place)

If the valve is installed in a system with a CIP process, its disassembly will not be required.

Cleaning solutions for CIP processes.

Only use clear water (chlorine-free) to mix with the cleaning agents:

**a) Alkaline solution:** 1% by weight of caustic soda (NaOH) at 70°C (150°F)

1 kg NaOH + 100 litres of water = cleaning solution

or

2.2 litres of 33% NaOH + 100 litres of water = cleaning solution

**b) Acid solution:** 0.5% by weight of nitric acid (HNO<sub>3</sub>) at 70°C (150°F)

0.7 litres of 53% HNO<sub>3</sub> + 100 litres of water = cleaning solution



**Check the concentration of the cleaning solutions; incorrect concentrations may lead to the deterioration of the valve seals.**

To remove any remains of cleaning products, ALWAYS perform a final rinse with clean water on completion of the cleaning process.



**Before beginning with the disassembly and assembly tasks, clean both the interior and exterior of the valve.**

### 6.3.2. Automatic SIP (Sterilization-in-Place)

Sterilization with steam is applied to all equipment including pigging.



**Do NOT start the equipment during the sterilization with steam.**

**The parts/materials will suffer no damage if the indications specified in this manual are observed.**

**No cold liquid can enter the equipment until the temperature of the equipment is lower than 60°C (140°F).**

Maximum conditions during the SIP process with steam or overheated water

- a) Max. temperature:** 140°C / 284°F
- b) Max. time:** 30 min
- c) Cooling:** Sterile air or inert gas
- d) Materials:** EPDM / PTFE (recommended)  
FPM / NBR / VMQ (not recommended)

# 7. Assembly and disassembly



Proceed with caution. There is danger of personal injury.

Always disconnect the compressed air before starting valve disassembly.



Never disassemble the valve clamps directly without reading the instructions thoroughly.

Assembly and disassembly of the valves / actuator must only be carried out by qualified staff.

## 7.1. DISASSEMBLY / ASSEMBLY OF THE NLS SINGLE-SEAT RELIEF VALVE

### Disassembly

1. Loosen the nut (26) and unscrew the screw (22); apply compressed air to the actuator (10) in order to set the plug stem (08) in the open position.
2. Remove the lower clamp (34) and separate the bottom port (02) and corresponding seal (20B).
3. Release the compressed air from the actuator.
4. Remove the upper clamp (34) and separate the actuator (10A), lantern (21), shaft (08), and body cap (12) assembly from the valve body (01A).
5. Disassemble the plug shaft (08) from the actuator shaft and remove the seat seal (20).
6. Disassemble the body cap (12) and the corresponding seals (20B and 05).
7. Remove the guide bushing (11).
8. Unscrew the Allen screws (23) on the lantern (21) and remove the scraper (60).

### Assembly

9. Place the scraper (60) and guide bushing (11) in the lantern (21).
10. Place the lantern (21) underneath the actuator and screw in the four Allen screws (23).
11. Lubricate the gaskets with soapy water if necessary.
12. Fit the gaskets (20B and 05) on the body cap (12) and place this assembly on the lantern (21).
13. Join the plug shaft (08) with the actuator (10).
14. Apply compressed air to the actuator in order to set the plug shaft (08) in the open position.
15. Mount the actuator (10A), lantern (21), shaft (08), and body cap (12) assembly on the valve body (01A) (can be rotated 360° according to users' requirements), and secure it using the upper clamp (34).
16. Install the bottom port (02) with the corresponding seal (20B) and secure it with the lower clamp (34).
17. Release the compressed air from the actuator.
18. Set the screw (22) and lock the nut (26).

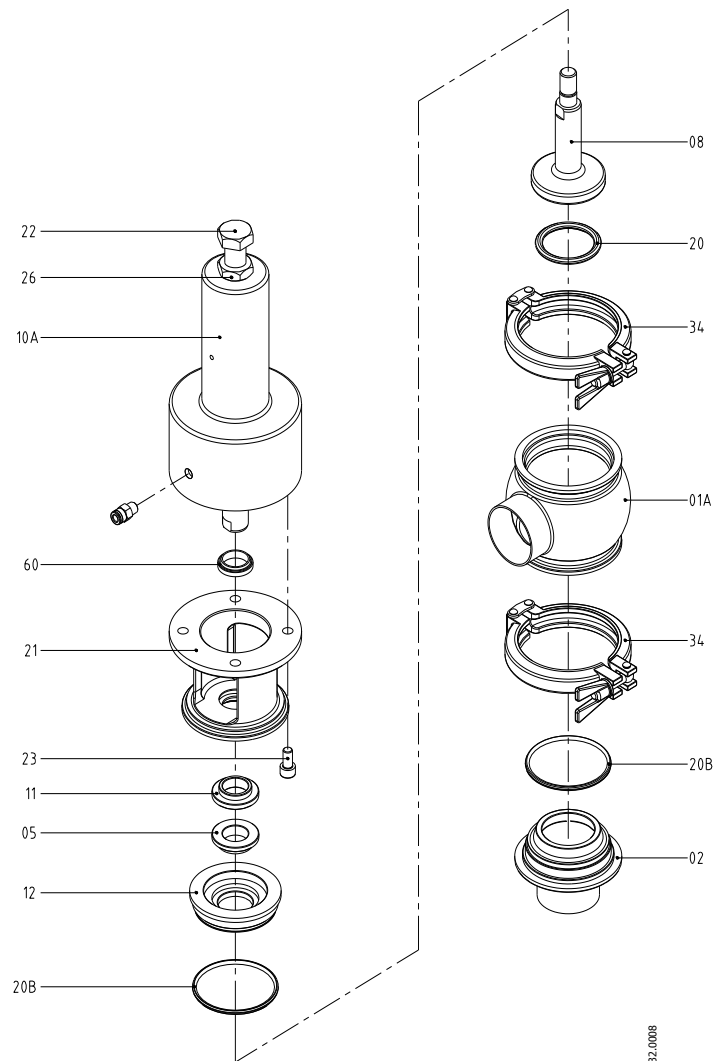

10.210.32.0008



The following tools are required to disassemble the valve:

- 5mm (DN-25/40) and 6mm (DN-50/80) Allen keys.
- Two 19 mm open end spanners

## 8. Technical specifications

GENERAL DATA VALVE		
Maximum working pressure	10 bar	
Maximum opening pressure	6 bar	
Minimum working pressure	Vacuum	
Maximum working temperature	121°C (250 °F) Standard EPDM seals (other seal materials supplied for higher temperatures)	
Compressed air pressure	6-8 bar	
Compressed air quality	In accordance with DIN/ISO 8573.1 <ul style="list-style-type: none"> <li>○ <u>Solid particle content</u>: Class 3 quality / Particle size max. 5 micron / Particle density max. 5 mg/m<sup>3</sup></li> <li>○ <u>Water content</u>: Class 4 quality / max. dew point +2°C. If the valve is used at higher altitudes or at low ambient temperatures, the dew point must be adapted accordingly</li> <li>○ <u>Oil content</u>: Class 5 quality, preferably oil-free / max. 25 mg oil in 1 m<sup>3</sup> air</li> </ul>	
Compressed air connection	R1/8" (BSP)	
Compressed air consumption	DN	Litres / cycle
	25	0.07
	40	0.07
	50	0.18
	65	0.31
	80	0.31

VALVE MATERIALS	
Parts in contact with the product	AISI 316L (1.4404)
Other steel parts	AISI 304 (1.4301)
Seals in contact with the product	EPDM (Standard) - NBR - VITON
Surface finish	In contact with the product: Ra ≤ 0.8 µm Exterior surfaces: machined finish (turned on lathe)
Type of connections	DIN 11851 (standard) Welding, FIL-IDF, BS-RJT, SMS, clamp, flanges, Macon.

## 8.1. DIMENSIONS

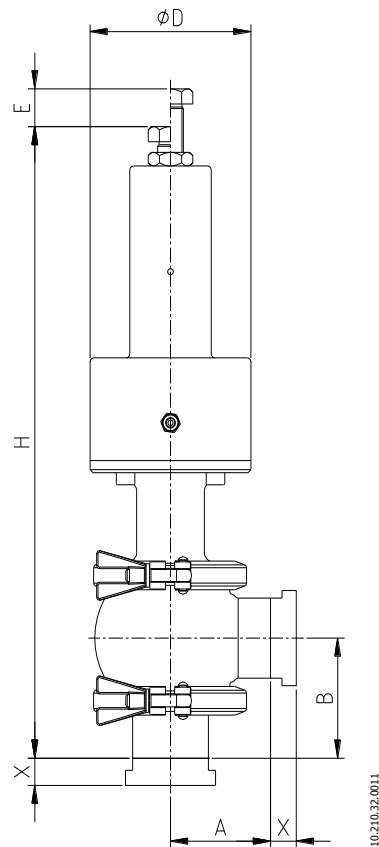

DN	A	B	ØD	E	H	X		
						Male DIN	Nut DIN	Clamp DIN
25	50	55	86	35	325	22	15	21,5
40	60	65	86	35	345	22	15	
50	70	80	112	25	405	23	16	
65	80	90	145	35	415	25	17	28
80	90	100	145	35	455	25	17	

DN	A	B	ØD	E	H	X		
						Male SMS	Nut SMS	Clamp OD
1"	50	55	86	35	325	19	15	13
1 1/2"	60	65	86	35	345	23	20	
2"	70	80	112	25	405	23	20	
2 1/2"	80	90	145	35	415	27	24	
3"	90	100	145	35	455	27	24	

## 8.2. EXPLODED VIEW AND PARTS LIST

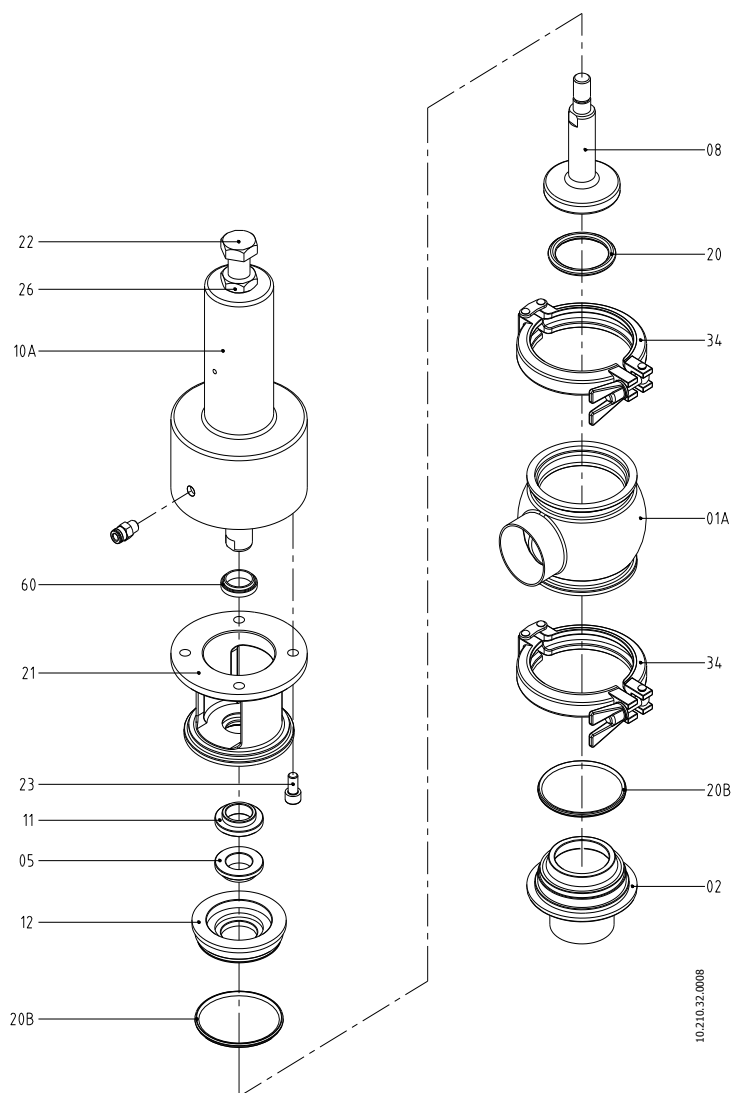

ITEM	DESIGNATION	MATERIAL	QUANTITY
01A	Interchangeable body L	AISI 316L	1
02	Lower port	AISI 316L	1
05	Shaft seal	EPDM	1
08	Shaft	AISI 316L	1
10A	Multi-way actuator NLS	AISI 304L	1
11	Guide bushing	PTFE	1
12	Body cap	AISI 316L	1
20	O-ring	EPDM	1
20B	O-ring	EPDM	2
21	Lantern	AISI 304L	1
22	Screw	AISI 304L	1
23	Allen screw DIN 912	A2	4
26	Nut	AISI 304L	1
34	Clamp	AISI 304L	2
60	Scraper	NBR	1



---

## Клапаны пищевые — Фармацевтический перепускной седельный клапан

<http://k-tep.com.ua/>

✉ [k-tep@ukr.net](mailto:k-tep@ukr.net)

■ Office +38 044 2091823

■ МТС +38 066 9076563

■ Киевстар +38 098 3676414

Skype: [k-teppumps](#)

### Замечания

*Условия поставки: DDP склад г. Киев*

#### Заметки

Время поставки рассчитано согласно дате предложения и изменяется в зависимости от даты подтверждения заказа.

Размещая заказ, покупатель принимает предложение и все спецификации, характеристики и условия, указанные в данном документе.