

**ИНСТРУКЦИЯ ПО УСТАНОВКЕ И  
ТЕХНИЧЕСКОМУ ОБСЛУЖИВАНИЮ**

**PFARMAVALVE**

**INSTALLATION, SERVICE AND MAINTENANCE  
INSTRUCTIONS**

**PFARMAVALVE**



c/Telers, 54 Aptdo. 174  
E-17820 Banyoles  
Girona (Spain)



ORIGINAL MANUAL'S TRANSLATION

10.320.30.01EN  
ED. 2009/09



## EC DECLARATION OF CONFORMITY

(In accordance with Directive 98/37/EC, annex II, part A)

We, the manufacturer:

c/ Telers, 54  
17820 Banyoles (Girona) - SPAIN

Hereby declare that the products

VALVE	PHARMAVALVE	2009
Name	Type	Year of Manufacture

conform with the provisions of the Council Directives:

**Machine Directive 98/37/EC**, and comply with the essential requirements of said Directive and the harmonised standards:

UNE-EN ISO 12100-1/2:2003  
UNE-EN 953:1997  
UNE-EN 563/A1/AC:2000

**Pressure equipment directive 97/23/EC**, the stated equipment has been designed and manufactured in accordance with the requirements of this Directive.

**Max working pressure:** DN 6 / ¼" a DN 80 / 3" = 7 bar

**Diameter:** DN 25

**Equipment category:** SEP = Sound Engineering Practice, determined according to Article 3, Section 1.3.a, first paragraph, annex II, table 6

**This material should not have the CE marking.**

**Diameter:** DN 25 < X < or = DN 100

**Equipment category:** Category I, determined according to Article 3, Section 1.3.a, first paragraph, annex II, table 6

**This material MUST have the CE marking.**

**Conformity Evaluation Module:** Module A

In conformity with **Regulation (CE) No. 1935/2004** on materials and objects intended to come into contact with foodstuffs (repealing 89/109/EEC), in accordance with which the materials in contact with the product do not transfer its constituents to the foodstuffs in quantities large enough to put human health at risk.

**Declaration of Incorporation** (Directive 98/37/EC, annex II, part B):

**The aforementioned equipment shall not be commissioned until the machine in which they will be incorporated has been declared as being in conformity with the Machine Directive.**

Banyoles, September 2009

  
Marc Pons Bague    Technical Manager

---

# 1. Safety

## 1.1. INSTRUCTION MANUAL

This manual contains basic instructions which should be fulfilled during the installation, starting and maintenance. The contents published in the instruction manual is based on updated information. INOXPA reserves the right to modify this instruction manual without prior notice.

## 1.2. START-UP INSTRUCTIONS

This instruction manual contains vital and useful information to correctly handle and maintain your valve. Not only should the safety instructions indicated in this chapter be observed and fulfilled, but so should the special measures and recommendations included in the other chapters of this manual. These instructions should be kept in a safe location near the installation.

## 1.3. SAFETY

### 1.3.1. Warning symbols.



Danger for persons in general



Danger of injury caused by rotating equipment parts.



Electrical danger



Danger! Caustic or corrosive agents.



Danger! Suspended loads



Danger to the correct operation of the equipment.



Commitment to safety at the workplace.



Protective goggles requirement.

## 1.4. GENERAL SAFETY INSTRUCTIONS



Read the instruction manual carefully before installing and starting up the valve. Contact INOXPA in case of doubt.

### 1.4.1. During the installation.



The *Technical Specifications* of Chapter 8 should always be observed.

The installation and use of the valve should always be carried out in accordance with applicable regulations regarding health and safety.

Before starting up the valve, confirm that the assembly is correct and that the shaft is perfectly aligned. Incorrect alignment and/or excessive force in securing the valve may cause serious mechanical problems in the valve. Check that the diaphragm has been correctly assembled, as incorrect assembly may cause serious damage to the valve.

### 1.4.2. During operation.



The *Technical Specifications* of Chapter 8 should always be observed. Never exceed the specified limits.



**NEVER** touch the valve and/or pipes that are in contact with the liquid during operation. If working with hot fluids, there is a risk of burns.



The valve contains parts operating with linear movement. Do not place your hands or fingers in the valve shut-off area. This may cause serious injuries.

#### 1.4.3. During maintenance



The *Technical Specifications* of Chapter 8 should always be observed.

**NEVER** disassemble the valve until the pipes have been drained. Bear in mind that the liquid in the pipe may be dangerous or extremely hot. Consult the regulations in effect in each country in these cases.

Do not leave parts loose on the floor.



All electrical work should be carried out by authorized personnel.

#### 1.4.4. In compliance with the instructions.

Any non-compliance with the instructions may result in a risk for the operators, the environment and the machine, and may result in the loss of your right to claim damages.

This non-compliance may result in the following risks:

- Failure of important functions of the machines/plant.
- Failure of specific maintenance and repair procedures.
- Possibility of electric, mechanical and chemical risks.
- Danger to the environment due to the release of harmful substances.

#### 1.5. GUARANTEE

Any guarantee will be negated immediately and, as a matter of law and in addition, we will require compensation for any claims of civil liability presented by third parties, in the instance of:

- The installation and maintenance work has not been carried out according to the instructions of this manual.
- The repairs are not carried out by our personnel or have been carried out without our written authorization.
- The parts used are not INOXPA genuine parts.
- Modifications have been carried out on our materials without written authorization.
- The material has been badly used, incorrectly used, or used with negligence or has not been used according to the indications and intended use specified in this manual.

The general conditions of delivery already in your possession are also applicable.



**No change can be made to the equipment without prior discussion with the manufacturer. For your safety, please use original spare parts and accessories.  
The use of other parts will exempt the manufacturer from any liability.**

**The service terms can only be changed with prior written authorization from INOXPA.**

Please do not hesitate to contact us in case of doubts or if more complete explanations are required on specific data (adjustments, assembly, disassembly, etc.).

---

## 2. Table of Contents

<b>1. Safety</b>	
1.1. Instruction manual .....	3
1.2. Start-up instructions .....	3
1.3. Safety .....	3
1.4. General safety instructions.....	3
1.5. guarantee.....	4
<b>2. Table of Contents</b>	
<b>3. Delivery and Installation</b>	
3.1. Checking the shipment .....	6
3.2. Delivery and unpacking .....	6
3.3. Storage .....	6
3.4. Identification .....	7
3.5. Location .....	8
3.6. Flow direction .....	8
3.7. Assembly .....	8
3.8. Inspecting and checking .....	9
3.9. Welding .....	9
3.10. Air connection to actuator.....	10
<b>4. Start-up</b>	
4.1. Start up .....	11
4.2. Operation .....	11
<b>5. Operating problems: Causes and solutions</b>	
<b>6. Maintenance</b>	
6.1. General .....	13
6.2. Maintenance .....	13
6.3. Cleaning .....	14
<b>7. Assembly and disassembly</b>	
7.1. Disassembly / assembly of the manually actuated valve .....	15
7.2. Disassembly / assembly of the pneumatically actuated valve .....	16
<b>8. Technical Specifications</b>	
8.1. Valve dimensions .....	18
8.2. Section and parts list.....	20

# 3. Delivery and Installation

## 3.1. CHECKING THE SHIPMIENT

On receipt of the valve check to verify that it agrees with the delivery note.

INOXPA inspects all its equipment before packing but we cannot guarantee that the goods will arrive undamaged to the user.

For this reason, the valve and any other components received should be checked and, if found not to be in good condition and/or not complete the carrier should submit a report as soon as possible. Each valve has a manufacturing number engraved on the nameplate. Indicate the manufacturing number in all documents and correspondence.

Serial Number →

VALVULAS NEUMATICAS / AIR OPERATED VALVES	
NºFIGURA: <i>FIGURE NR:</i>	TAMAÑO: <i>SIZE:</i>
TIPO ACTUADOR: <i>ACTUATOR TYPE:</i>	
PRESION DE TRABAJO:min <i>WORKING PRESSURE:min</i>	/máx <i>/max</i>
Nº FABRICACION: <i>MANUFACTURING NR.:</i>	MODELO: <i>MODEL:</i>

## 3.2. DELIVERY AND UNPACKING



**INOXPA will not be responsible for the inappropriate unpacking of the valve and its components.**

### 3.2.1. Delivery:

Check all the parts indicated on the delivery note.

- Complete valve.
- Its components (if supplied).
- Delivery note.
- Instruction manual.

### 3.2.2. Unpacking:

- Remove all traces of packing materials from the valve or parts.
- Inspect the valve or its constituent parts for possible damage caused during transport.
- Avoid any possible damage to the valve and its components.

## 3.3. STORAGE

If the valve and/or diaphragm are not going to be assembled for immediate use, but stored for later installation, they must be stored in a closed area according to the following conditions:

Temperature	from 15°C to 30°C
Relative humidity	<60%
Away from sunlight	Store in opaque bags

Open-air storage of the equipment is **NOT** allowed.



**For valves that must be stored for a long period, the casing must be disassembled, as the diaphragm may become excessively deformed and/or damaged. In order to disassembly the casing, see paragraphs 7.1 and 7.2 of the Chapter *Assembly and Disassembly*.**

For optimum performance of the diaphragms do not keep them in storage for more than 3 years. After this time, they may degrade and lose their properties.

3.4. IDENTIFICATION

**V1 5 0 0 77 06 52 015**

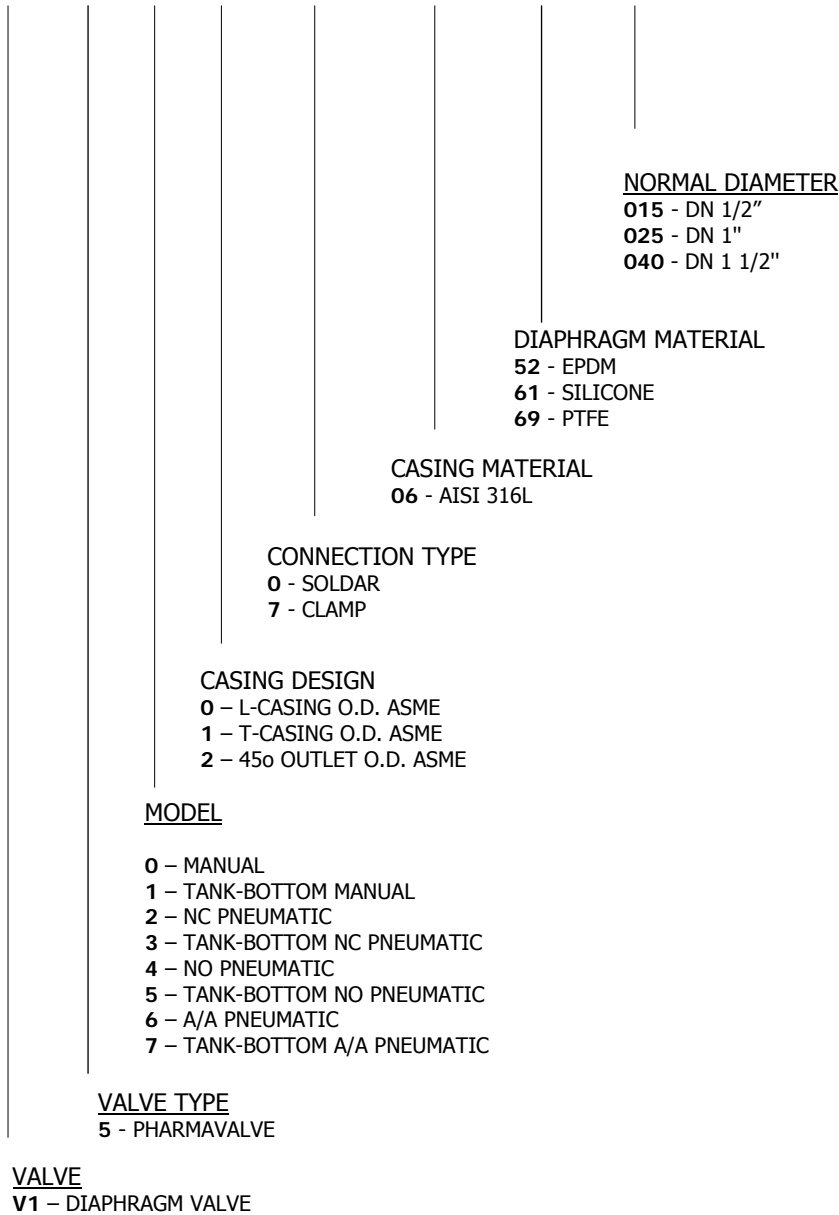



The buyer or user will be responsible for the assembly, installation, starting and operation of the valve.

### 3.5. LOCATION

Place the valve in such a way as to facilitate inspections and checks. Leave sufficient space around the valve for appropriate inspection, disassembly and maintenance (See Section 3.9.1).

When installing the actuator, allow a minimum free surrounding space of about 100 mm so that the valve can be disassembled. If there are accessories such as position sensors, travel limits, etc., you must allow an addition space for disassembly of these elements.

### 3.6. FLOW DIRECTION

PHARMAVALVE valves can combine the drives with various types of bodies as described below.

The flow direction in L-type bodies can be as shown in figures *a* or *b* below. The flow in direction *a* is the recommended direction, as there is less pressure loss and fewer dead zones, due to the direction of closure.

In T-type bodies, the normal direction is shown in figure *c*, as it minimises pressure losses and dead zones. T-type casings are **NOT** 3-way valves; they act as a divider when the valve is closed, and as a T when it is open.

L-type shut-off valve

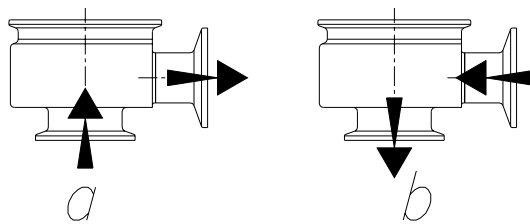

T-type shut-off valve

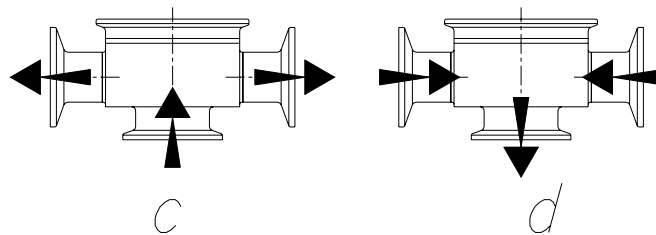

10.320.32.00102

### 3.7. ASSEMBLY

Once the location of the valve is defined, the pipe can be connected by welding the bodies of the valve or by means of a clamp fitting. In this case, do not forget the seals and to fully tighten the wing nut.

All the casings have hygienic clamp connections as standard at both the inlet and outlet. Butt weld connections are also available as an option.



Before starting welding of the body to the piping or tanks, disassemble the valve to avoid damaging the diaphragms.

Excessive stress should be avoided during the assembly of the valves and special attention should be given to the following:

- Vibration which may be produced in the installation.
- Expansion of the pipes during circulation of hot liquids.
- The weight that the pipes can withstand.
- Excessive intensity of welding.



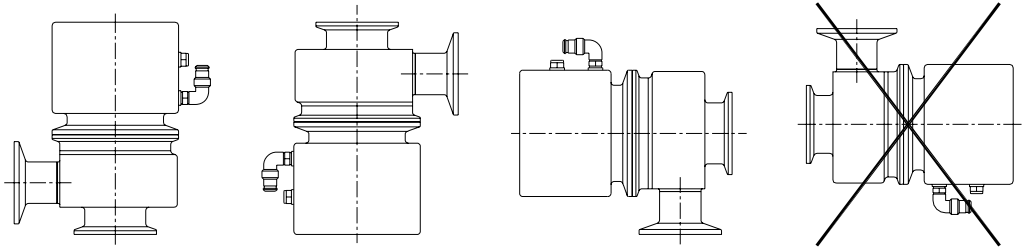

DRAINABLE POSITIONS

**NOT** DRAINABLE

10.320.32.00101

To ensure that the valves are completely drainable, they must be placed in the positions shown in the figure above.

### 3.8. INSPECTING AND CHECKING

Check the following before use:

- Check that the clamps are fully tightened. See the tightening torque in chapter 8. *Technical Specifications*.
- Open and close the valve (applying compressed air to the actuator or moving manually if a handle is available) several times to ensure that it operates correctly. Check that the diaphragm fully closes.

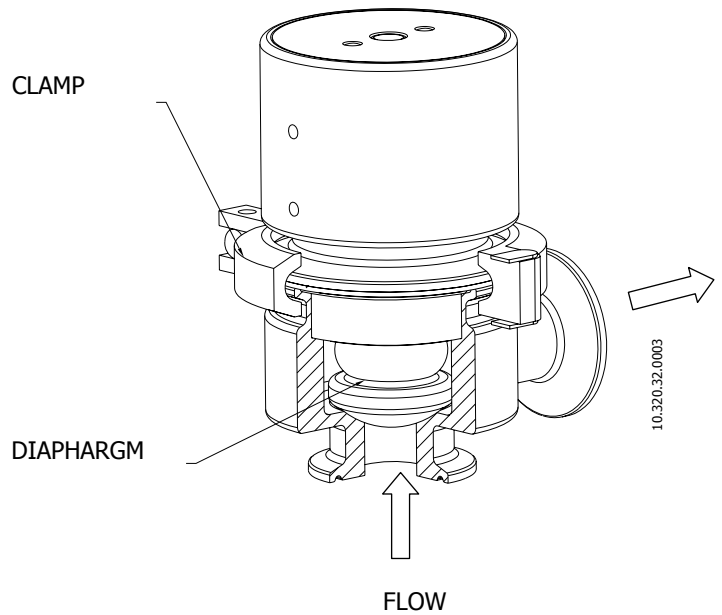

10.320.32.00003

### 3.9. WELDING



The welding work can only be carried out by persons qualified, trained and equipped with the necessary means to carry out this work.

Disassemble the valve before starting the welding work.

#### 3.9.1. PHARMAVALVE - Butt Weld connections

- Disassemble the valve as indicated in Chapter 7. *Assembly and disassembly*.
- Weld the body of the valve into the pipe work preferably using orbital welding.
- When welding the valve body, it is very important to maintain the minimum distance (see figure below) enabling disassembly of the valve for later checks and replacement of valve parts (diaphragm, actuator...).

DN	A	B
1/2"	110	110
1"	160	160
1 1/2"	170	180

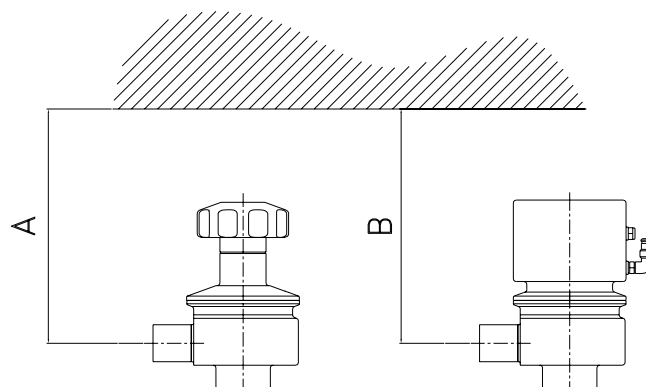

10.320.32.00112

### 3.9.2. PHARMAVALVE - Tank Bottom.

The tank-bottom body is usually placed as shown in the figure below.  
The distance of the body weld to another weld must be at least 3 times the tank thickness.

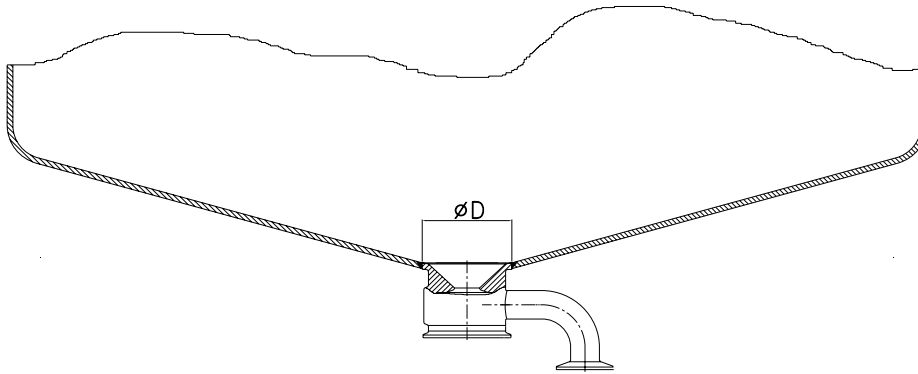

10.320.32.0004

- In order to weld the casing on the tank, a hole with the following diameter must be made:

Valve size	Diameter D
DN 1/2"	50mm
DN 1"	79mm
DN 1 1/2"	100mm

And the following conditions must be taken into account:

- Polish the edges of the hole being prepared for welding.
- Ensure that the body outlet is correctly oriented.
- Place the weld points on the exterior of the casing (TIG welding). The filler material is determined according to the material of the body and tank.
- Seal and fill the space between the tank base and the main base with inert gas.
- Starting from the outside, weld the body in a single operation. Make sure that the material has melted and penetrated correctly, and is free of pores and cracks. Use as little heat as possible (low intensity). High intensity may deform the valve.
- Continue welding until the body is completely welded.
- Leave to cool gradually. Cool by air only
- Turn over the tank base and weld from the inside.
- Leave to cool gradually. Cool by air only.
- Polish the inside and outside until the required surface finish has been achieved.

### 3.10. AIR CONNECTION TO ACTUATOR

- Connect and check the air connections as needed: Double or Single acting
- INOXPA valves are supplied with Ø4 tube connections and a silencer in S/A actuators.
- Bear in mind the quality of the compressed air in accordance with the specifications described in chapter 8 *Technical Specifications*.



**The compressed air pressure for the actuators A/A (double acting) is less than in type NC (normally closed)). See chapter 8 *Technical specifications*. Excessive pressure can seriously damage the diaphragm.**

The pneumatic actuator is available in two versions:

- N-C: Spring closed, Air open
- A-A: Air closed, Air open

**M5 Thread  
pneumatic  
connections for all  
sizes.**

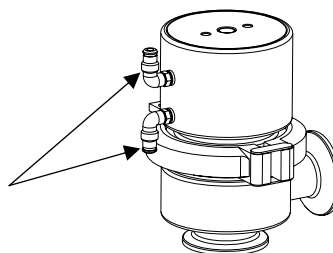

10.320.32.0005

# 4. Start-up

The start-up of the valve can be carried out provided the instructions indicated in Chapter 3 - *Receipt and Installation* have already been followed.

## 4.1. START UP



**Before start-up, the responsible persons should be duly informed of the operation of the valve and the safety instructions to be followed. This instruction manual should be available to personnel at all times.**

The following should be taken into consideration before starting-up the valve/actuator:

- Check that the pipe and valve are completely free from any traces of welding or other foreign matter. Carry out the cleaning of the system if required.
- Verify the smooth operation of the valve. If necessary, lubricate with special grease or soapy water.
- Check for possible leaks and check that all the pipes and connections are watertight and free from leaks.
- If the valve is supplied with an actuator, ensure that the actuator allows for a smooth movement.
- Check that the compressed air pressure at the intake to the actuator is that indicated in the Chapter 8. *Technical Specifications*.
- Bear in mind the quality of the compressed air in accordance with the specifications described in chapter 8 *Technical Specifications*.
- Operate the valve.

## 4.2. OPERATION



**Do not touch the moving parts of the valve when the actuator is connected to the compressed air. Never place your fingers inside the casing when a pneumatic actuator has been fitted.**



**Do not modify the operating parameters for which the valve has been designed without written prior authorization from INOXPA.**

**Danger of burns! Do not touch the valve or pipes when hot liquids are circulating or when cleaning and/or sterilisation are being carried out.**

Visually check that the sealed area has no leaks. The valves are provided with a leak detector. The valve must be oriented so that the leak detector is visible to all staff at the plant. In the case of leak, the diaphragm must be replaced and the sealed area of the actuator must be cleaned to remove any remaining product.

Place the valve so that in the event of losses through the detector there is no danger of personal injury. This is especially the case if hot liquids are being circulated or cleaning and/or sterilisation is being carried out.

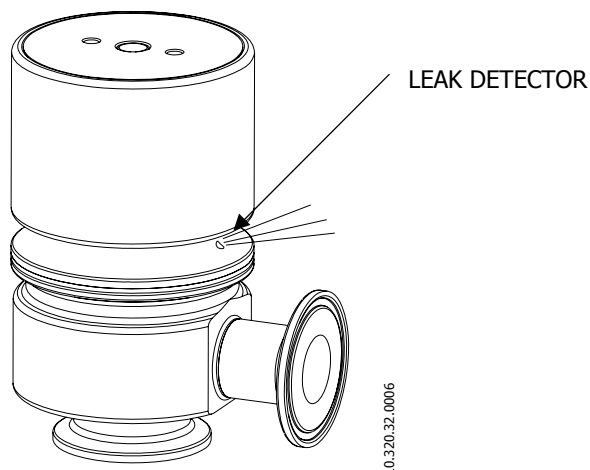

# 5. Operating problems: Causes and solutions

PROBLEM	CAUSE/EFFECT	SOLUTION		
THE MOVEMENT OF THE VALVE DIAPHRAGM IS UNSTEADY	The diaphragm or guide bushing have become worn, deteriorated, or blocked up.	<ul style="list-style-type: none"> <li>• Replace the diaphragm.</li> <li>• Replace the diaphragm with one of a different material and more appropriate to the product.</li> <li>• Lubricate with soapy water or lubricant compatible with the material of the diaphragm and with the product.</li> </ul>		
	Insufficient air pressure.	<ul style="list-style-type: none"> <li>• Increase the compressed air pressure.</li> </ul>		
INTERNAL LEAK OF THE PRODUCT (CLOSED VALVE)	Normal wear of the diaphragm.	<ul style="list-style-type: none"> <li>• Replace the diaphragm.</li> </ul>		
	<table border="1"> <tr> <td>Premature wear of the diaphragm.</td> <td> <ul style="list-style-type: none"> <li>• Diaphragm worn or damaged by the fluid.</li> <li>• Excessive pressure in the line.</li> <li>• Working temperature too high</li> <li>• Loss of water tightness (vibration).</li> </ul> </td> </tr> </table>	Premature wear of the diaphragm.	<ul style="list-style-type: none"> <li>• Diaphragm worn or damaged by the fluid.</li> <li>• Excessive pressure in the line.</li> <li>• Working temperature too high</li> <li>• Loss of water tightness (vibration).</li> </ul>	<ul style="list-style-type: none"> <li>• Replace the diaphragm with one of a different material and more appropriate to the product.</li> <li>• Tighten any loose components.</li> <li>• Clean frequently.</li> <li>• In actuators NO and A/A, reduce the air pressure.</li> </ul>
	Premature wear of the diaphragm.	<ul style="list-style-type: none"> <li>• Diaphragm worn or damaged by the fluid.</li> <li>• Excessive pressure in the line.</li> <li>• Working temperature too high</li> <li>• Loss of water tightness (vibration).</li> </ul>		
Backpressure	<ul style="list-style-type: none"> <li>• Increase the compressed air pressure.</li> <li>• Replace the actuator with a dual effect one.</li> <li>• Reduce the line pressure.</li> </ul>			
LEAK IN LEAK DETECTOR	Broken diaphragm	<ul style="list-style-type: none"> <li>• Replace the diaphragm</li> </ul>		
VALVE DOES NOT OPEN/CLOSE	<p>The diaphragm is jammed</p> <p>The diaphragm is not properly fitted in the actuator</p> <p>Incorrect fluid flow, combined with high fluid pressure.</p> <p>Actuator broken.</p>	<ul style="list-style-type: none"> <li>• Inspect the diaphragm and replace if necessary.</li> <li>• Fit correctly. Depending on whether the diaphragm is fitted by pressing on or screwing on to the shaft.</li> <li>• Change direction of the fluid and lower the pressure.</li> <li>• Replace the actuator</li> </ul>		
HYDRAULIC SHOCK	The valve closes too fast.	<ul style="list-style-type: none"> <li>• Adjust the closing speed of the actuator (with a flow regulator).</li> </ul>		
THE ACTUATOR LOSES AIR	Actuator gaskets worn	<ul style="list-style-type: none"> <li>• Replace the actuator</li> </ul>		

# 6. Maintenance

## 6.1. GENERAL

This valve, just like any other machine, requires maintenance. The instructions contained in this manual cover the identification and replacement of spare parts. The instructions have been prepared for maintenance personnel and for those responsible for the supply of spare parts.



Carefully read Chapter 8. *Technical Specifications*.

All replaced material should be duly disposed of/recycled according to the directives in effect in the area.

Assembly and disassembly of the valves must only be carried out by qualified staff.

Before starting on maintenance work, ensure that the pipe work is not pressurised.

## 6.2. MAINTENANCE

The following is recommended for appropriate maintenance:

- Regular inspection of the valve and its components.
- Keep a record of the operation of each valve, noting any incidents.
- Always have spare gaskets in stock.

During maintenance, pay particular attention to the danger warnings indicated in this manual.



The valve and pipes should not be pressurised during maintenance.

The valve should not be hot during maintenance. Danger of burns!

### 6.2.1. Diaphragm Maintenance.

REPLACING THE DIAPHRAGM	
Preventive maintenance	<p>Replace after twelve (12) months.</p> <p>In general, the diaphragm must be inspected every 50 hours of sterilisation (steam or superheated water)</p> <p>The time interval between each preventive maintenance may vary according to the working conditions to which the valve is submitted: Temperature, pressure, number of operations per day, type of cleaning solutions used, etc.</p> <p>The following can be used as a general guide:</p> <ul style="list-style-type: none"> <li>• For water under 100°C, inspect the diaphragm every 1000 working hours.</li> <li>• For steam above 100°C, with a maximum of 135°C, inspect the diaphragm every 50 hours of exposure.</li> <li>• For EPDM diaphragms constantly subjected to steam, check every 250 hours. (use an on/off valve before the PHARMAVALVE to prolong the life of the EPDM diaphragm)</li> </ul>
Maintenance after a leak	Replace at the end of the process.
Scheduled maintenance	<p>Regularly check that there are no leaks and that the valve is operating smoothly.</p> <p>Keep a record of the valve.</p> <p>Use statistics to plan inspections.</p>
Lubrication	During assembly, apply lubricants compatible with the diaphragm material. See the following table.

SEAL COMPONENT	LUBRICANT	Class NLGI DIN 51818
VMQ	Klübersynth UH 1 64-2403	3
EPDM	PARALIQ GTE 703	3

### 6.2.2. Storage

Storage of the valves should be carried out in an enclosed area, under the following conditions:

Temperature from 15°C to 30°C

Relative humidity <60%

Open-air storage of the equipment is **NOT** allowed.

### 6.2.3. Spare parts

To request spare parts, it is necessary to indicate the type of valve, the position and the description of the part which can be found in the *Technical Specifications* chapter.

## 6.3. CLEANING



The use of aggressive cleaning products such as caustic soda and nitric acid may cause burns to the skin.

Use rubber gloves during the cleaning process.



Always use protective goggles.

### 6.3.1. CIP (Clean-in-place) cleaning

If the valve is installed in a system provided with the CIP process, its disassembly will not be required.

Cleaning solutions for CIP processes.

Only use clear water (chlorine-free) to mix with the cleaning agents:

a) **Alkaline solution:** 1% by weight of caustic soda (NaOH) at 70°C (150°F)

1 Kg NaOH + 100 l. of water = cleaning solution

or

2,2 l. NaOH at 33% + 100 l. of water = cleaning solution

b) **Acid solution:** 0.5% by weight of nitric acid (HNO<sub>3</sub>) at 70°C (150°F)

0.7 litres HNO<sub>3</sub> at 53% + 100 l. of water = cleaning solution



Check the concentration of cleaning solutions; it may cause the deterioration of the watertight seals of the valve.

To remove any remains of cleaning products, ALWAYS perform a final rinse with clean water on completion of the cleaning process.



Before beginning the disassembly and assembly work, clean the valve inside as well as outside.

### 6.3.2. Automatic SIP (sterilisation-in-place)

The steam-sterilisation process is applied to all equipment.



**DO NOT operate the equipment during the steam-sterilisation process.**

The parts/elements will not suffer damage provided the instructions set out in this manual are followed.

Cold liquid cannot be introduced until the equipment temperature is below 60°C (140°F).

Maximum conditions during the steam or superheated-water SIP process

- a) Max. temperature: 140°C / 284°F
- b) Max. time: 30 mins
- c) Cooling: Sterilised air or inert gas
- d) Materials: EPDM / PTFE / VMQ

# 7. Assembly and disassembly



Proceed with caution. There is danger of personal injury.

Never disassemble the valve screws directly without reading the instructions thoroughly.



Assembly and disassembly of the valves / actuator must only be carried out by qualified staff.

## 7.1. DISASSEMBLY / ASSEMBLY OF THE MANUALLY ACTUATED VALVE

### Disassembly

1. Turn the actuator handle (10) so that the valve is in the open position.  
Remove the clamp (34).  
Remove the actuator (10) from the body (01).  
Detach the diaphragm (05). It must be removed differently depending on whether it is a type A or type B actuator (see figure below).

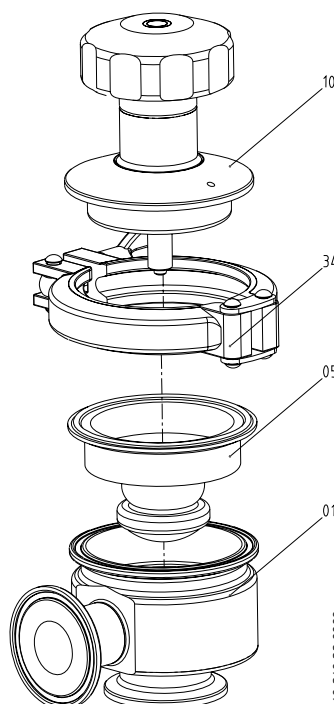

### Assembly

1. Locate the diaphragm (05) on the driveshaft as appropriate for type A or B.
2. Place the actuator (10) in the open valve position.  
Connect the body (01) to the actuator (10) using the clamp (34)

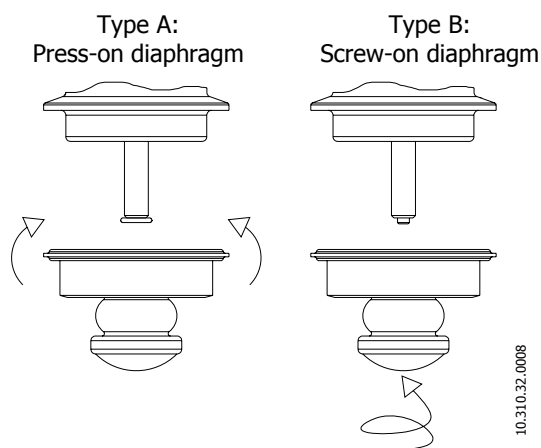

Valve size	Silicone and EPDM Diaphragm fastener type	PTFE diaphragm fastener type
DN 1/2"	A	-
DN 1"	A / B	B
DN 1 1/2"	A / B	B

The type A diaphragm (press-on) is standard for Silicone and EPDM. In certain circumstances, when the valve has been closed for a long time, running dry or during sterilisation cycles, the diaphragm may become dislodged. In order to prevent this, use connection type B (threaded diaphragm), which holds the diaphragm better. Consult Inoxpa before replacing one diaphragm type with another.



Proceed with caution. There is danger of personal injury.

Never disassemble the valve clamp directly without reading the instructions thoroughly.



Assembly and disassembly of the valves / actuator must only be carried out by qualified staff.

## 7.2. DISASSEMBLY / ASSEMBLY OF THE PNEUMATICALLY ACTUATED VALVE

### Disassembly

1. Apply compressed air to the actuator (10) in order to set the diaphragm (05) in the open position. (NC valve only)
2. Remove the clamp (34) from the actuator (10).
3. Remove the actuator (10) from the body (01).
4. Detach the diaphragm (05). It must be removed differently depending on whether it is a type A or type B actuator (see figure below).

### Assembly

5. Locate the diaphragm (05) on the actuator shaft (10), as appropriate for type A or B.
6. Apply compressed air to the actuator (10) in order to set the diaphragm (05) in the open position. (NC valve only)

Connect the body (01) to the actuator (10) by tightening the clamp (34)

Disconnect the compressed air from the actuator (1) so that the diaphragm (05) is set to the closed position.

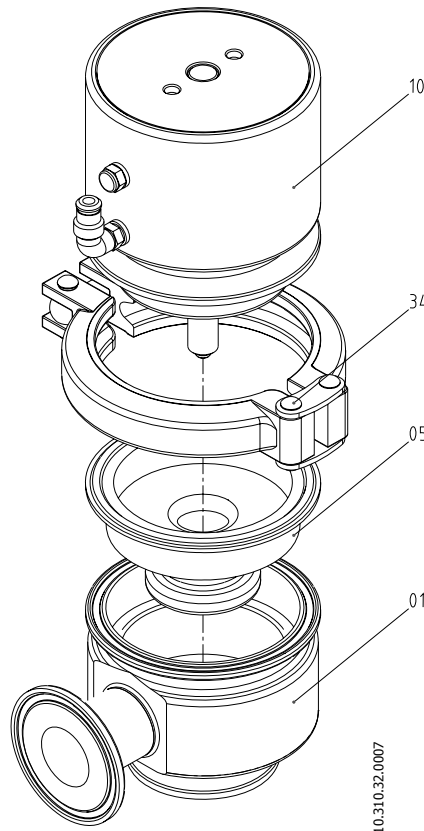

Type A:  
Press-on diaphragm

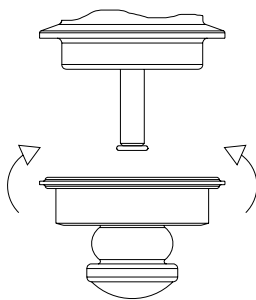

Type B:  
Screw-on diaphragm

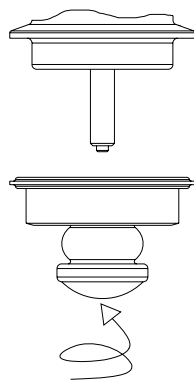

10.310.32.0008

Valve size	Silicone and EPDM Diaphragm fastener type	PTFE diaphragm fastener type
DN 1/2"	A	-
DN 1"	A / B	B
DN 1 1/2"	A / B	B

The type A diaphragm (press-on) is standard for Silicone and EPDM. In certain circumstances, when the valve has been closed for a long time, running dry or during sterilisation cycles, the diaphragm may become dislodged. In order to prevent this, use connection type B (threaded diaphragm), which holds the diaphragm better. Consult Inoxpa before replacing one diaphragm type with another.



# 8. Technical Specifications

## VALVE GENERAL DATA

<i>Maximum operating pressure (bar/PSI)</i>				
DN	Manual actuation		Pneumatic actuation	
	EPDM/VMQ	PTFE	EPDM/VMQ	PTFE
DN ½"	7 bar /101 PSI	7 bar /101 PSI	7 bar /101 PSI	7 bar /101 PSI
DN 1"	7 bar /101 PSI	7 bar /101 PSI	7 bar /101 PSI	7 bar /101 PSI
DN 1 ½"	7 bar /101 PSI	7 bar /101 PSI	7 bar /101 PSI	7 bar /101 PSI
Minimum working pressure	Vacuum			
Maximum working temperature	Manual valve		Pneumatic valve	
	135°C (SIP) 135°C (Autoclave)		135°C (SIP)	
Compressed air pressure	4-6 bars (NC actuator) (87-116 PSI), 3-4 bars (43.5-58 PSI) (A/A actuator)			
Clamp tightening torque	5 N·m			
Compressed air quality	In accordance with DIN/ISO 8573.1 <ul style="list-style-type: none"> <li>○ <u>Solid-particle content</u>: Class-3 quality / Max. particle size 5 microns / Max. particle density 5 mg/m<sup>3</sup></li> <li>○ <u>Water content</u>: Class-4 quality / max. dew point +2 °C. If the valve is operating at high altitude or low ambient temperature, the dew point must be adjusted accordingly.</li> <li>○ <u>Oil content</u>: Class-5 quality, preferably oil-free / max. 25 mg oil per 1 m<sup>3</sup> air.</li> </ul>			
Compressed air connection	M5 connection with 4 mm diameter tube			
Compressed air consumption	SIZE	Litres (normal) at 4 bars		
	DN ½"	0.03		
	DN 1"	0.12		
	DN 1 ½"	0.3		

## VALVE MATERIALS

Parts in contact with the product	AISI 316L
Other steel parts	AISI 316
Seals in contact with the product	SILICONE (Standard) - EPDM – PTFE
Steel parts surface finish	In contact with the product: Ra ≤ 0.5 µm (Standard) External surfaces: Satin-finished
Type of connections	DIN 11851, Butt Weld, BS-RJT, SMS, Clamp, Bidas, Macon.

## 8.1. VALVE DIMENSIONS

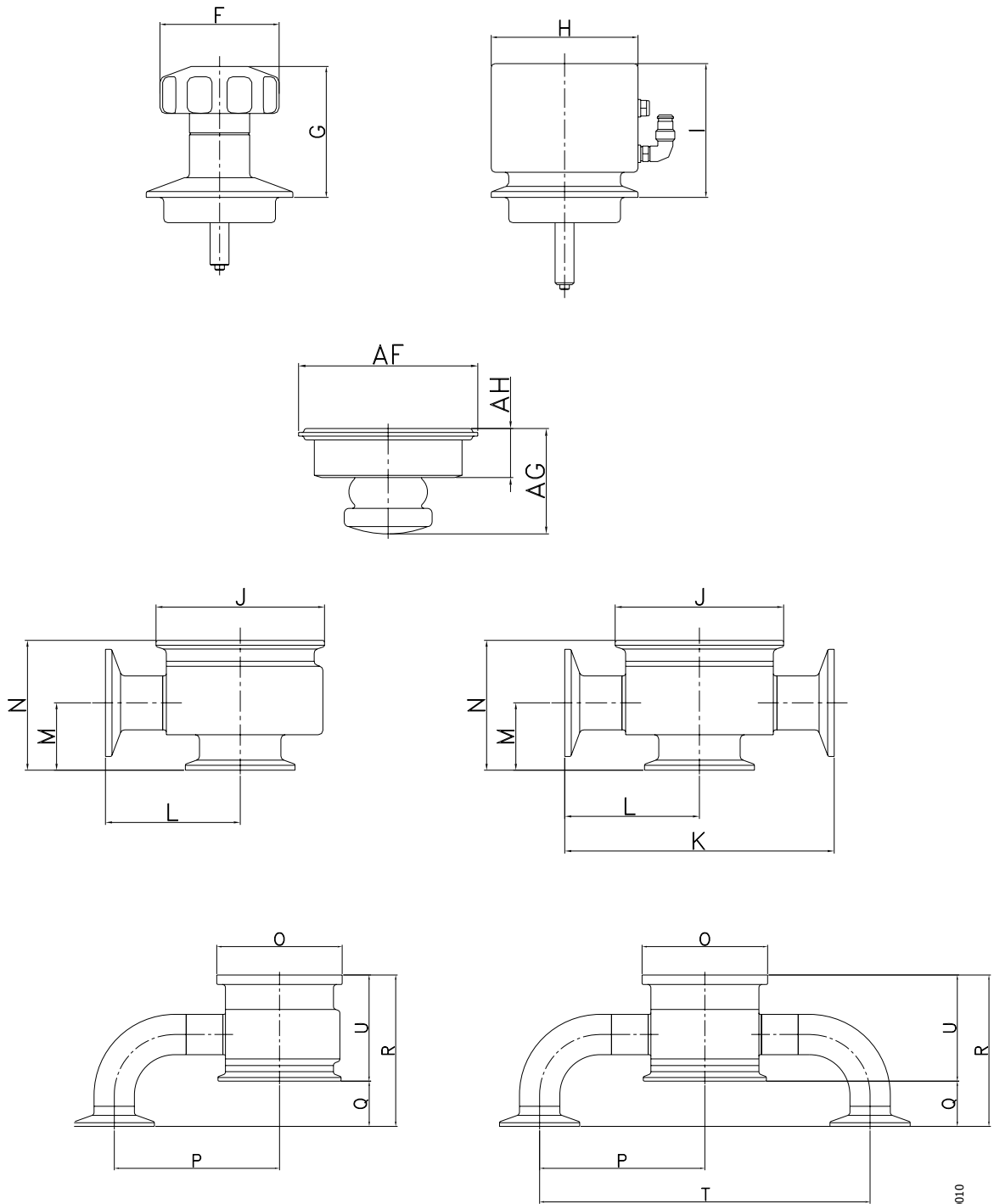

10.310.32.0010

		<b>1/2"</b>	<b>1"</b>	<b>1 1/2"</b>
<b>Manual Actuator</b>	<b>F</b>	Ø55	Ø63	Ø63
	<b>G</b>	45-56	65-72	64-74
<b>Pneumatic Actuator</b>	<b>H</b>	Ø42	Ø77.5	Ø94.5
	<b>I</b>	60	69	90
<b>Bodies</b>	<b>J</b>	TC50.5	TC77.5	TC77.5
	<b>k</b>	82	124	124
	<b>L</b>	41	62	62
	<b>M</b>	19.5	32	37.5
	<b>N</b>	36.5	61.2	67.2
	<b>O</b>	Ø50	Ø79	Ø100
	<b>P</b>	47	104	120
	<b>Q</b>	-	28.5	52
	<b>R</b>	60	95,5	121.7
	<b>T</b>	94	208	240
	<b>U</b>	35	67	69,7
<b>Diaphragm (Silicone/EPDM)</b>	<b>AF</b>	Ø50.5	Ø77.5	Ø77.5
	<b>AG</b>	31	50	57
	<b>AH</b>	13.5	20.5	15

## 8.2. SECTION AND PARTS LIST

### 8.2.1. Section and parts list MANUALLY ACTUATED VALVE

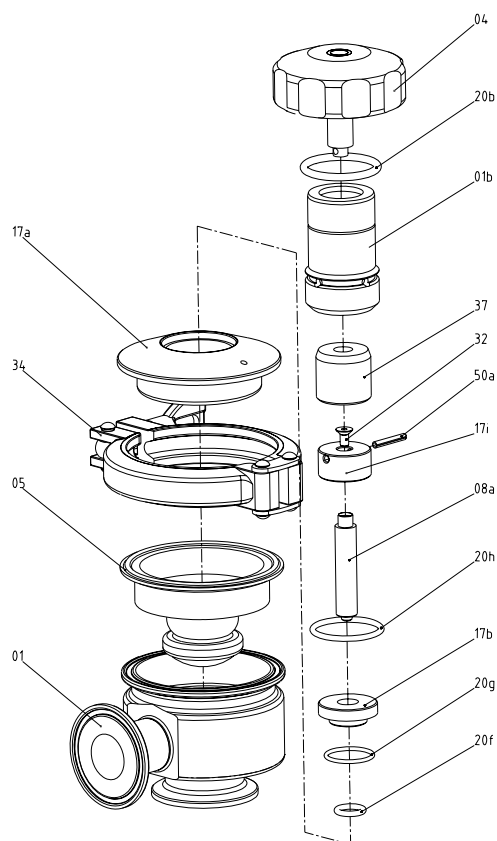

10.320.32.0011

POSITION	DESIGNATION	MATERIAL	QUANTITY
01	Body	AISI 316L	1
01B	Nut support	AISI 316L	1
04	Handle	AISI 316	1
05	Diaphragm	-	1
08	Diaphragm shaft	AISI 316	1
17A	Support bushing	AISI 316	1
17B	Guide bushing	PTFE	1
17I	Bearing bushing	AISI 316	1
20B	O-ring	FPM	1
20G	O-ring	FPM	1
20H	O-ring	FPM	1
20F	O-ring	FPM	1
32	Countersunk screw	AISI 304	1
34	Clamp	AISI 304	1
37	Nut	Brass	1
50	Pin	AISI 304	1

## 8.2.2. Section and parts list PNEUMATIC ACTUATION

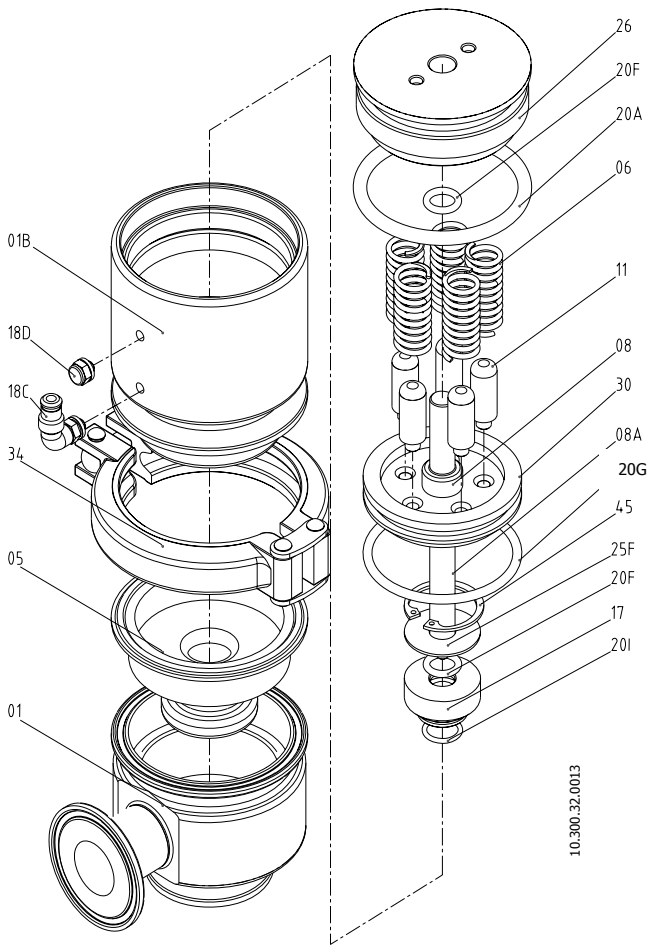

POSITION	DESIGNATION	MATERIAL	QUANTITY
01	Casing	CF 3M	1
01B	Actuator casing	AISI 316L	1
05	Diaphragm	-	1
06	Spring	AISI 302	5
08	Piston shaft	AISI 316L	1
08A	Diaphragm shaft	AISI 316L	1
11	Spring guide	POM	1
17	Guide bushing	PTFE	1
18C	R 1/8" straight connector	-	1
18D	R 1/8" Silencer	-	1
20A	O-ring	FPM	1
20F	O-ring	FPM	1
20G	O-ring	FPM	1
20H	O-ring	FPM	1
25F	Washer	AISI 316L	1
26	Actuator cap	AISI 316L	1
30	Piston	Aluminium	1
45	Elastic ring	AISI 316L	1

---

## Клапаны — Радиальный мембранный клапан Pharmavalve

<http://k-tep.com.ua/>

✉ [k-tep@ukr.net](mailto:k-tep@ukr.net)

■ Office +38 044 2091823

■ МТС +38 066 9076563

■ Киевстар +38 098 3676414

Skype: [k-teppumps](#)

### **Замечания**

*Условия поставки: DDP склад г. Киев*

#### **Заметки**

Время поставки рассчитано согласно дате предложения и изменяется в зависимости от даты подтверждения заказа.

Размещая заказ, покупатель принимает предложение и все спецификации, характеристики и условия, указанные в данном документе.