

**Инструкция по установке, эксплуатации и
обслуживанию**

Распределительный односедельный клапан К

**INSTALLATION, SERVICE AND
MAINTENANCE INSTRUCTIONS**

SINGLE-SEAT VALVE



c/Telers, 54 Aptdo. 174
E-17820 Banyoles
Girona (Spain)

ISO 9001
BUREAU VERITAS
Certification



Original Manual's Translation

10.210.30.00EN_RevC
ED. 2009/11



EC DECLARATION OF CONFORMITY

(according to Directive 98/37/CE, annex II, part A)

Manufacturer:

C/ Telers, 54
17820 Banyoles (Girona) - SPAIN

Hereby declares, that the product:

<u>VALVE</u>	<u>SINGLE SEAT – N/K/M</u>	<u>2015</u>
Name	Type	Year of manufacture

conforms to the specifications of the Council Directive:

Machine Directive 98/37/CE, and complies with the essential requirements of the Directive and Harmonised Standards:

UNE-EN ISO 12100-1/2:2004
UNE-EN 953:1997
UNE-EN ISO 13732-1:2007

Pressure Equipment Directive 97/23/CE, the equipment has been designed and manufactured in accordance with the requirements of the Directive.

Max operating P.: DN-25/1" to DN-100/4" = 10 bar

Diameter: DN-25

Equipment category: SEP = Sound Engineering Practice, determined according to Article 3 Section 1.3.a, first paragraph Annex II, Table 6

This material SHALL NOT carry CE marking.

Diameter: DN-25 < X < ó = DN-100

Equipment category: Category I, determined according Article 3 Section 1.3.a, first paragraph Annex II, Table 6

This material SHALL carry CE marking.

Conformity Assessment Module: Module A

In compliance with the Regulations **(CE) n° 1935/2004**, relating to materials and articles intended to come into contact with foodstuff (repeal Directive 89/109/CEE), the materials in contact with the product do not transfer their components in quantities which may jeopardise consumer's health or safety.

Declaration of Incorporation (Directive 98/37/CE, annex II, part B):

The equipments above mentioned won't put to operation till the machine into or onto it will be installed must comply with the stipulations of the Machine Directive.

Banyoles, November 2015

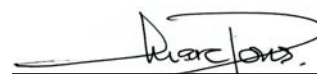
Marc Pons Bague Technical Manager

1. Safety

1.1. INSTRUCTION MANUAL.

This instruction manual contains basic indications which should be fulfilled during the installation, starting and maintenance. The information published in the instruction manual is based on updated information. INOXPA reserves the right to modify this instruction manual without prior notice.

1.2. INSTRUCTIONS FOR START-UP.

This instruction manual contains vital and useful information to appropriately handle and maintain your valve. Not only should the safety instructions indicated in this chapter be observed and fulfilled, but so should the special measures and recommendations included in the other chapters of this manual. These instructions should be kept in a safe location near the installation.

1.3. SAFETY.

1.3.1. Warning symbols.



Danger for persons in general



Danger of injury caused by rotating equipment parts.



Electric danger



Danger! Caustic or corrosive agents.



Danger! Suspended loads



Danger for the correct operation of the equipment.



Commitment to safety at the workplace.



Protective goggles requirement.

1.4. GENERAL SAFETY INSTRUCTIONS.



Read the instruction manual carefully before installing and starting up the valve. Contact INOXPA in case of doubt.

1.4.1. During the installation.



The *Technical Specifications* of Chapter 8 should always be observed.

The installation and use of the valve/actuator should always be carried out in accordance with applicable regulations regarding health and safety.

Before starting up the valve/actuator, verify that the assembly is correct and that the shaft is perfectly aligned. An incorrect alignment and/or excessive force in securing the valve/actuator may cause serious mechanical problems in the valve/actuator.



During the installation, all the electric work should be carried out by authorised personnel.

1.4.2. During operation.



The *Technical Specifications* of Chapter 8 should always be observed. Under no circumstances can the limit values specified be exceeded.



NEVER touch the valve and/or pipes in contact with the liquid during operation; there is a risk of burns if it operates with hot products.

Do not operate the handlever in case of failure; the springs are not protected.



The valve/actuator contains rotating parts. Do not place the fingers or hands in the coupling between the valve and the actuator when the compressed air is connected; this may cause serious injuries.

1.4.3. During maintenance



The *Technical Specifications* of Chapter 8 should always be observed.

NEVER disassemble the valve until the pipes have been emptied. Bear in mind that the liquid in the pipe may be dangerous or extremely hot. Consult the regulations in effect in each country for these cases.

Do not leave parts loose on the floor.



All the electric work should be carried out by authorised personnel.

1.4.4. In compliance with the instructions.

Any nonfulfillment of the instructions may result in a risk for the operators, the environment and the machine, and may result in the loss of rights to make claims.

This nonfulfillment may result in the following risks:

- Failure of important functions of the machines/plant.
- Failure in specific maintenance and repair procedures.
- Possibility of electric, mechanical and chemical risks.
- Will place the environment in danger due to the release of substances.

1.5. GUARANTEE.

Any guarantee will be cancelled immediately and as a matter of law and, in addition, we will require compensation for any claims of civil liability presented by third parties, in case:

- The installation and maintenance work has not been carried out according to the instructions of this manual.
- The repairs are not carried out by our personnel or have been carried out without our written authorisation.
- The parts used are not INOXPA genuine parts.
- Modifications have been carried out on our materials without written authorisation.
- The material has been badly used, incorrectly used, or used with negligence or has not been used according to the indications and intended use specified in this manual.

The general conditions of delivery already in your possession are also applicable.

Please do not hesitate to contact us in case of doubts or more complete explanations are required on specific data (adjustments, assembly, disassembly, etc.).

2. Table of contents

1. Safety	
1.1. Instruction Manual.	3
1.2. InstrucTions FOR START-UP.	3
1.3. SAFETY.	3
1.4. GENeRAL SAFETY InstrucTions.	3
1.5. Guarantee.	4
2. Table of contents	
3. Receiving and installing	
3.1. Check the shipment.....	6
3.2. DELIVERY AND UNPACKING	6
3.3. IdentificaTION	6
3.4. LOCATION.....	7
3.5. FLOW DIRECTION.....	7
3.6. Assembly.....	8
3.7. INSPECTING AND CHECKING.....	8
3.8. WELDING.	9
3.9. AIR connectIOn TO actuaTor.....	10
4. Start-up	
4.1. single-seat VALVE applications.	11
4.2. sTART-UP.	11
4.3. OPERATION.....	11
5. Operating problems. Causes and solutions.	
6. Maintenance	
6.1. General information.....	13
6.2. Maintenance.	13
6.3. Cleaning	14
7. Assembly and disassembly	
7.1. DISASSEMBLY / ASSEMBLY OF THE SINGLE-SEAT VALVE (NL/NT TYPE)	15
7.2. DISASSEMBLY / ASSEMBLY OF THE SINGLE-SEAT VALVE (NL/NT TYPE)	16
7.3. DISASSEMBLY / ASSEMBLY OF THE SINGLE-SEAT VALVE (NLFI TYPE).....	17
7.4. DISASSEMBLY / ASSEMBLY OF THE SINGLE-SEAT VALVE (NLFM TYPE)	18
7.5. DISASSEMBLY / ASSEMBLY OF THE SINGLE-SEAT VALVE (K/M TYPE).....	19
7.6. DISASSEMBLY / ASSEMBLY OF THE MANUAL SINGLE-SEAT VALVE (K/M TYPE)	20
7.7. DISASSEMBLY / ASSEMBLY OF THE ACTUATOR.....	21
8. Technical specifications	
8.1 single-seat valve dimensions.....	23
8.2 manual-operation single-seat valve dimensions.....	24
8.3 section and parts list.	26

3. Receiving and installing

3.1. CHECK THE SHIPMENT

The first thing to do on receiving the valve is to verify that it matches the delivery note.

INOXPA will inspect all the equipment before packing, although it cannot guarantee that the merchandise will arrive intact to the user. For this reason, the valve received and any other article should be checked and, if it is found not to be in good condition and/or not all parts are included, the carrier should submit a report as soon as possible.

Each valve has a manufacturing number engraved. Indicate the manufacturing number in all documents and correspondence.

Series number →	VALVULAS NEUMATICAS / AIR OPERATED VALVES	
	Nº FIGURA: FIGURE NR:	TAMAÑO: SIZE:
	TIPO ACTUADOR: ACTUATOR TYPE:	

3.2. DELIVERY AND UNPACKING



INOXPA will not be responsible for the inappropriate unpacking of the valve and its components.

3.2.1. Delivery:

Check that all the parts indicated in the delivery slip are present

- Complete valve.
- Its components (if supplied).
- Delivery.
- Instructions manual.

3.2.2. Unpacking:

- Remove all traces of packing materials from the valve or parts.
- Inspect the valve or its constituent parts for possible damage caused during transport.
- Avoid any possible damage to the valve and its components.

3.3. IDENTIFICATION

N T 050 1 2 A E

MATERIAL JUNTAS / MATERIAL SEALS / MATERIAU JOINTS
E - EPDM
N - NBR
V - VITON

ACTUACIÓN / PERFORMANCE / EXECUTION
- válvula manual / handle / poignée
A - Cierra por muelle (NC) / Spring to close / Ferme par ressort
B - Abre por muelle (NO) / Spring to open / Ouvert par ressort
D - Doble efecto / Air-Air / Double effect

TAMAÑO ACTUADOR / ACTUATOR SIZE / TAILLE DE VERIN
1 - d.87 DN-25/40 3 - d.145. 65/80
2 - d.112 DN-50 4 - d.216. 100

CÓDIGO CONEXIONES / CODE CONNECTIONS / CODES DES CONNEXIONS
0 - Soldar DIN - pulgadas / Welding ends DIN - inches / A souder DIN - pouces
1 - Macho DIN / Male DIN / Bout fileté DIN
3 - Tuercas DIN - SMS / DIN - SMS Nut / Ecrou DIN - SMS
4 - Macho SMS / SMS Male / Bout fileté SMS
6 - Macho RJT / RJT Male / Bout fileté RJT
7 - Clamp / Ferrule Clamp / Clamp

DIÁMETRO NOMINAL / NOMINAL DIAMETER / DIAMETRE NOMINAL

DIN	025	040	050	065	080	100
Pulgadas	101	112	200	212	300	400

MONTAJE CUERPOS / HOUSING COMBINATIONS / MONTAGE DES CORPS

N N/M K

TIPO VÁLVULA / VALVE TYPE / TYPE DE VANNE
N/M - Válvula de cierre / Shut off / Soupape de fermeture
K - Válvula de cambio / Divers / Soupape d'échange



The buyer or user will be responsible for the assembly, installation, starting and operation of the valve.

3.4. LOCATION.

Place the valve in such a way as to facilitate inspections and checks. Leave sufficient space around the valve for appropriate inspection, separation and maintenance (See Section 3.8.1)

3.5. FLOW DIRECTION.

The recommended flow direction for the product passing through each of the valve types is indicated below. Following these indications will help to prevent as much as possible any pipe hammering and the consequences of this caused during single-seat valve closing operations. The recommended direction is always contrary to the valve closing movement, that is to say, the plug shaft always works against the fluid pressure when closing the valve.

For type N, M type valves, it is advisable to connect the fluid inlet to the valve at the lower opening.

For type-K divert valves, due to their design, it is advisable to connect the fluid inlet to the intermediate opening.

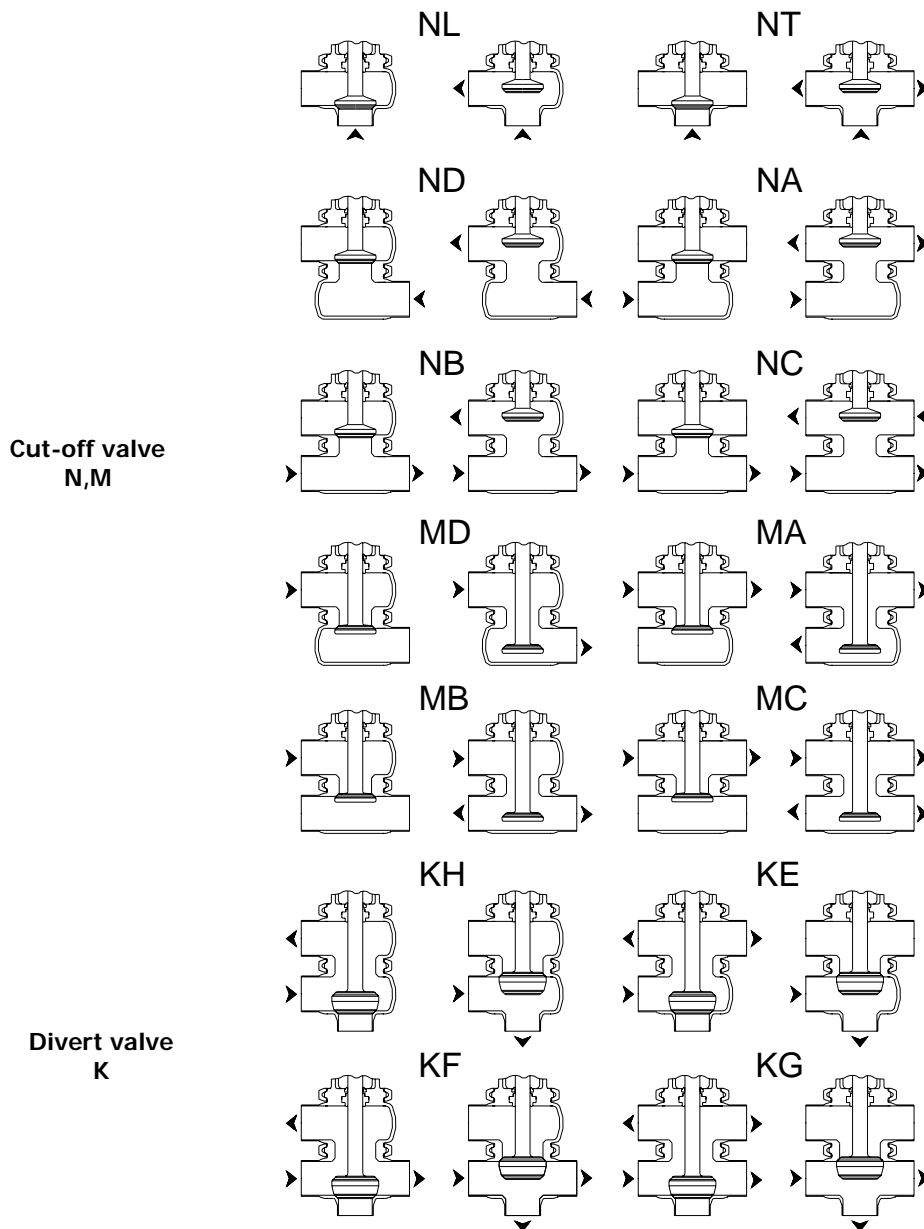

3.6. ASSEMBLY.

Once the location of the valve is defined, the pipe can be connected by welding the bodies of the valve or by means of accessories (connectors). In this case, do not forget the seals and to tighten the joints well.



In K, M, and N-type (two bodies) valves, it is advisable to use connection adapters to connect one of the bodies in order to facilitate disassembly of the valve.

Before welding the bodies to the piping, disassemble the valve to prevent damage to the joints.

Excessive stress should be avoided during the assembly of the valves and special attention should be given to the following:

- Vibration which may be produced in the installation.
- Expansion of the pipes during circulation of hot liquids.
- The weight that the pipes can withstand.
- Excessive intensity of welding.

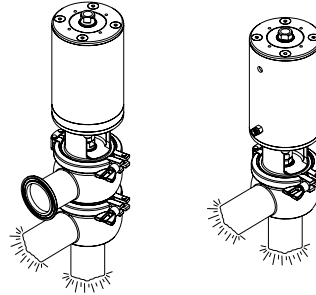

3.7. INSPECTING AND CHECKING.

Check the following before use:

- Check that the clamps and the nuts are well tightened.
- Open and close the valve (applying compressed air to the actuator or moving manually if a handle is available) several times to ensure that it operates correctly and check that the shaft seal fits smoothly with the valve body.

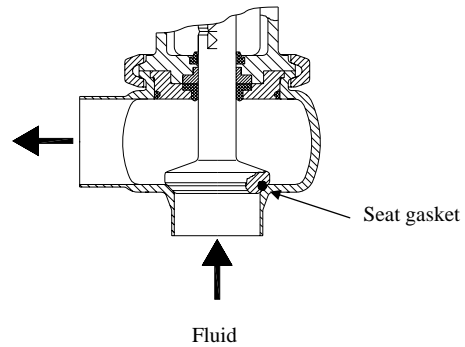

3.8. WELDING.



The welding work can only be carried out by persons qualified, trained and equipped with the necessary means to carry out this work.

Disassemble the valve before starting the welding work.

3.8.1. Weld / weld single-seat valve. Fig. N/K/M

- Disassemble the valve as indicated in section 7. *Assembly and disassembly*
- Weld the valve body to the pipes.
- When welding the valve body, it is very important to maintain the minimum distance (dimension A) enabling disassembly of the valve for later checks and replacement of valve parts (e.g. seals, springs). It is important to note the difference when the valve has a control head. (dimension B)
- In K-type valves, it is advisable to use connection adapters to connect one of the bodies in order to facilitate disassembly of the valve.

DN	A	B
25-1"	330	430
40-1 1/2"	350	450
50-2"	440	540
65 - 2 1/2"	510	610
80 - 3"	530	630
100-4"	585	685

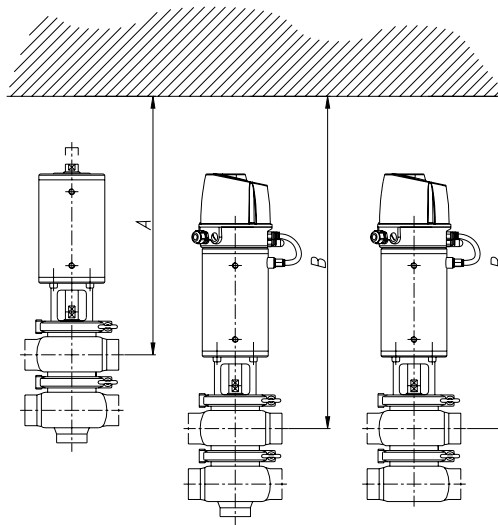

3.8.2. Weld tank bottom single-seat valve (NLFI / NLFM)

DN	Diam. d1	Diam. d2	h
25	155	150	3
40	155	150	3
50	165	160	3
65	195	190	3
80	215	210	3
100	255	250	3

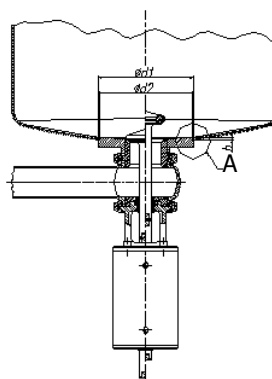
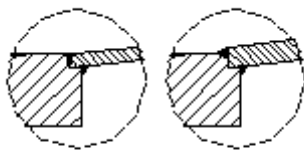

Fig. NLFI

Detail A: weld continues without cavities and homogeneous. It is preferable to act as it is indicated immediately afterwards:

Recommended



No recommended



3.9. AIR CONNECTION TO ACTUATOR.

- Connect and check the air connections as required; dual effect or single effect
- INOXPA valves are supplied with Ø6 tube connections and a silencer in S/E actuators.
- Mind the quality of the compressed air according to the specifications described in chapter 8 Technical Specifications.

Pneumatic connections R
1/8" (BSP) thread

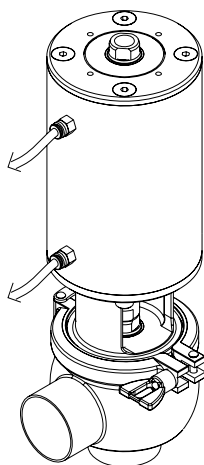

4. Start-up

The start-up of the valve can be carried out provided the instructions indicated in Chapter 3 – *Receiving and Installation* are followed.

This equipment is suitable for his use in food process.

4.1. SINGLE-SEAT VALVE APPLICATIONS.

Single-seat valves may be cut-off or change-over type. Cut-offs are used to open and close the passage of fluid, whereas change-overs are used to redirect the flow trajectory.

4.2. START-UP.



Before start-up, the responsible persons should be duly informed of the operation of the valve and the safety instructions to be followed. This instruction manual should be available to personnel at all times.

The following should be taken into consideration before starting-up the valve/actuator;

- Check that the pipe and valve are completely free from any traces of welding or other foreign matter. Carry out the cleaning of the system if required.
- Verify the smooth operation of the valve. If necessary, lubricate with special grease or soapy water.
- Check for possible leaks and check that all the pipes and connections are watertight and free from leaks.
- If the valve is supplied with actuator, ensure that the alignment of the valve shaft with the actuator shaft allows for a smooth operation.
- Check that the compressed air pressure at the intake to the actuator is that indicated in the Technical Specifications (*Chapter 8*).
- Mind the quality of the compressed air according to the specifications described in chapter 8 Technical Specifications.
- Operate the valve.

4.3. OPERATION.



Do not modify the operating parameters for which the valve has been designed without written prior authorisation from INOXPA.

Do not touch the moving parts of the coupling between the actuator and the valve when the actuator is connected to the compressed air.



Danger of burns! Do not touch the valve or pipes when hot liquids are circulating or when cleaning and/or sterilisation are being carried out.

5. Operating problems. Causes and solutions.

PROBLEM	CAUSE/EFFECT		SOLUTION
JERKING OF THE VALVE PLUG	The seal or bushing have worn out, deteriorated, or become blocked up.		<ul style="list-style-type: none"> • Replace the seals. • Replace the seals with others of different material and more appropriate to the product. • Lubricate with soapy water or lubricant compatible with the material of the seal and with the product.
	Insufficient air pressure		<ul style="list-style-type: none"> • Replace the actuator with a larger one. • Increase the compressed air pressure.
INTERNAL LEAK OF THE PRODUCT (VALVE CLOSED)	Normal wear of the seals		<ul style="list-style-type: none"> • Replace the seals.
	Premature wearing of the seals	Watertight seal worn or affected by the product. Excessive pressure in the line. Working temperature too high Loss of watertightness (vibration).	<ul style="list-style-type: none"> • Replace the seals with others of different material and more appropriate to the product. • Tighten any loose components. • Clean frequently.
	Backpressure		<ul style="list-style-type: none"> • Replace the actuator with a larger one.
VALVE DOES NOT OPEN/CLOSE	Deformation of seals. Actuator bush in poor condition and/or jammed (dirtiness) Excessive pressure on plug		<ul style="list-style-type: none"> • Replace the seals with others of different quality, if prematurely deteriorated. • Replace bush (clean) • Reduce pressure.
SURGE	The flow direction is the same as closing-movement direction.		<ul style="list-style-type: none"> • Flow direction must be contrary to closing movement • Use auxiliary air on the bush side.

6. Maintenance

6.1. GENERAL INFORMATION

This valve, just like any other machine, requires maintenance. The instructions contained in this manual cover the identification and replacement of spare parts. The instructions have been prepared for maintenance personnel and for those responsible for the supply of spare parts.



Carefully read Chapter 8. *Technical specifications*.

All replaced material should be duly eliminated/recycled according to the directives in effect in the area.

Assembly and disassembly of the valves must only be carried out by qualified staff.

Before starting on maintenance work, ensure that the tubes are not pressurised.

6.2. MAINTENANCE.

The following is recommended for appropriate maintenance:

- Regular inspection of the valve and its components..
- Keep a record of the operation of each valve, noting any incidents.
- Always have spare seals in stock.

During maintenance, pay particular attention to the danger indications indicated in this manual.



The valve and pipes should never be pressurised during maintenance.

The valve should never be hot during maintenance. Danger of burns!

6.2.1. Maintenance of the gaskets.

REPLACEMENT OF GASKETS	
Preventive maintenance	Replace after twelve (12) months.
Maintenance after a leak	Replace at the end of the process.
Scheduled maintenance	Regularly check that there are no leaks and that the valve is operating smoothly. Keep a record of the valve. Use statistics to plan inspections.
Lubrication	During assembly, apply lubricants compatible with the seal material. See the following table.

GASKET COMPONENT	LUBRICANT	Class NLGI DIN 51818
NBR/ FPM	Klübersynth UH 1 64-2403	3
EPDM/ NBR/ FPM	PARALIQ GTE 703	3

The time interval between each preventive maintenance may vary according to the working conditions to which the valve is submitted: Temperature, pressure, number of operations per day, type of cleaning solutions used, etc.

6.2.2. Storage.

Storage of the valves should be carried out in an enclosed area, under the following conditions:

Temperature from 15°C to 30°C

Relative humidity <60%

Open-air storage of the equipment is NOT allowed.

6.2.3. Spare parts

To request spare parts, it is necessary to indicate the type of valve, the position and the description of the part which can be found in the *Technical specifications* chapter.

6.3. CLEANING



The use of aggressive cleaning products such as caustic soda and nitric acid may cause burns to the skin.

Use rubber gloves during the cleaning process.



Always use protective goggles.

6.3.1. Automatic CIP (cleaning-in-place)

If the valve is installed in a system provided with the CIP process, its disassembly will not be required.

Cleaning solutions for CIP processes.

Only use clear water (chlorine-free) to mix with the cleaning agents:

a) Alkaline solution: 1% by weight of caustic soda (NaOH) at 70°C (150°F)

1 Kg NaOH + 100 l. of water = cleaning solution

or

2.2 l. NaOH at 33% + 100 l. of water = cleaning solution

b) Acid solution: 0.5% by weight of nitric acid (HNO₃) at 70°C (150°F)

0.7 litres HNO₃ at 53% + 100 l. of water = cleaning



Check the concentration of cleaning solutions; it may cause the deterioration of the watertight seals of the valve.

To remove any remains of cleaning products, ALWAYS perform a final rinse with clean water on completion of the cleaning process.



Before beginning the disassembly and assembly work, clean the valve inside as well as outside.

6.3.2. Automatic SIP (sterilization-in-place)

The process of sterilization with steam is applied to all the equipment including the pigging.



Do NOT start the equipment during the process of sterilization with steam.
The parts/materials suffer no damage if the indications specified in this manual are observed.

No cold liquid can enter the equipment till the temperature of the equipment is lower than 60°C (140°F).

Maximum conditions during the SIP process with steam or overheated water

- | | | |
|----|-------------------|--|
| a) | Max. temperature: | 140°C / 284°F |
| b) | Max. time: | 30 min |
| c) | Cooling: | Sterile air or inert gas |
| d) | Materials: | EPDM / PTFE (recommended)
FPM / NBR / VMQ (not recommended) |

7. Assembly and disassembly



Proceed with caution. There is danger of personal injury.

Always disconnect the compressed air before starting valve disassembly.



Never disassemble the valve clamps directly without reading the instructions thoroughly.

Assembly and disassembly of the valves / actuator must only be carried out by qualified staff.

7.1. DISASSEMBLY / ASSEMBLY OF THE SINGLE-SEAT VALVE (NL/NT TYPE)

Disassembly

1. Apply compressed air to the actuator (10) in order to set the plug (08) in the open position. (NC valve only)
2. Disassemble the clamp (34) and remove the actuator (10) lantern (21) shaft (08) and body cap (12) assembly from the valve body.
3. Release the compressed air from the actuator.
4. Disassemble the plug (08) shaft of the actuator and remove the seat seal (20).
5. Disassemble the body cap (12) and its gaskets (20B and 05).
6. Remove the guide bushing (11).
7. Unscrew the Allen screws (23) of the lantern (21) and disassemble the scraper (60).

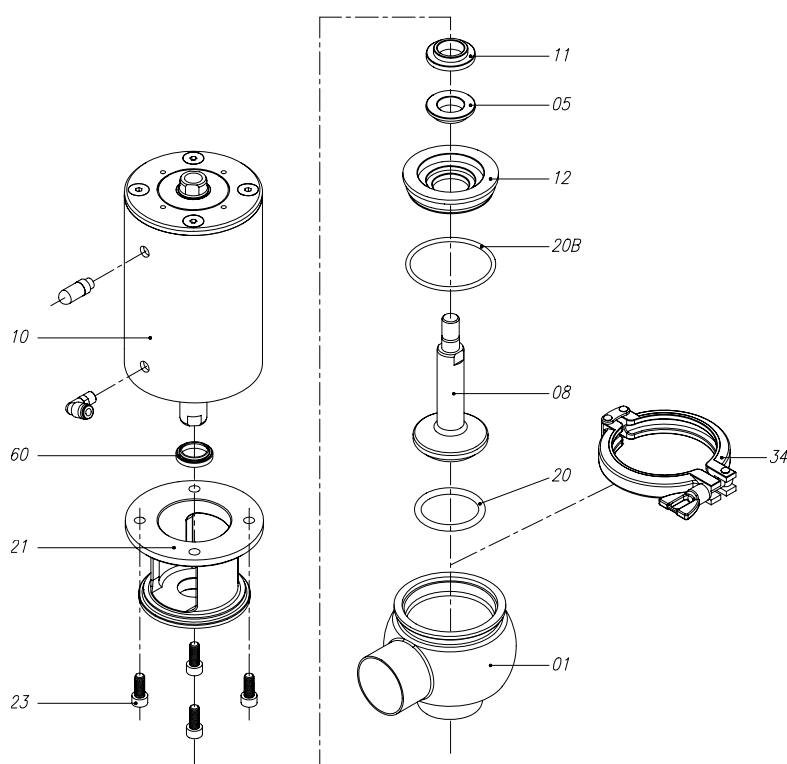

Assembly

1. Place the scraper (60) and guide bushing (11) in the lantern (21).
2. Place the lantern (21) underneath the actuator and screw in the four Allen screws (23).
3. Lubricate the gaskets with soapy water if necessary.
4. Fit the gaskets (20B and 05) on the body cap (12) and place this assembly on the lantern.
5. Connect the plug shaft (08) to the actuator (10).
6. Apply compressed air to the actuator (10) in order to set the plug (08) in the open position. (NC valve only)
7. Assemble the actuator (10) lantern (21) shaft (08) and body cap (12) assembly on the valve body (01) (360° rotatable according to users' needs), and tighten it using the clamp (34).
8. Release the compressed air from the actuator



The following tools are required to disassemble the valve:

- 5mm (DN-25/40), 6mm (DN-50/80), and 10mm (ND-100) Allen keys.
- Two 19mm fixed wrenches



Proceed with caution. There is danger of personal injury.

Never disassemble the valve clamps directly without reading the instructions thoroughly.



Assembly and disassembly of the valves / actuator must only be carried out by qualified staff.

7.2. DISASSEMBLY / ASSEMBLY OF THE SINGLE-SEAT VALVE (NL/NT TYPE)

Disassembly

1. Operate the handle (04) in order to set the plug shaft (08) in the open position.
2. Disassemble the clamp (34) and remove the handle (04) shaft (08) body cap (12) assembly from the body (01)
3. Disassemble the plug shaft (08) from the handle by loosening the upper nut (26B) and the hexagonal nut (26).
4. Remove the seal (20).
5. Disassemble the body cap (12) and its gaskets (20B and 05).
6. Remove the guide bushing (11) from the handle support (21).
7. Unscrew the handle (04) and the lock nut (26A) from the support (21)

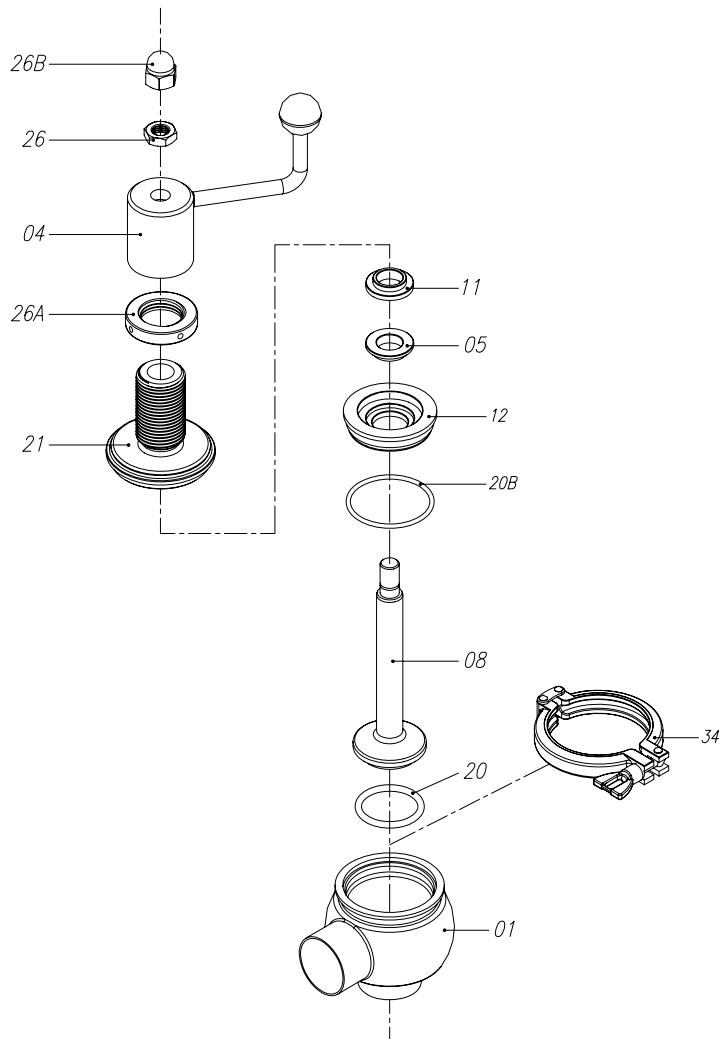

Assembly

1. Place the lock nut (26A) and the handle (04) on the support (21).
2. Place the guide bushing (11) on the support (21).
3. Fit the gaskets (20B and 05) on the body cap (12) and place this assembly on the support (21).
4. Lubricate the gaskets with soapy water if necessary.
5. Connect the plug shaft (08) using the blind nut (26B) and the nut (26).
6. Operate the handle (04) in order to set the plug shaft (08) in the open position.
7. Assemble the handle (04) shaft (08) body cap (12) assembly on the valve body (01) (360° rotatable according to users' needs), and tighten it using the clamp (34).



The following tools are required to disassemble the valve:

- 5mm (DN-25/40), 6mm (DN-50/80), and 10mm (ND-100) Allen keys.
- Two 19mm fixed wrenches



Proceed with caution. There is danger of personal injury.

Always disconnect the compressed air before starting valve disassembly.



Never disassemble the valve clamps directly without reading the instructions thoroughly.

Assembly and disassembly of the valves / actuator must only be carried out by qualified staff.

7.3. DISASSEMBLY / ASSEMBLY OF THE SINGLE-SEAT VALVE (NLF1 TYPE)

Disassembly

- 1 Operate the handle (04) in order to set the plug shaft (08) in the open position.
- 2 Disassemble the clamp (34) and remove the handle (04) shaft (08) body cap (12) assembly from the body (01).
- 3 Disassemble the plug shaft (08) from the handle by loosening the upper nut (26B) and the hexagonal nut (26).
- 4 Remove the seal (20).
- 5 Disassemble the body cap (12) and its gaskets (20B and 05).
- 6 Remove the guide bushing (11) from the handle support (21).
- 7 Unscrew the handle (04) and the lock nut (26A) from the support (21).

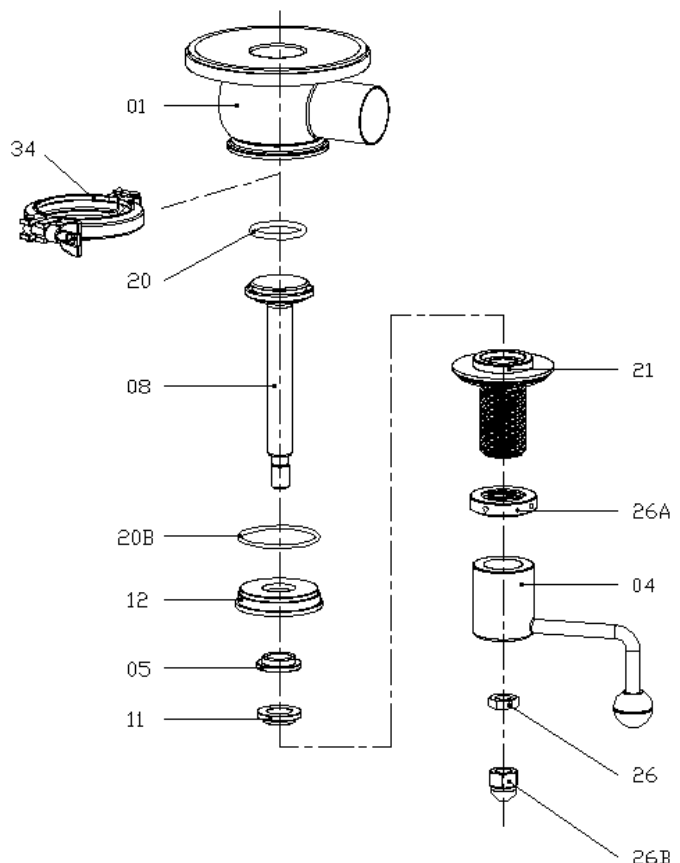

Assembly

- 1 Place the lock nut (26A) and the handle (04) on the support (21).
- 2 Place the guide bushing (11) on the support (21).
- 3 Fit the gaskets (20B and 05) on the body cap (12) and place this assembly on the support (21).
- 4 Lubricate the gaskets with soapy water if necessary.
- 5 Connect the plug shaft (08) using the blind nut (26B) and the nut (26).
- 6 Operate the handle (04) in order to set the plug shaft (08) in the open position.
- 7 Assemble the handle (04) shaft (08) body cap (12) assembly on the valve body (01) (360° rotatable according to users' needs), and tighten it using the clamp (34).



The following tools are required to disassemble the valve:

- 5mm (DN-25/40), 6mm (DN-50/80), and 10mm (ND-100) Allen keys.
- Two 19mm fixed wrenches



Proceed with caution. There is danger of personal injury.

Always disconnect the compressed air before starting valve disassembly.



Never disassemble the valve clamps directly without reading the instructions thoroughly.

Assembly and disassembly of the valves / actuator must only be carried out by qualified staff.

7.4. DISASSEMBLY / ASSEMBLY OF THE SINGLE-SEAT VALVE (NLFM TYPE)

Disassembly

1. Operate the handle (04) in order to set the plug shaft (08) in the open position.
2. Disassemble the plug shaft (08) from the handle by loosening the upper nut (26B) and the hexagonal nut (26).
3. Remove the seal (20).
4. Disassemble the clamp (34) and remove the handle (04) body cap (12) assembly from the body (01).
5. Disassemble the body cap (12) and its gaskets (20B and 05).
6. Disassemble the second clamp (34) and remove the flange (02).
7. Disassemble the separator (42) and its gaskets (20B).
8. Remove the guide bushing (11) from the handle support (21).
9. Unscrew the handle (04) and the lock nut (26A) from the support (21).

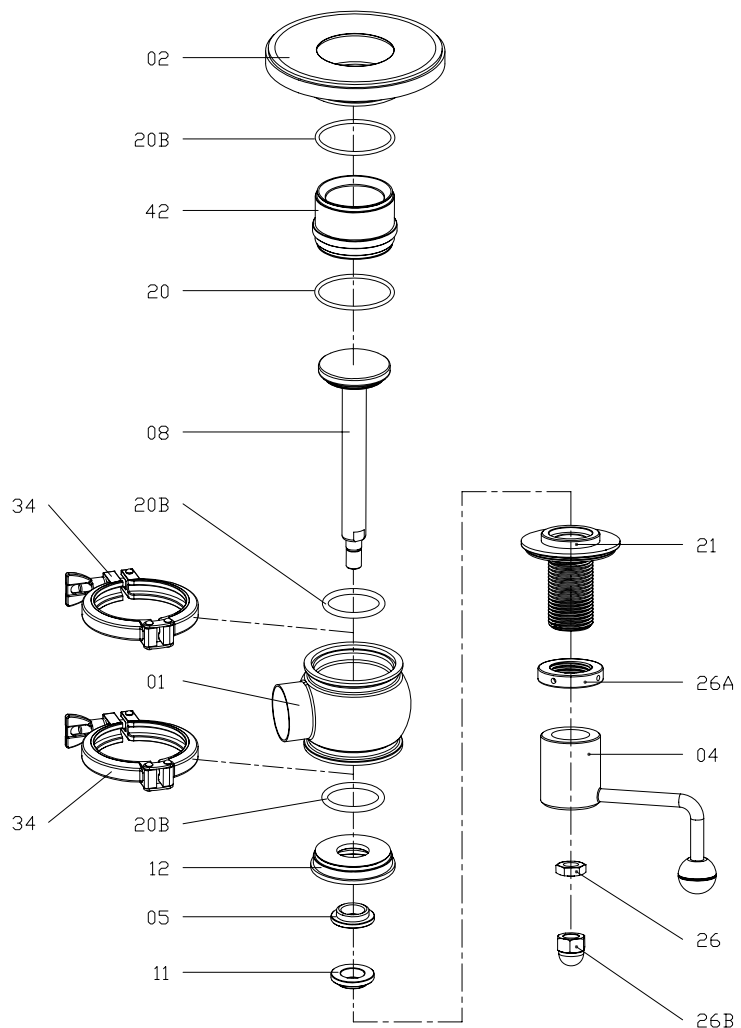

Assembly

1. Place the lock nut (26A) and the handle (04) on the support (21).
2. Place the guide bushing (11) on the support (21).
3. Fit the gaskets (20B and 05) on the body cap (12) and place this assembly on the support (21).
4. Lubricate the gaskets with soapy water if necessary.
5. Put the valve body (01) (360° rotatable according to users' needs), and tighten it using the clamp (34).
6. Fit the separator (42) with the gaskets (20B) on the flange (02).
7. Fit the flange (42) on the valve body (01), and tighten it using the clamp (34).
8. Fit the seal (20) on the shaft (08).
9. Connect the plug shaft (08) using the blind nut (26B) and the nut (26).
10. Operate the handle (04) in order to set the plug shaft (08) in the open position.



The following tools are required to disassemble the valve:

- 5mm (DN-25/40), 6mm (DN-50/80), and 10mm (ND-100) Allen keys.
- Two 19mm fixed wrenches



Proceed with caution. There is danger of personal injury.

Always disconnect the compressed air before starting valve disassembly.



Never disassemble the valve clamps directly without reading the instructions thoroughly.

Assembly and disassembly of the valves / actuator must only be carried out by qualified staff.

7.5. DISASSEMBLY / ASSEMBLY OF THE SINGLE-SEAT VALVE (K/M TYPE)

Disassembly

1. Apply compressed air to the actuator (10) in order to set the plug (08) in the open position. (NC valve only)
2. Disassemble the connection adapter from the upper body (01A)
3. Disassemble the lower clamp (34) and remove the actuator (10) lantern (21) shaft (08) separator (42) and body cap (12) assembly from the valve body.
4. Release the compressed air from the actuator.
5. Disassemble the plug (08) shaft of the actuator and remove the seat seal (20).
6. Disassemble the separator (42) and its gaskets (20B).
7. Disassemble the second clamp and remove the interchangeable body (01A).
8. Disassemble the body cap (12) and its gaskets (20B and 05).
9. Remove the guide bushing (11).
10. Unscrew the Allen screws (23) of the lantern (21) and disassemble the scraper (60).

Assembly

1. Place the scraper (60) and guide bushing (11) in the lantern (21).
2. Place the lantern (21) underneath the actuator and screw in the four Allen screws (23).
3. Lubricate the gaskets with soapy water if necessary.
4. Fit the gaskets (20B and 05) on the body cap (12) and place this assembly on the lantern.
5. Fit the interchangeable body (01A). (360° rotatable according to users' needs).
6. Assemble the separator (42) with its gaskets (20B) onto the body (01A).
7. Connect the plug shaft (08) and its seals (20 and 20A) to the actuator (10).
8. Apply compressed air to the actuator (10) in order to set the plug (08) in the open position. (NC valve only)
9. Assemble the actuator (10) lantern (21) shaft (08) and body cap (12) assembly on the valve body (01) (360° rotatable according to users' needs), and tighten it using the clamp (34).
10. Release the compressed air from the actuator.

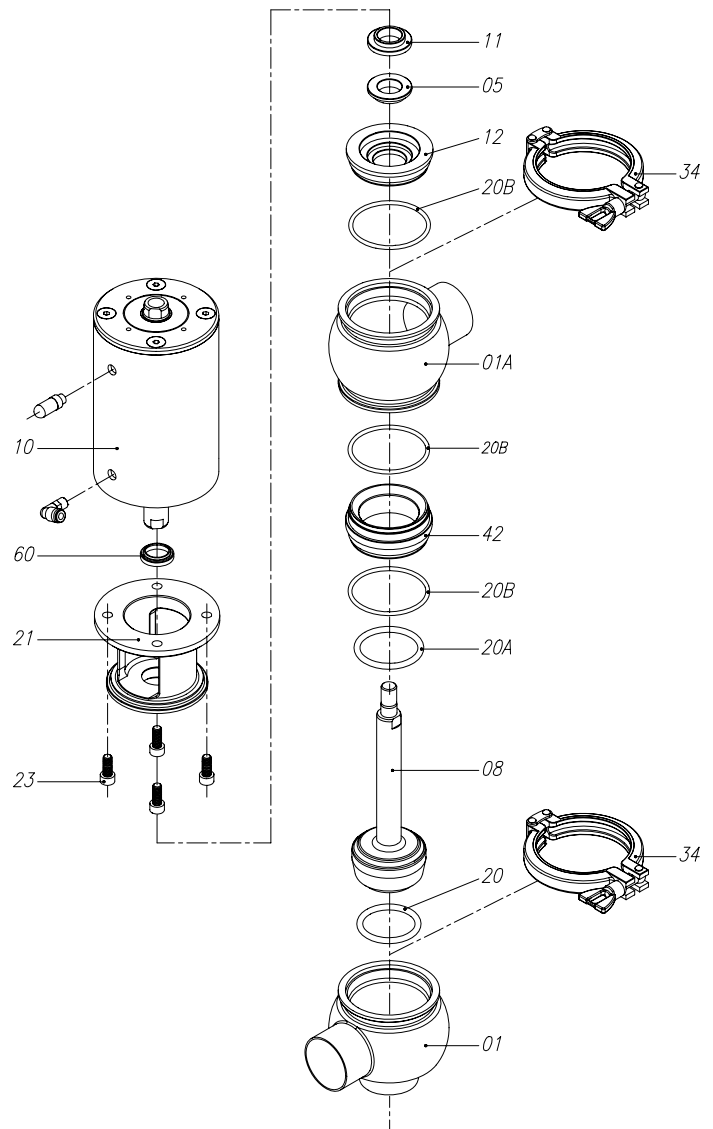

The following tools are required to disassemble the valve:

- 5mm (DN-25/40), 6mm (DN-50/80), and 10mm (ND-100) Allen keys.
- Two 19mm fixed wrenches



Proceed with caution. There is danger of personal injury.

Never disassemble the valve clamps directly without reading the instructions thoroughly.



Assembly and disassembly of the valves / actuator must only be carried out by qualified staff.

7.6. DISASSEMBLY / ASSEMBLY OF THE MANUAL SINGLE-SEAT VALVE (K/M TYPE)

Disassembly

1. Operate the handle (04) in order to set the plug shaft (08) in the open position.
2. Disassemble the clamp (34) and remove the handle (04) shaft (08) body cap (12) assembly from the body (01)
3. Disassemble the plug shaft (08) from the handle by loosening the upper nut (26B) and the hexagonal nut (26).
4. Remove the seal (20).
5. Disassemble the separator (42) and its gaskets (20B).
6. Disassemble the second clamp (34) and remove the interchangeable body (01A).
7. Disassemble the body cap (12) and its gaskets (20B and 05).
8. Remove the guide bushing (11) from the handle support (21).
9. Unscrew the handle (04) and the lock nut (26A) from the support (21).

Assembly

10. Place the lock nut (26A) and the handle (04) on the support (21).
11. Place the guide bushing (11) on the support (21).
12. Fit the gaskets (20B and 05) on the body cap (12) and place this assembly on the support (21).
13. Lubricate the gaskets with soapy water if necessary.
14. Fit the interchangeable body (01A). (360° rotatable according to users' needs).
15. Assemble the separator (42) with its gaskets (20B) onto the body (01A).
16. Connect the plug shaft (08) and its gaskets using the blind nut (26B) and the nut (26).
17. Operate the handle (04) in order to set the plug shaft (08) in the open position.
18. Assemble the handle (04) shaft (08) body cap (12) assembly on the valve body (01) (360° rotatable according to users' needs), and tighten it using the clamp (34).

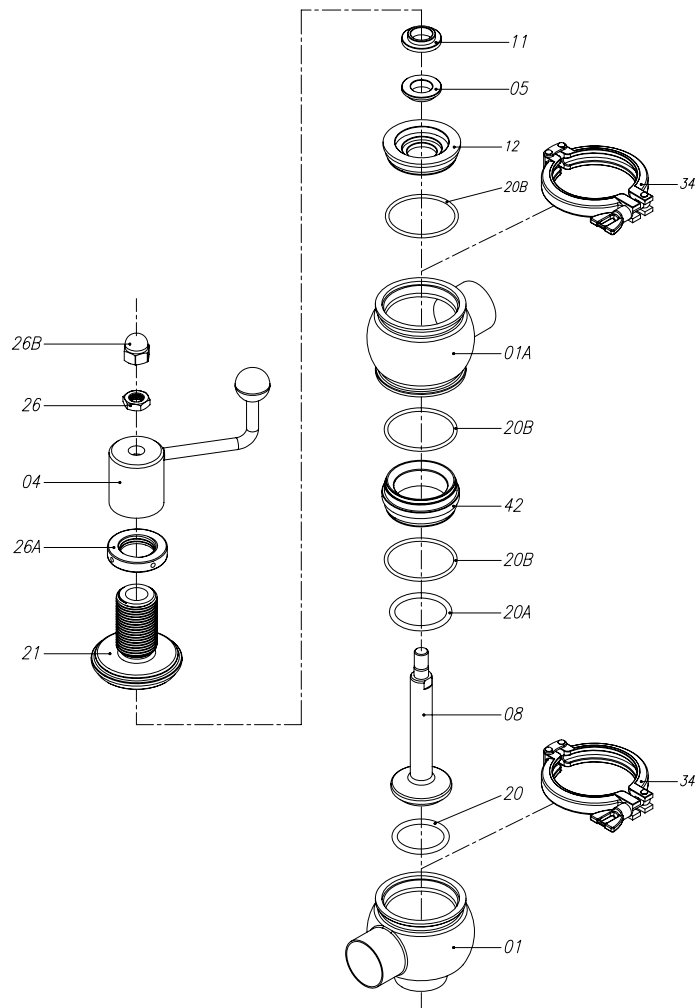

The following tools are required to disassemble the valve:

- Two 24mm fixed wrenches
- Two 19mm fixed wrenches



Proceed with caution. There is danger of personal injury.

Always disconnect the compressed air before starting valve disassembly.



Never disassemble the valve clamps directly without reading the instructions thoroughly.

Assembly and disassembly of the valves / actuator must only be carried out by qualified staff.

7.7. DISASSEMBLY / ASSEMBLY OF THE ACTUATOR.

Disassembly

1. Loosen the 4 screws (32) and remove the cap (39).
2. Place the actuator on the base of the press or in the lathe clamp. A thick tube and a shim must be used at the free end of the actuator.
3. Apply force to the shim. Once the cap (12) has lowered 15-20mm, remove the retention ring (45).
4. Reduce the force on the shim slowly, until the upper cap is free (note that the spring is no longer applying pressure).
5. Remove the cap (12) and the internal components, spring assembly (06), piston (30).
6. Remove the gaskets (20 and 20B) from the piston (30).
7. Remove the scraper (60), gasket (20B) and the guide (11) from the actuator base (12A) and the upper cap (12).

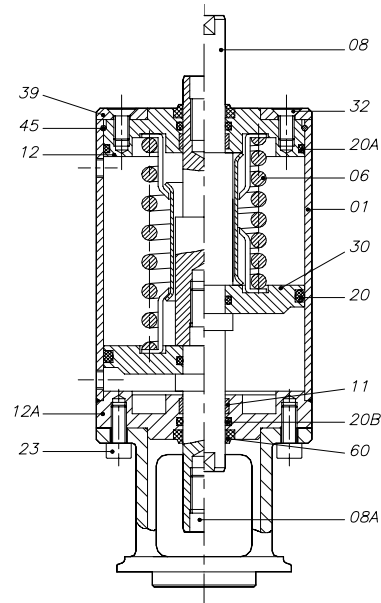

Assembly

1. Assemble the scraper (60), gasket (20B) and the guide (11) on the actuator base (12A) and the upper cap (12).
2. Place the gaskets (20 and 20B) on the piston (30).
3. Place the piston (30) and the spring assembly (06) in the cylinder (01).
4. Fit the upper cap (12) on the cylinder.
5. Apply force to the shim to lower it 15-20mm. Place the retention ring (45)
6. Place the cap (39) and screw in the 4 screws (32).
7. We apply compressed air to verify the correct operation of the actuator.
8. If the user needs an NO (normally open) valve, we will turn the actuator 180°.

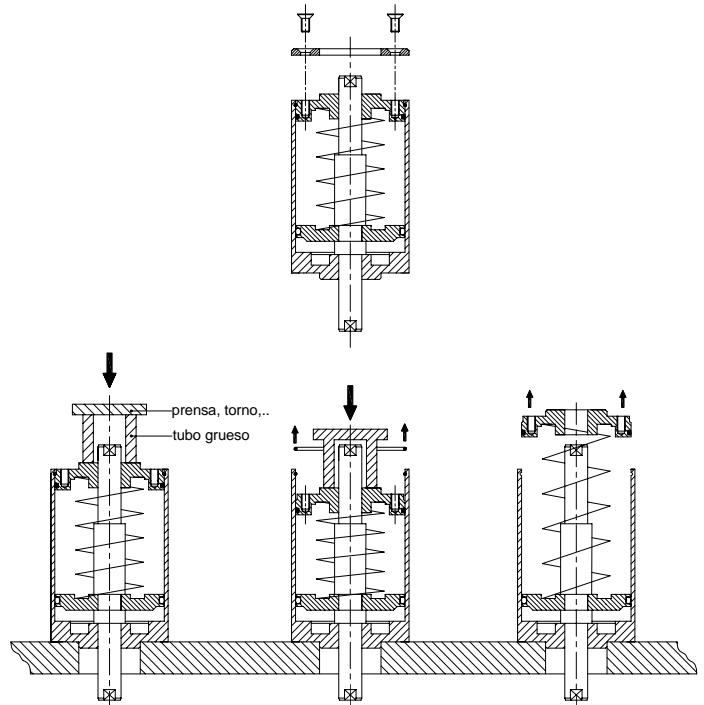

The following tools are required to disassemble the valve.

- 5mm (DN-25/40), 6mm (DN-50/80), and 10mm (ND-100) Allen keys.
- Screwdriver (to remove the retention ring).
- Press or lathe (to compress the spring and open the actuator).

8. Technical specifications

VALVE GENERAL DATA			
Maximum working pressure	DN-25 / 100 DN-1"/4"	10 bar	
Minimum working pressure	Vacuum		
Maximum working temperature	121°C (250°F) EPDM standard seals (Other qualities of seals will be adapted for higher temperatures)		
Compressed air pressure	6-8 bar		
Air compressed quality	According to DIN/ISO 8573.1 <ul style="list-style-type: none"> ○ <u>Solid particle content</u>: Quality class 3 / Particle size max. 5 micres / Particle density max. 5 mg/m³ ○ <u>Water content</u>: Quality class 4 / max. Dew point +2°C If the valve is used at higher altitudes or at low ambient temperatures, the dew point must be adapted accordingly ○ <u>Oil content</u>: Quality class 5, preferably oil free / max. 25 mg oil in 1 m³ air 		
Compressed air connection	R1/8" (BSP)		
Compressed air consumption (litres/cycle)	DN	SE (Single Effect)	DE (Double effect)
	25	0,13	0,26
	40	0,13	0,26
	50	0,29	0,58
	65	0,5	1
	80	0,5	1
	100	1,5	3

VALVE MATERIALS

Parts in contact with the product	AISI 316L (1.4404)
Other steel parts	AISI 304 (1.4301)
Seals in contact with the product	EPDM (Standard) - NBR - VITON
Surface finish	In contact with the product: Ra ≤ 0.8 µm External surfaces: Machined finish (turned on lathe)
Type of connections	DIN 11851 (Standard) Welding, FIL-IDF, BS-RJT, SMS, Clamp, Flanges, Macon.

8.1 SINGLE-SEAT VALVE DIMENSIONS.

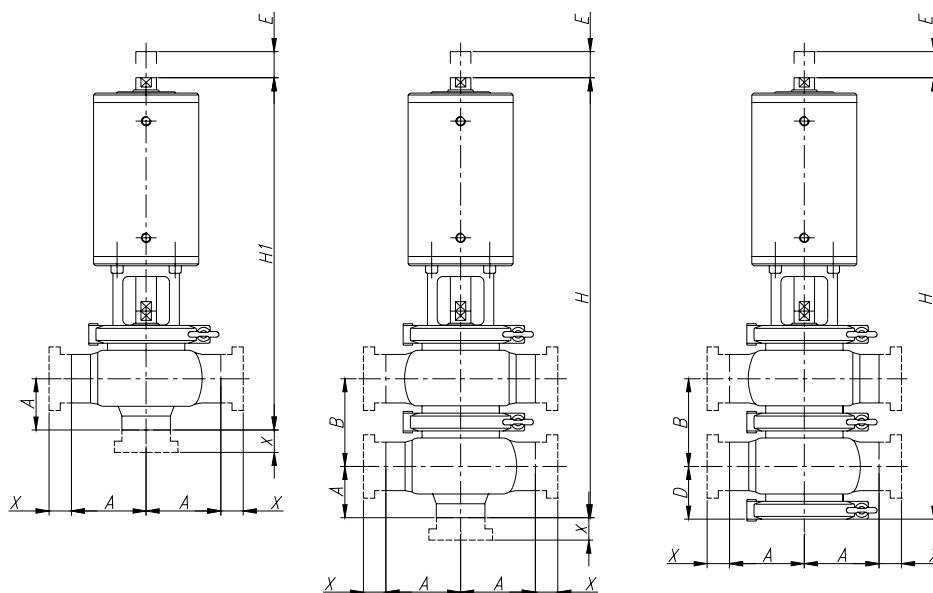

S/S Fig.

NL/NT

KH/KE/KF/KG

MD/MA/MB/MC – ND/NA/NB/NC

DN	A	C	D	E	H	H1	X		
							Macho-Male DIN	Tuerca-Nut DIN	Clamp DIN
25	50	56	35	22	330	274	22	15	21,5
40	60	68	41	22	356	288	22	15	
50	70	84	49	32	442	359	23	16	
65	80	100	57	36	522	422	25	17	28
80	90	115	65	36	555	440	25	17	
100	125	138	79	36	620	482	30	20	

DN	A	C	D	E	H	H1	X		
							Macho-Male SMS	Tuerca-Nut SMS	Clamp OD
1"	50	56	35	22	330	274	19	15	13
1½"	60	68	41	22	356	288	23	20	
2"	70	84	49	32	442	359	23	20	
2½"	80	100	57	36	522	422	27	24	
3"	90	115	65	36	555	440	27	24	
4"	125	138	79	36	620	482	35	30	16

8.2 MANUAL-OPERATION SINGLE-SEAT VALVE DIMENSIONS

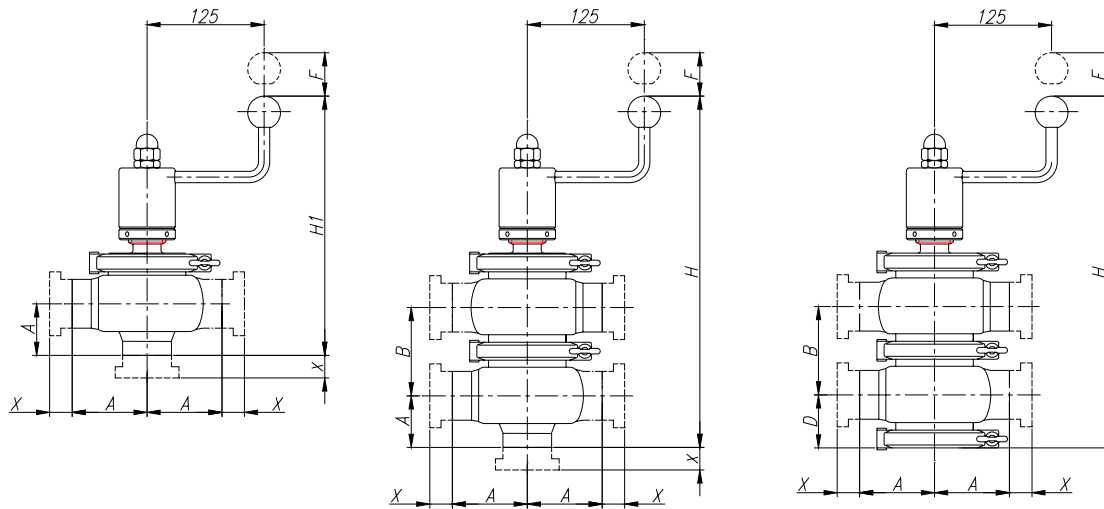

S/S Fig. NL/NT

KH/KE/KF/KG

MD/MA/MB/MC – ND/NA/NB/NC

DN	A	C	D	F	H	H1	X		
							Macho-Male DIN	Tuerca-Nut DIN	Clamp DIN
25	50	56	35	22	300	245	22	15	21,5
40	60	68	41	22	330	260	22	15	
50	70	84	49	32	355	275	23	16	
65	80	100	57	36	395	295	25	17	28
80	90	115	65	36	430	315	25	17	
100	125	138	79	40	480	340	30	20	

DN	A	C	D	F	H	H1	X		
							Macho-Male SMS	Tuerca-Nut SMS	Clamp OD
1"	50	56	35	22	300	245	19	15	13
1½"	60	68	41	22	330	260	23	20	
2"	70	84	49	32	355	275	23	20	
2½"	80	100	57	36	395	295	27	24	
3"	90	115	65	36	430	315	27	24	
4"	125	138	79	40	480	340	35	30	16

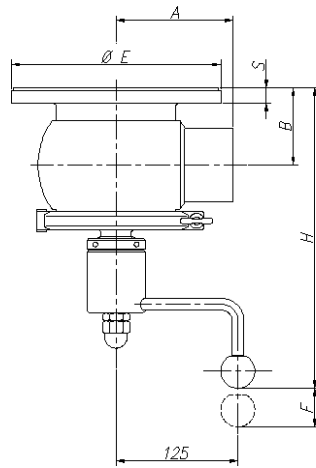

Welding Fig. NLFI

DN		A	B	F	E	S	H
25	1"	85	40	22	155	14	230
40	1½"	85	45	22	155	14	240
50	2"	90	50	32	165	14	245
65	2½"	110	65	36	195	16	270
80	3"	120	75	36	215	18	290

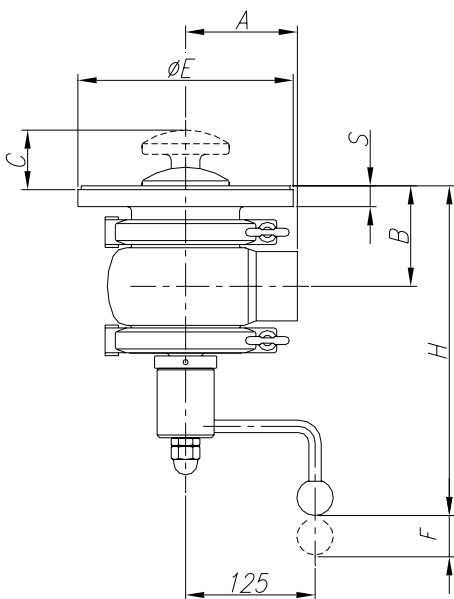

Welding Fig. NLFM

DN		A	B	C	F _{min}	E	S	H
25	1"	50	65	30	22	155	16	255
40	1½"	60	70	30	22	155	16	265
50	2"	70	80	45	32	165	16	275
65	2½"	80	90	50	36	195	16	295
80	3"	90	100	52	36	215	18	315
100	4"	125	120	62	40	255	20	340

8.3 SECTION AND PARTS LIST.

8.3.1 Section and parts list FIG. NL/NT PNEUMATIC OPERATION

- Fig. NL/NT Pneumatic Operation

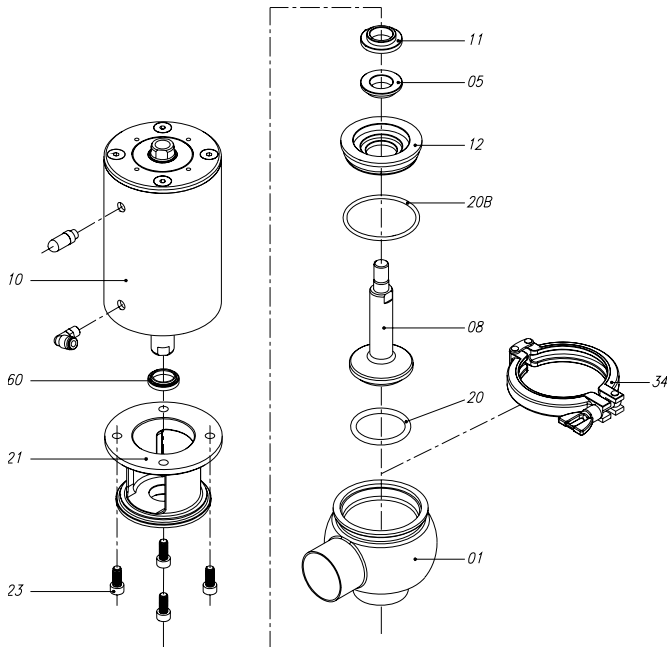

POSITION	DESIGNATION	MATERIAL	QUANTITY
01	Lower body L/T	AISI 316L	1
05	Shaft seal	EPDM	1
08	Valve shaft	AISI 316L	1
10	Actuator	AISI 304	1
11	Guide bushing	PTFE	1
12	Body cap	AISI 316L	1
20	O-ring	EPDM	1
20B	O-ring	EPDM	1
21	Lantern	AISI 304	1
23	DIN 912 Allen screw	A2	4
34	Clamp	AISI 304	1
60	Scraper	NBR	1

8.3.2 Parts list FIG. NL/NT PNEUMATIC OPERATION

POS	DESIGNATION	DN						
		25/1"	40/1½"	50/2"	65/2½"	80/3"	100/4"	
01	Valve body L	DIN	351262.6	351264.6	351265.6	351266.6	351267.6	351268.6
		Inches	351269.6	351270.6	351271.6	351272.6	351273.6	351274.6
	Valve body T	DIN	C-35042AT	C-35042CT	C-35042DT	C-35042ET	C-35042FT	C-35042GT
		Inches	C-35044AT	C-35044CT	C-35044DT	C-35044ET	C-35044FT	C-35044GT
05	Shaft seal	450811.E						
08	Valve shaft	350363.6	350364.6	350365.6	350366.6	350367.6	350368.6	
10	Actuator**	ACN1025S ACN1025D		ACN2050S ACN2050D	ACN3080S ACN3080D		ACN4100S ACN4100D	
11	Guide bushing	450888.I			450889.I			
12	Body cap	450890.6	450891.6	450892.6	450893.6	450894.6	450895.6	
20	O-ring	O4029553	O4037453	O4040653	O4059653	O4078753	O4097753	
20B	O-ring	O4040835	O4053535	O4066235	O4091635	O4098035	O4120235	
21	Lantern	350373.4	350374.4	350375.4	350376.4	350377.4	350378.4	
23	Allen screw	TA0616			TA0820		TA1225	
34	Clamp	1703200	1703212	1703300	173400	173412	1703600	
60	Scraper	RASOB2230NBR						

**Code ending in S or D (single or double effect).

8.3.3 Section and parts list FIG. NL/NT MANUAL OPERATION

• Fig. NL/NT Manual Operation

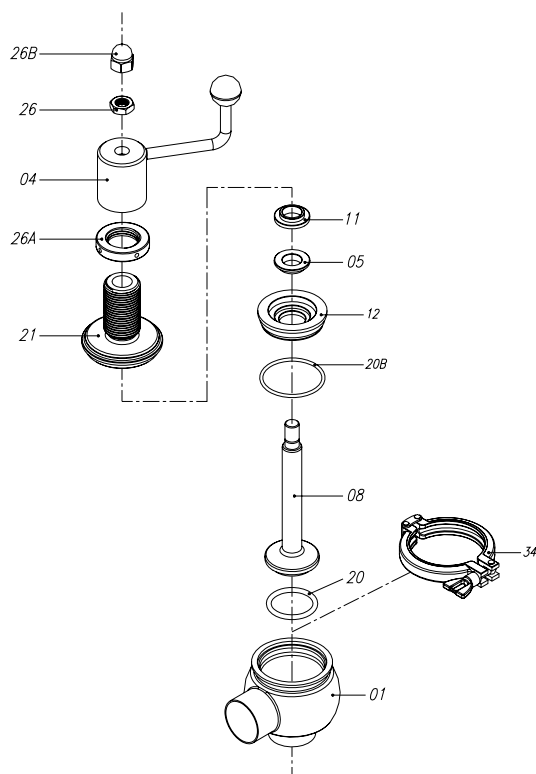

POSITIO N	DESIGNATION	MATERIAL	QUANTITY
01	Lower body L/T	AISI 316L	1
04	Handle	AISI 304	1
05	Shaft seal	EPDM	1
08	Valve shaft	AISI 316L	1
11	Guide bushing	PTFE	1
12	Body cap	AISI 316L	1
20	O-ring	EPDM	1
20B	O-ring	EPDM	1
21	Handle support	AISI 304	1
26	Hexagonal nut	AISI 304	1
26A	Lock Nut	AISI 304	1
26B	Cap nut	AISI 304	1
34	Clamp	AISI 304	1

8.3.4 Parts list FIG. NL/NT MANUAL OPERATION

POS	DESIGNATION	DN						
		25/1"	40/1 1/2"	50/2"	65/2 1/2"	80/3"	100/4"	
01	Valve body L	DIN	351262.6	351264.6	351265.6	351266.6	351267.6	351268.6
		Inches	351269.6	351270.6	351271.6	351272.6	351273.6	351274.6
	Valve body T	DIN	C-35042AT	C-35042CT	C-35042DT	C-35042ET	C-35042FT	C-35042GT
		Inches	C-35044AT	C-35044CT	C-35044DT	C-35044ET	C-35044FT	C-35044GT
04	Handle	C-45055A			C-45055B			
05	Shaft seal	450811.E						
08	Valve shaft	350613.6	350614.6	350615.6	350616.6	350617.6	350618.6	
11	Guide bushing	450888.I			450889.I			
12	Body cap	450890.6	450891.6	450892.6	450893.6	450894.6	450895.6	
20	O-ring	O4029553	O4037453	O4040653	O4059653	O4078753	O4097753	
20B	O-ring	O4040835	O4053535	O4066235	O4091635	O4098035	O4120235	
21	Support	350373.4	350374.4	350375.4	350376.4	350377.4	350378.4	
26	Hexagonal nut	TU5012			TU5016			
26A	Lock Nut	451271.4						
26B	Cap nut	TU4012			TU4016			
34	Clamp	1703200	1703212	1703300	173400	173412	1703600	

8.3.5 Section and parts list FIG. NLFI MANUAL OPERATION

• Fig. NLFI Manual Operation

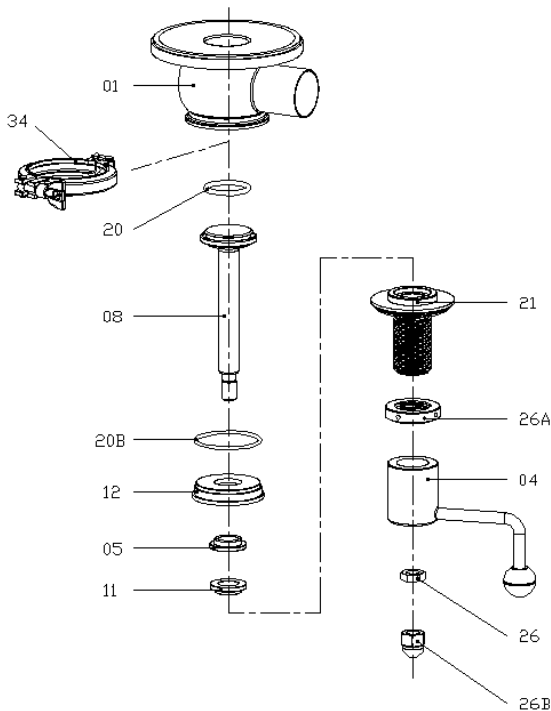

POSITION	DESIGNATION	MATERIAL	QUANTITY
01	Lower body L/T	AISI 316L	1
04	Handle	AISI 304	1
05	Shaft seal	EPDM	1
08	Valve shaft	AISI 316L	1
11	Guide bushing	PTFE	1
12	Body cap	AISI 316L	1
20	O-ring	EPDM	1
20B	O-ring	EPDM	1
21	Handle support	AISI 304	1
26	Hexagonal nut	AISI 304	1
26A	Lock nut	AISI 304	1
26B	Cap nut	AISI 304	1
34	Clamp	AISI 304	1

8.3.6 Section and parts list FIG. NLFM MANUAL OPERATION

• Fig. NLFM Manual Operation

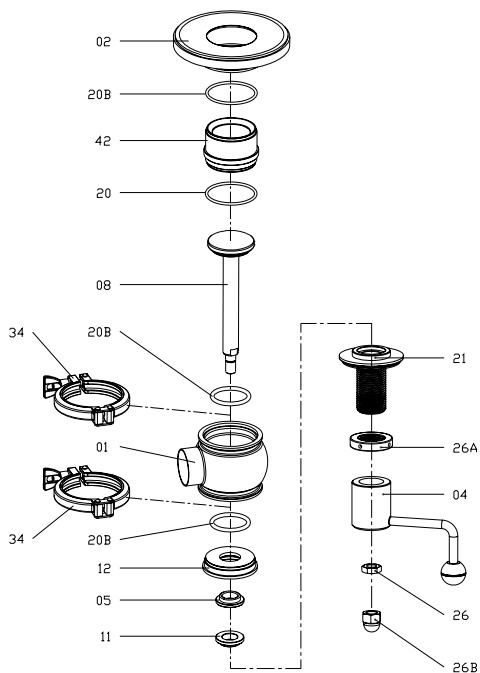

POSITION	DESIGNATION	MATERIAL	QUANTITY
01	Lower body L/T	AISI 316L	1
02	Flange	AISI 316L	1
04	Handle	AISI 304	1
05	Shaft seal	EPDM	1
08	Valve shaft	AISI 316L	1
11	Guide bushing	PTFE	1
12	Body cap	AISI 316L	1
20	O-ring	EPDM	1
20B	O-ring	EPDM	3
21	Handle support	AISI 304	1
26	Hexagonal nut	AISI 304	1
26A	Lock nut	AISI 304	1
26B	Cap nut	AISI 304	1
34	Clamp	AISI 304	2
42	Separator	AISI 316L	1

8.3.7 Section and parts list FIG. KH/KE/KF/KG PNEUMATIC OPERATION

• Fig. KE/KF/KG/KH Pneumatic Operation

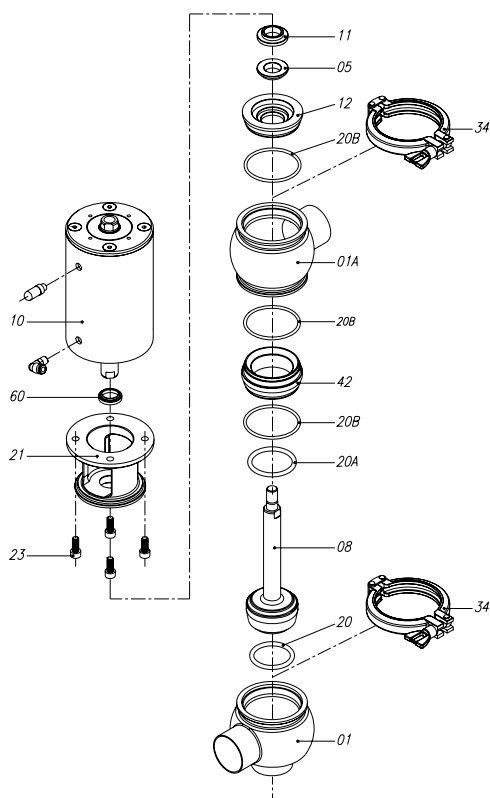

POSITION	DESIGNATION	MATERIAL	QUANTITY
01	Lower body L/T	AISI 316L	1
01A	Upper body L/T	AISI 316L	1
05	Shaft seal	EPDM	1
08	Valve shaft	AISI 316L	1
10	Actuator	AISI 304	1
11	Guide bushing	PTFE	1
12	Body cap	AISI 316L	1
20	O-ring	EPDM	1
20A	O-ring	EPDM	1
20B	O-ring	EPDM	3
21	Lantern	AISI 304	1
23	DIN 912 Allen screw	A2	4
34	Clamp	AISI 304	2
42	Separator	AISI 316L	1
60	Scraper	NBR	1

8.3.8 Parts list FIG. KH/KE/KF/KG PNEUMATIC OPERATION

POS	DESIGNATION		DN					
			25/1"	40/1½"	50/2"	65/2½"	80/3"	100/4"
01	Lower body L	DIN	351262.6	351264.6	351265.6	351266.6	351267.6	351268.6
		Inches	351269.6	351270.6	351271.6	351272.6	351273.6	351274.6
	Lower body T	DIN	C-35042AT	C-35042CT	C-35042DT	C-35042ET	C-35042FT	C-35042GT
		Inches	C-35044AT	C-35044CT	C-35044DT	C-35044ET	C-35044FT	C-35044GT
01A	Upper body L	DIN	351275.6	351277.6	351278.6	351279.6	351280.6	351281.6
		Inches	351282.6	351283.6	351284.6	351285.6	351286.6	351287.6
	Upper body T	DIN	C-35041AT	C-35041CT	C-35041DT	C-35041ET	C-35041FT	C-35041GT
		Inches	C-35043AT	C-35043CT	C-35043DT	C-35043ET	C-35043FT	C-35043GT
05	Shaft seal		450811.E					
08	Valve shaft		350369.6	350370.6	350371.6	350372.6	250022.6	250023.6
10	Actuator**		ACN1025S ACN1025D		ACN2050S ACN2050D	ACN3080S ACN3080D		ACN4100S ACN4100D
11	Guide bushing		450888.I			450889.I		
12	Body cap		450890.6	450891.6	450892.6	450893.6	450894.6	450895.6
20	O-ring		O4029553	O4037453	O4040653	O4059653	O4078753	O4097753
20A	O-ring		O4029553	O4037453	O4046953	O4066053	O4078753	O4097753
20B	O-ring		O4040835	O4053535	O4066235	O4091635	O4098035	O4120235
21	Lantern		350373.4	350374.4	350375.4	350376.4	350377.4	350378.4
23	Allen screw		TA0616			TA0820		
34	Clamp		1703200	1703212	1703300	173400	173412	1703600
42	Separator		450896.6	450897.6	450898.6	450899.6	450900.6	450901.6
60	Scraper		RASOB2230NBR					

**Code ending in S or D (single or double effect).

8.3.9 Section and parts list FIG. KH/KE/KF/KG MANUAL OPERATION

- Fig. KE/KF/KG/KH Manual Operating

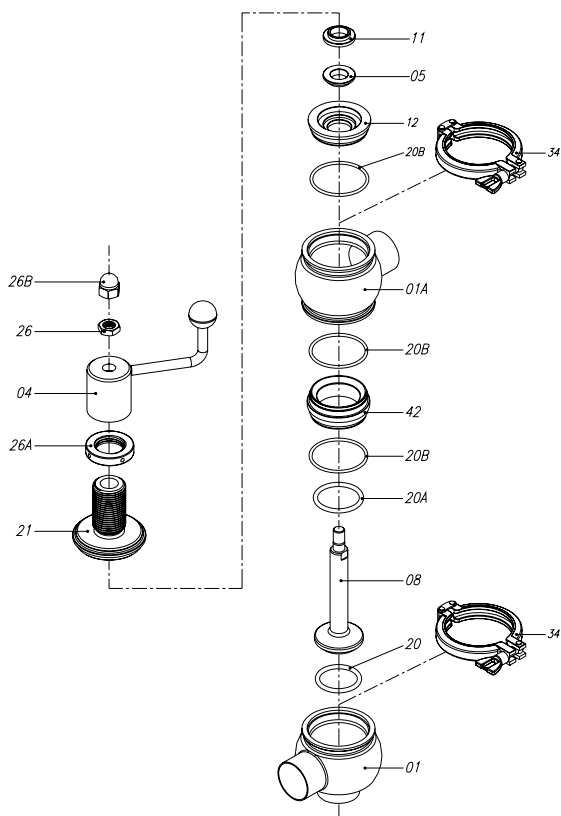

POSICIÓN	DESIGNACIÓN	MATERIAL	CANTIDAD
01	Lower body L/T	AISI 316L	1
01A	Upper body L/T	AISI 316L	1
04	Handle	AISI 304	1
05	Shaft seal	EPDM	1
08	Valve shaft	AISI 316L	1
11	Guide bushing	PTFE	1
12	Body cap	AISI 316L	1
20	O-ring	EPDM	1
20A	O-ring	EPDM	1
20B	O-ring	EPDM	3
21	Handle support	AISI 304	1
26	Hexagonal nut	AISI 304	1
26A	Lock Nut	AISI 304	1
26B	Cap nut	AISI 304	1
34	Clamp	AISI 304	2
42	Separator	AISI 316L	1

8.3.10 Parts list FIG. KH/KE/KF/KG MANUAL OPERATION

POS	DESIGNATION		DN					
			25/1"	40/1½"	50/2"	65/2½"	80/3"	100/4"
01	Lower body L	DIN	351262.6	351264.6	351265.6	351266.6	351267.6	351268.6
		Inches	351269.6	351270.6	351271.6	351272.6	351273.6	351274.6
01	Lower body T	DIN	C-35042AT	C-35042CT	C-35042DT	C-35042ET	C-35042FT	C-35042GT
		Inches	C-35044AT	C-35044CT	C-35044DT	C-35044ET	C-35044FT	C-35044GT
01A	Upper body L	DIN	351275.6	351277.6	351278.6	351279.6	351280.6	351281.6
		Inches	351282.6	351283.6	351284.6	351285.6	351286.6	351287.6
	Upper body T	DIN	C-35041AT	C-35041CT	C-35041DT	C-35041ET	C-35041FT	C-35041GT
		Inches	C-35043AT	C-35043CT	C-35043DT	C-35043ET	C-35043FT	C-35043GT
04	Handle	C-45055A			C-45055B			
05	Shaft seal	450811.E						
08	Valve shaft	350619.6	350620.6	350621.6	350622.6	250037.6	250038.6	
11	Guide bushing	450888.I			450889.I			
12	Body cap	450890.6	450891.6	450892.6	450893.6	450894.6	450895.6	
20	O-ring	O4029553	O4037453	O4040653	O4059653	O4078753	O4097753	
20A	O-ring	O4029553	O4037453	O4046953	O4066053	O4078753	O4097753	
20B	O-ring	O4040835	O4053535	O4066235	O4091635	O4098035	O4120235	
21	Handle support	350373.4	350374.4	350375.4	350376.4	350377.4	350378.4	
26	Hexagonal nut	TU5012			TU5016			
26A	Lock nut	451271.4						
26B	Blind nut	TU4012			TU4016			
34	Clamp	1703200	1703212	1703300	173400	173412	1703600	
42	Separator	450896.6	450897.6	450898.6	450899.6	450900.6	450901.6	

8.3.11 Section and parts list FIG. NA/NB/NC/ND PNEUMATIC OPERATION

• Fig. NA/NB/NC/ND Pneumatic Operating

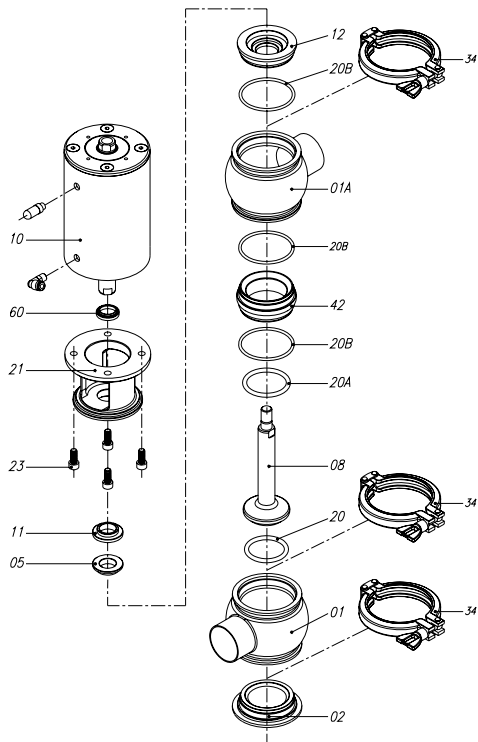

POSITION	DESIGNATION	MATERIAL	QUANTITY
01	Lower body L/T	AISI 316L	1
01A	Upper body L/T	AISI 316L	1
02	Blind lower opening	AISI 316L	1
05	Shaft seal	EPDM	1
08	Valve shaft	AISI 316L	1
10	Actuator	AISI 304	1
11	Guide bushing	PTFE	1
12	Body cap	AISI 316L	1
20	O-ring	EPDM	1
20A	O-ring	EPDM	1
20B	O-ring	EPDM	1
21	Lantern	AISI 304	1
23	DIN 912 Allen screw	A2	4
34	Clamp	AISI 304	3
42	Separator	AISI 316L	1
60	Scraper	NBR	1

8.3.12 Parts list FIG. NA/NB/NC/ND PNEUMATIC OPERATION

POS	DESIGNATION	DN						
		25/1"	40/1½"	50/2"	65/2½"	80/3"	100/4"	
01	Lower body L	DIN	351275.6	351277.6	351278.6	351279.6	351280.6	351281.6
		Inches	351282.6	351283.6	351284.6	351285.6	351286.6	351287.6
01A	Upper body L	DIN	351275.6	351277.6	351278.6	351279.6	351280.6	351281.6
		Inches	351282.6	351283.6	351284.6	351285.6	351286.6	351287.6
01/01A	Up/Low body T	DIN	C-35041AT	C-35041CT	C-35041DT	C-35041ET	C-35041FT	C-35041GT
		Inches	C-35043AT	C-35043CT	C-35043DT	C-35043ET	C-35043FT	C-35043GT
02	Lower opening	451657.6	451658.6	451659.6	451660.6	451661.6	451662.6	
05	Shaft seal	450811.E						
08	Valve shaft	350363.6	350364.6	350365.6	350366.6	350367.6	350368.6	
10	Actuator**	ACN1025S ACN1025D		ACN2050S ACN2050D	ACN3080S ACN3080D		ACN4100S ACN4100D	
11	Guide bushing	450888.I			450889.I			
12	Body cap	450890.6	450891.6	450892.6	450893.6	450894.6	450895.6	
20	O-ring	O4029553	O4037453	O4040653	O4059653	O4078753	O4097753	
20A	O-ring	O4029553	O4037453	O4046953	O4066053	O4078753	O4097753	
20B	O-ring	O4040835	O4053535	O4066235	O4091635	O4098035	O4120235	
21	Lantern	350373.4	350374.4	350375.4	350376.4	350377.4	350378.4	
23	Allen screw	TA0616		TA0820			TA1225	
34	Clamp	1703200	1703212	1703300	173400	173412	1703600	
42	Separator	450896.6	450897.6	450898.6	450899.6	450900.6	450901.6	
60	Scraper	RASOB2230NBR						

**Code ending in S or D (single or double effect).

8.3.13 Section and parts list FIG. NA/NB/NC/ND MANUAL OPERATION

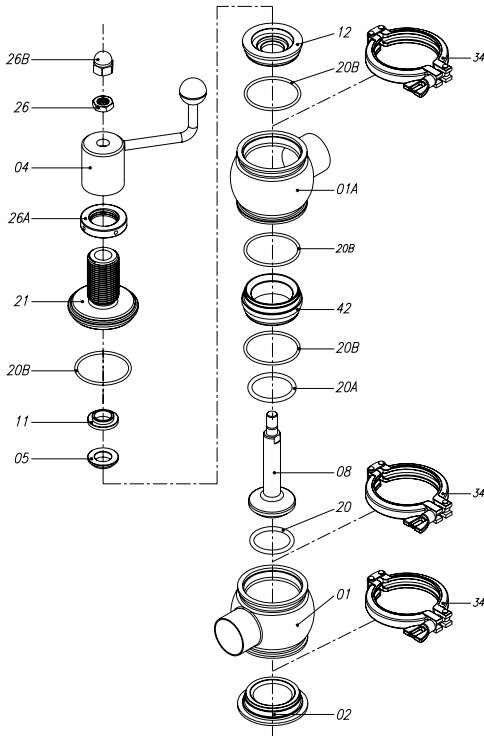

POSITION	DESIGNATION	MATERIAL	QUANTITY
01	Lower body L/T	AISI 316L	1
01A	Upper body L/T	AISI 316L	1
02	Blind lower opening	AISI 316L	1
04	Handle	AISI 304	1
05	Shaft seal	EPDM	1
08	Valve shaft	AISI 316L	1
11	Guide bushing	PTFE	1
12	Body cap	AISI 316L	1
20	O-ring	EPDM	1
20A	O-ring	EPDM	1
20B	O-ring	EPDM	3
21	Support	AISI 304	1
26	Hexagonal nut	AISI 304	1
26A	Lock nut	AISI 304	1
26B	Blind nut	AISI 304	1
34	Clamp	AISI 304	3
42	Separator	AISI 316L	1

Fig. NA/NB/NC/ND

8.3.14 Parts list FIG. NA/NB/NC/ND MANUAL OPERATION

POS	DESIGNATION	DN						
		25/1"	40/1½"	50/2"	65/2½"	80/3"	100/4"	
01	Lower body L	DIN	351275.6	351277.6	351278.6	351279.6	351280.6	351281.6
		Inches	351282.6	351283.6	351284.6	351285.6	351286.6	351287.6
01A	Upper body L	DIN	351275.6	351277.6	351278.6	351279.6	351280.6	351281.6
		Inches	351282.6	351283.6	351284.6	351285.6	351286.6	351287.6
01/01A	Up/Low body T	DIN	C-35041AT	C-35041CT	C-35041DT	C-35041ET	C-35041FT	C-35041GT
		Inches	C-35043AT	C-35043CT	C-35043DT	C-35043ET	C-35043FT	C-35043GT
02	Blind lower opening	451657.6	451658.6	451659.6	451660.6	451661.6	451662.6	
04	Handle	C-45055A			C-45055B			
05	Shaft seal	450811.E						
08	Valve shaft	350613.6	350614.6	350615.6	350616.6	350617.6	350618.6	
11	Guide bushing	450888.I			450889.I			
12	Body cap	450890.6	450891.6	450892.6	450893.6	450894.6	450895.6	
20	O-ring	O4029553	O4037453	O4040653	O4059653	O4078753	O4097753	
20B	O-ring	O4040835	O4053535	O4066235	O4091635	O4098035	O4120235	
21	Support	350373.4	350374.4	350375.4	350376.4	350377.4	350378.4	
26	Hexagonal nut	TU5012			TU5016			
26A	Lock nut	451271.4						
26B	Blind nut	TU4012			TU4016			
34	Clamp	1703200	1703212	1703300	173400	173412	1703600	
42	Separator	450896.6	450897.6	450898.6	450899.6	450900.6	450901.6	

8.3.15 Section and parts list FIG. MA/MB/MC/MD PNEUMATIC OPERATION

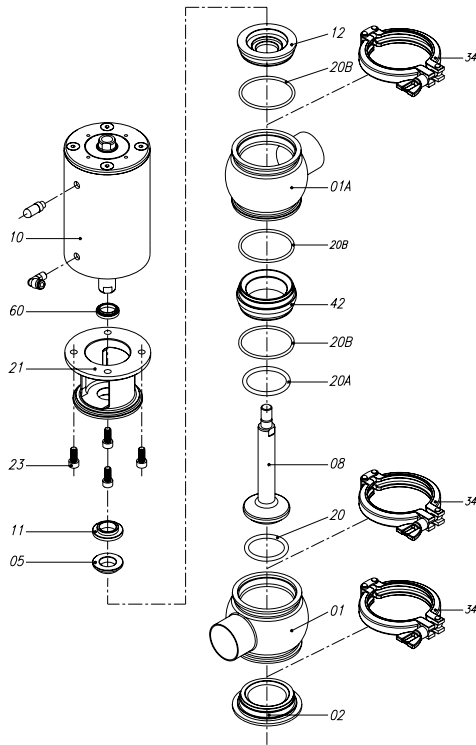

POSITION	DESIGNATION	MATERIAL	QUANTITY
01	Lower body L/T	AISI 316L	1
01A	Upper body L/T	AISI 316L	1
02	Blind lower opening	AISI 316L	1
05	Shaft seal	EPDM	1
08	Valve shaft	AISI 316L	1
10	Actuator	AISI 304	1
11	Guide bushing	PTFE	1
12	Body cap	AISI 316L	1
20	O-ring	EPDM	1
20A	O-ring	EPDM	1
20B	O-ring	EPDM	1
21	Lantern	AISI 304	1
23	DIN 912 Allen screw	A2	4
34	Clamp	AISI 304	3
42	Separator	AISI 316L	1
60	Scraper	NBR	1

Fig. NA/NB/NC/ND

8.3.16 Parts list FIG. MA/MB/MC/MD PNEUMATIC OPERATION

POS	DESIGNATION	DN						
		25/1"	40/1½"	50/2"	65/2½"	80/3"	100/4"	
01	Lower body L	DIN	351275.6	351277.6	351278.6	351279.6	351280.6	351281.6
		Inches	351282.6	351283.6	351284.6	351285.6	351286.6	351287.6
01A	Upper body L	DIN	351275.6	351277.6	351278.6	351279.6	351280.6	351281.6
		Inches	351282.6	351283.6	351284.6	351285.6	351286.6	351287.6
01/01A	Up/Low body T	DIN	C-35041AT	C-35041CT	C-35041DT	C-35041ET	C-35041FT	C-35041GT
		Inches	C-35043AT	C-35043CT	C-35043DT	C-35043ET	C-35043FT	C-35043GT
02	Blind lower opening	451657.6	451658.6	451659.6	451660.6	451661.6	451662.6	
05	Shaft seal	450811.E						
08	Valve shaft	350914.6	350915.6	350916.6	350917.6	250040.6	250041.6	
10	Actuator**	ACN1025S ACN1025D		ACN2050S ACN2050D	ACN3080S ACN3080D		ACN4100S ACN4100D	
11	Guide bushing	450888.I			450889.I			
12	Body cap	450890.6	450891.6	450892.6	450893.6	450894.6	450895.6	
20	O-ring	O4029553	O4037453	O4040653	O4059653	O4078753	O4097753	
20A	O-ring	O4029553	O4037453	O4046953	O4066053	O4078753	O4097753	
20B	O-ring	O4040835	O4053535	O4066235	O4091635	O4098035	O4120235	
21	Lantern	350373.4	350374.4	350375.4	350376.4	350377.4	350378.4	
23	Allen screw	TA0616			TA0820			TA1225
34	Clamp	1703200	1703212	1703300	173400	173412	1703600	
42	Separator	450896.6	450897.6	450898.6	450899.6	450900.6	450901.6	
60	Scraper	RASOB2230NBR						

**Code ending in S or D (single or double effect).

8.3.17 Section and parts list FIG. MA/MB/MC/MD MANUAL OPERATION

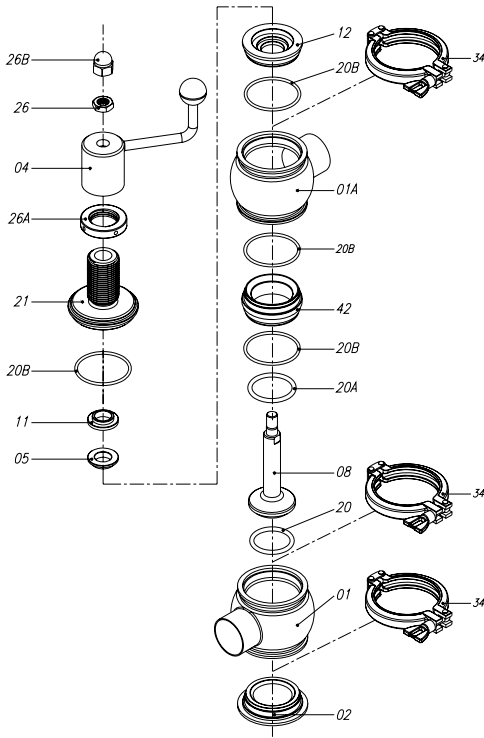

POSITION	DESIGNATION	MATERIAL	QUANTITY
01	Lower body L/T	AISI 316L	1
01A	Upper body L/T	AISI 316L	1
02	Blind lower opening	AISI 316L	1
04	Handle	AISI 304	1
05	Shaft seal	EPDM	1
08	Valve shaft	AISI 316L	1
11	Guide bushing	PTFE	1
12	Body cap	AISI 316L	1
20	O-ring	EPDM	1
20A	O-ring	EPDM	1
20B	O-ring	EPDM	3
21	Support	AISI 304	1
26	Hexagonal nut	AISI 304	1
26A	Lock nut	AISI 304	1
26B	Blind nut	AISI 304	1
34	Clamp	AISI 304	3
42	Separator	AISI 316L	1

Fig. NA/NB/NC/ND

8.3.18 Parts list FIG. MA/MB/MC/MD MANUAL OPERATION

POS	DESIGNATION	DN						
		25/1"	40/1½"	50/2"	65/2½"	80/3"	100/4"	
01	Lower body L	DIN	351275.6	351277.6	351278.6	351279.6	351280.6	351281.6
		Inches	351282.6	351283.6	351284.6	351285.6	351286.6	351287.6
01A	Upper body L	DIN	351275.6	351277.6	351278.6	351279.6	351280.6	351281.6
		Inches	351282.6	351283.6	351284.6	351285.6	351286.6	351287.6
01/01A	Up/Low body T	DIN	C-35041AT	C-35041CT	C-35041DT	C-35041ET	C-35041FT	C-35041GT
		Inches	C-35043AT	C-35043CT	C-35043DT	C-35043ET	C-35043FT	C-35043GT
02	Blind lower opening	451657.6	451658.6	451659.6	451660.6	451661.6	451662.6	
04	Handle	C-45055A			C-45055B			
05	Shaft seal	450811.E						
08	Valve shaft	To be consulted						
11	Guide bushing	450888.I			450889.I			
12	Body cap	450890.6	450891.6	450892.6	450893.6	450894.6	450895.6	
20	O-ring	O4029553	O4037453	O4040653	O4059653	O4078753	O4097753	
20B	O-ring	O4040835	O4053535	O4066235	O4091635	O4098035	O4120235	
21	Support	350373.4	350374.4	350375.4	350376.4	350377.4	350378.4	
26	Hexagonal nut	TU5012			TU5016			
26A	Lock nut	451271.4						
26B	Blind nut	TU4012			TU4016			
34	Clamp	1703200	1703212	1703300	173400	173412	1703600	
42	Separator	450896.6	450897.6	450898.6	450899.6	450900.6	450901.6	

8.3.19 Sealing kit list for PNEUMATIC OPERATION

DESIGNATION	DN					
	25	40	50	65	80	100
EPDM Sealing Kit Type NL/NT	KE-N025	KE-N040	KE-N050	KE-N065	KE-N080	KE-N100
VITON Sealing Kit Type NL/NT	KV-N025	KV-N040	KV-N050	KV-N065	KV-N080	KV-N100
EPDM Sealing Kit Type KE/KF/KG/KH	KE-K025	KE-K040	KE-K050	KE-K065	KE-K080	KE-K100
VITON Sealing Kit Type KE/KF/KG/KH	KV-K025	KV-K040	KV-K050	KV-K065	KV-K080	KV-K100
EPDM Sealing Kit Type NA/NB/NC/ND	KE-A025	KE-A040	KE-A050	KE-A065	KE-A080	KE-A100
VITON Sealing Kit Type NA/NB/NC/ND	KV-A025	KV-A040	KV-A050	KV-A065	KV-A080	KV-A100
EPDM Sealing Kit Type MA/MB/MC/MD	KE-M025	KE-M040	KE-M050	KE-M065	KE-M080	KE-M100
VITON Sealing Kit Type MA/MB/MC/MD	KV-M025	KV-M040	KV-M050	KV-M065	KV-M080	KV-M100

8.3.20 Sealing kit list for MANUAL OPERATION

DESIGNATION	DN					
	25	40	50	65	80	100
EPDM Sealing Kit Type NL/NT	KE-NM025	KE-NM040	KE-NM050	KE-NM065	KE-NM080	KE-NM100
VITON Sealing Kit Type NL/NT	KV-NM025	KV-NM040	KV-NM050	KV-NM065	KV-NM080	KV-NM100
EPDM Sealing Kit Type KE/KF/KG/KH	KE-KM025	KE-KM040	KE-KM050	KE-KM065	KE-KM080	KE-KM100
VITON Sealing Kit Type KE/KF/KG/KH	KV-KM025	KV-KM040	KV-KM050	KV-KM065	KV-KM080	KV-KM100
EPDM Sealing Kit Type NA/NB/NC/ND	KE-AM025	KE-AM040	KE-AM050	KE-AM065	KE-AM080	KE-AM100
VITON Sealing Kit Type NA/NB/NC/ND	KV-AM025	KV-AM040	KV-AM050	KV-AM065	KV-AM080	KV-AM100
EPDM Sealing Kit Type MA/MB/MC/MD	KE-MM025	KE-MM040	KE-MM050	KE-MM065	KE-MM080	KE-MM100
VITON Sealing Kit Type MA/MB/MC/MD	KV-MM025	KV-MM040	KV-MM050	KV-MM065	KV-MM080	KV-MM100

Клапаны — Распределительный односедельный клапан К

<http://k-tep.com.ua/>

✉ k-tep@ukr.net

■ Office +38 044 2091823

■ МТС +38 066 9076563

■ Киевстар +38 098 3676414

Skype: [k-teppumps](#)

Замечания

Условия поставки: DDP склад г. Киев

Заметки

Время поставки рассчитано согласно дате предложения и изменяется в зависимости от даты подтверждения заказа.

Разещая заказ, покупатель принимает предложение и все спецификации, характеристики и условия, указанные в данном документе.