

**ИНСТРУКЦИЯ ПО УСТАНОВКЕ И ТЕХНИЧЕСКОМУ
ОБСЛУЖИВАНИЮ**

ДОННЫЙ МИКСЕР ME-6100

**INSTALLATION, SERVICE AND MAINTENANCE
INSTRUCTIONS**

TANK BOTTOM MIXER SERIE 6100



INOXPA, S.A.
c/Telers, 54 Aptdo. 174
E-17820 Banyoles
Girona (Spain)

Original Manual

03.600.30.00EN
ED. 2011/12

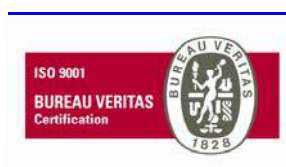



EC DECLARATION OF CONFORMITY
(In accordance with Directive 2006/42/EC, annex II, part A)

We, the manufacturer:

c/ Telers, 54
17820 Banyoles (Girona) - Spain

Hereby declare that the products

MIXER

ME-6100

Name

Type

are in conformity with the provisions of the Council Directives:

Machine Directive 2006/42/EC, and comply with the essential requirements of said Directive and the harmonised standards:

UNE-EN ISO 12100-1/2:2004
UNE-EN ISO 13857:2008
UNE-EN 953:1997
UNE-EN ISO 13732-1:2007

Low-Voltage Directive 2006/95/CE (replacing Directive 73/23/CE), and conform to UNE-EN 60204-1:2006 and UNE-EN 60034-1:2004

Electromagnetic Compatibility Directive 2004/108/CE (replacing Directive 89/336/CE), and conform to UNE-EN 60034-1:2004

In conformity with **Regulation (CE) No. 1935/2004** on materials and objects intended to come into contact with foodstuffs (repealing 89/109/EEC), in accordance with which the materials in contact with the product do not transfer its constituents to the foodstuffs in quantities large enough to put human health at risk.

Banyoles, 2012

Josep Mª Benet
Technical manager

1. Safety instructions

1.1. SAFETY INSTRUCTIONS

This instruction manual contains the basic indications that should be complied with during installation, start-up and maintenance. Consequently, it is essential that, before installation, both the installer and the plant technical manager read this instruction manual and that it be permanently available alongside the mixer or corresponding installation. Not only must the detailed safety instructions in this chapter be complied with, but so also should the special measures and recommendations added in the other chapters of this manual.

1.2. SYMBOLS USED

The safety instructions included in this manual, whose non-compliance may cause risk to persons or to the machine and its correct operation, are expressed by means of the symbols indicated below:



Danger for people in general.



Danger! Suspended loads.



Electric danger.



Danger of injury caused by the agitator.



Danger for mixer and its operation.



Commitment to guarantee safety at the workplace.

1.3. GENERAL SAFETY INSTRUCTIONS



- Read the instructions in this manual before installing the mixer and before starting it up.
- The installation and use of the mixer must always be in accordance with the rules applying to health and safety.
- Connect the mixer to the tank before starting it up.
- Before starting up the mixer, check that it be correctly anchored and that the shaft be perfectly aligned. Poor alignment and/or excessive force in fitting may cause serious mechanical problems for the mixer.
- Check the other components of the installation (e.g. tank, valves, and pipes).



- Specialized personnel should carry out all electrical work.
- To control the engine characteristics and its control panel, especially in areas where there is a risk of fire or explosion, the user company's technical manager shall establish danger areas (area 0 – 1 – 2).
- Do not spray the motor directly during cleaning.
- Do not disassemble the agitator without previously disconnecting the power supply. Remove the fuses and disconnect the motor feed cable.



- Do not operate the mixer if turning components do not have the protection system or if they are badly fitted.
- The mixer has rotating parts. Do not put hands or fingers into an mixer whilst it is operating. This may cause serious injury.
- Do not touch any of the parts of the mixer that are in contact with liquid whilst in operation. If the mixer works with hot products at temperatures exceeding 50 °C, there is a risk of burns. In these cases, collective protective measures should be put in order of priority (distance, protective screen, heat resistance), or – failing this possibility- to provide individual protection (gloves).



- Take all precautions when moving or assembling the mixer. A trans pallet will be used for this purpose. Aim to support the mixer between the motor and the lantern to make the assembly more stable.



- Withdraw all the tools used in mounting before starting up the mixer.
- The mixer is unable to work without liquid. Standard mixer are not designed to operate during the filling or emptying of tanks.



- Do not exceed the mixer's maximum operating conditions. Do not modify the operating parameters that were initially set for the mixer without the prior written consent of INOXPA.
- The mixers and their installation may cause noise levels that exceed 85 dB (A) in some unfavorable operating environments. In such cases, operators should wear hearing protection.

1.4. GUARANTEE

We wish to point out that any warranty issued will be null and void and that we are entitled to an indemnity for any civil liability claim for products which might be filed by third parties if:

- operation and maintenance work has not been done following the corresponding instructions; the repairs have not been made by our personnel or have been made without our written authorization;
- modifications are made to our material without prior written authorization;
- the parts or lubricants used are not original INOXPA parts/lubricants;
- the material has been improperly used due to error or negligence or have not been used according to the indications and the intended purpose.
- all components subject to wear are excluded from the guarantee.

The General Delivery Terms which you have already received are also applicable.

1.5. INSTRUCTIONS MANUAL

The information provided in the instruction manual refers to updated data.

We reserve the right to modify the design and/or manufacturing specifications of our products as required, devoid of any obligation on our part to adapt any product supplied prior to such alteration.

The technical information made available in this instruction manual, together with the graphs and technical specifications provided, shall continue to belong to us and should not be used (except for starting up this installation), copied, photocopied, made available or otherwise given to third parties without our prior written consent.

INOXPA is reservation the right to modifying this instructions manual without previous notice.

1.6. INOXPA SERVICE

In the event of doubt or should you require a fuller explanation on particular data (adjustment, assembly, disassembly...), please do not hesitate to contact us.

2. Index

1. Safety instructions	
1.1. Safety instructions.....	2
1.2. Symbols used.	2
1.3. General safety instructions.....	2
1.4. Guarantee	3
1.5. Instructions manual	3
1.6. Inoxpa service	3
2. Index	
3. Reception, storage and transport	
3.1. Reception	6
3.2. Storage	6
3.3. Transport	6
4. Identification, description and use	
4.1. Identification	7
4.2. Description	7
4.3. Operating principle.....	7
4.4. Application	7
5. Installation and assembly	
5.1. Installation and assembly	8
5.2. Location	8
5.3. Assembly.....	8
5.4. Electrical connection.....	8
6. Start-up, operation and shutdown	
6.1. Start-up.....	9
6.2. Operation	9
7. Maintenance and conservation	
7.1. Maintenance	10
7.2. Lubrication	10
7.3. Spare parts.....	10
7.4. Conservation.....	10
8. Operating problems: causes and solutions	
9. Disassembly and assembly	
9.1. Electrical safety.....	12
9.2. Disassembly and assembly to the mixer.....	12
9.3. Disassembly and assembly mechanical seal	12
9.4. Disassembly and assembly mechanical seal with flushing	13
9.5. Disassembly and assembly of the shaft, lantern and drive.	13
10. Technical specifications	
10.1. Technical specifications	15
10.2. Dimensions	16
10.3. Cross-section ME-6103/6110 Mechanical seal.....	17
10.4. Parts list ME-6103/6110 mechanical seal.....	18
10.5. Cross-section ME-6103/6110 mechanical seal with flushing.....	19
10.6. Part list ME-6103/6110 mechanical seal with flushing	19

10.7. Assembly dimensions ME-6103/6110 Mechanical seal	20
10.8. Cross-section ME-6125/6130 mechanical seal.....	21
10.9. Parts list ME-6125/6130 Mechanical seal.....	22
10.10. Cross-section ME-6125/6130 mechanical seal with flushing	23
10.11. Part list ME-6125/6130 mechanical seal with flushing	23
10.12. Assembly dimensions ME-6125/6130 Mechanical seal	24

3. Reception, storage and transport

3.1. RECEPTION



INOXPA is not liable for any deterioration of the material caused by its transport or unpacking. Visually check that the packaging has not been damaged.

The following documentation is included with the mixer:

- Shipping documents.
- Instructions and Servicing manual for the mixer.
- Instructions and Servicing manual for the motor.

Unpack the mixer and check the following:

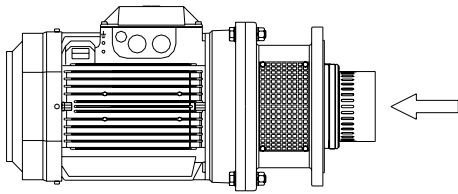

- The mixer stator and rotor, removing any remaining packaging material.
- Check that the mixer and motor have not suffered any damage.
- If not in good material condition and/or if not all the parts are included, the shipping carrier should submit a report as soon as possible.

3.2. STORAGE

If the mixer is not immediately installed, it must be stored in an appropriate place. The mixer must be stored in a horizontal position and on some wooden or similar supports.

3.3. TRANSPORT

If the mixer is not immediately installed, it must be stored in an appropriate place. The mixer must be stored in a horizontal position and on some wooden or similar supports.



Depending on the model, the mixer are too heavy to store or install manually. Use an adequate means of transport.

Type	Weight [kg] with IE2 motor
ME-6103	35
ME-6105	65
ME-6110	86
ME-6125	180
ME-6125 (T.180)	205
ME-6130	255

4. Identification, description and use

4.1. IDENTIFICATION

The mixer is identified by means of a plate stating its characteristics attached to the motor. The type of mixer and serial number are on the plate. See figure 4.1 and 4.2.

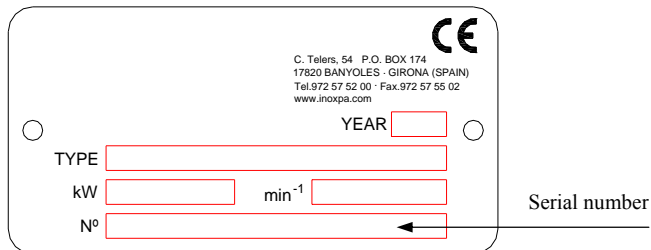

Figure 4.1: Characteristics plate mixer

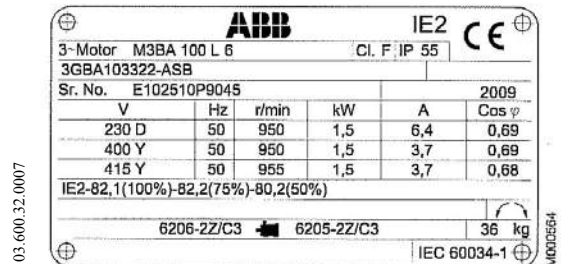

Figure 4.2: Characteristics plate motor

Example:

Head assembly

ME - 6125
1 2

1. Number of MIXER.

ME = MIXER emulsifier

2. Size.

6103
6105
6110
6125
6130

4.2. DESCRIPTION

The ME-6100 range includes high-shear tank-bottom mixers

The mixers in this range have been designed so that the mechanical seal is accessible from inside the tank. As such, whenever it is necessary to change the seal, there is no need to detach the mixer from the tank. This range can be used in both open and closed tanks at atmospheric pressure or operating under pressure or in vacuum. They are especially suitable for work in conjunction with anchor-type agitators.

4.3. OPERATING PRINCIPLE

- The impeller sucks the fluid through the holes at the top.
- Once this suction is completed, the fluid reaches the impeller blades and these push it towards the stator where it is sheared.
- The fluid is expelled radially through the stator slots at high speed.

4.4. APPLICATION

Bottom mixers are suitable for particle-reduction processes, dissolution, dispersion, and emulsion. Given their hygienic design, these mixers are suitable for industries as demanding as cosmetics, foodstuffs, and pharmaceuticals. They can also be used in other types of industries such as adhesives, chemicals, paints, and plastics.



Each mixer has performance limits. The mixer was selected for a given set of mixing conditions when the order was placed. INOXPA shall not be held responsible for any damage that might be suffered or malfunctioning of the equipment if the information provided by the buyer is incomplete or incorrect (e.g. nature of the fluids or installation details).

5. Installation and assembly

5.1. INSTALLATION AND ASSEMBLY



If the mixer is supplied without a drive or other element, the purchaser shall be responsible for its assembly, installation, start-up and operation.

5.2. LOCATION

Place the mixer in such a way as to facilitate inspection and servicing. Leave sufficient room around the mixer for adequate servicing, separate, even when it is in operation. It is very important to be able to obtain access to the electrical connection mechanism of the mixer, even when it is in working mode.

To achieve an effective mixing process it may be necessary to fit baffles to the bottom of the tank. Consult our technical department for each particular application. If required, the approximate dimensions of the baffles in relation to the diameter of the tank are shown in figure 5.1 and table 5.1.

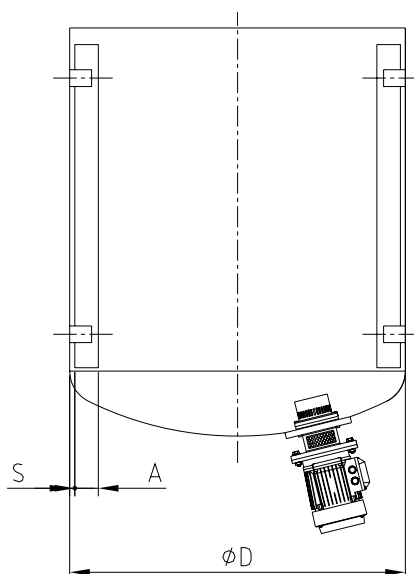

Figure 5.1

∅ D	300	400	500	600	800	1000	1200	1600	2000	2500	3000	3500	4000
A	20	30	35	40	50	70	80	115	130	180	200	240	280
S	5	5	10	10	10	15	20	20	30	30	50	50	50

Table 5.1

5.3. ASSEMBLY

- Place and assemble the mixer at the bottom of the tank ensuring that the O-ring is fitted.
- Once placed on the tank flange, place the screws and washers in their corresponding bore holes and fasten them tightly.
- Make sure that the order components of the installation are prepared and ready for start-up of the mixer.



Force should never be applied to the end of the agitator shaft, as it can easily suffer permanent damage.

5.4. ELECTRICAL CONNECTION

Before connecting the electric motor to the mains, check the local regulations and the corresponding standards regarding electrical safety. Take special account of those parts referring to command and control of the mixer. Check the manufacturer's instruction manual of the motor for connecting it to the mains.



Let the electrical connection of the motors to qualified personnel. Take the necessary measures in order to prevent any type of breakdown.

The motor should be protected with devices against overload and short-circuits.

It is not possible to use the agitator in areas of risk of fire or explosion if this has not been included in the order. Risk areas (zones 0 -1 - 2).

6. Start-up, operation and shutdown

Mixer start-up shall be able to be carried out if the detailed instructions in the section on installation and assembly have previously been realized.

6.1. START-UP

- Check that the electrical supply is appropriate for what is indicated on the motor plate.
- Check the tank's liquid level. Unless specified in the order, the mixer cannot function during tank filling or emptying.
- Check that the mechanical seal is in the condition required to operate properly (see technical specifications).



The mixer can NEVER run without a product. The agitation element must be submerged at least to a height above twice its diameter.

- All the protectors must be in place.
- The performance of the mixer-emulsifier depends on the viscosity of the fluid being mixed. To properly operate the equipment, follow this loading procedure:
 - Pour all the low-viscosity components inside the vessel.
 - Start up the mixer.
 - Check that the direction of rotation of the impeller is correct (it must rotate clockwise looking from the drive side See figure 6.1.
 - Add the remaining fluid or soluble components.
 - Add any solids that require to be cut or a predetermined time for reaction.
 - Add the remaining components, including solids to stabilize the preparation or to increase viscosity.
- Check the motor's electrical consumption.



Respect the direction of rotation of the agitation element as indicated by the arrow stuck on the motor. The wrong direction will cause a loss of mixer efficiency.

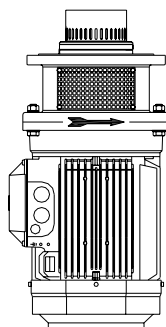

Figure 6.1

6.2. OPERATION



Do not modify the operating parameters for which the mixer was initially selected without prior written consent of INOXPA. (Risk of deterioration and danger for the user). Follow the operating instructions and safety indications described in the instructions manual of the tank on which the mixer is mounted.



Mechanical hazards (drag, shearing, cutting, strike, squashing, clipping, etc.). If the mixer element is accessible from above or at the man way of the tank then the user is exposed to the aforementioned hazards.

The tank should be equipped with protection devices and safety equipment. Check the manufacturer's instructions manual.



The introduction of a solid object or raw material may cause breakage of the agitation element or the breakage of other mechanical parts and endanger safety and they warranty.

7. Maintenance and conservation



Maintenance work can only be carried out by qualified personnel that are trained and equipped with the necessary resources to carrying out this work.
All parts or materials that are replaced must be properly disposed of / recycled in accordance with the current directives applicable in each area.



Before beginning maintenance work, ensure that the electric motor is disconnected and that the tank is empty.

7.1. MAINTENANCE

- Inspect the mixer regularly.
- Do not fail to keep the mixer clean.
- Check the state of the motor.
- Check the sealing: mechanical seal.

Motor maintenance shall be carried out in accordance with the manufacturer's instructions. See the instructions manual.

7.2. LUBRICATION

Should greasing of the motor bearings shall be carried out in accordance with the manufacturer's instructions.

7.3. SPARE PARTS

To order spare parts it is necessary to indicate the type and serial number included on the mixer's characteristics plate, as well as the position and description of the part as found in chapter 10, [technical specifications](#).

7.4. CONSERVATION

If the agitator is out of service for a considerable period of time, clean and treat the parts with VG 46 mineral oil. The shaft must be stored in the horizontal position and on wooden supports or on supports of a similar material.

8. Operating problems: causes and solutions

Operating problems	Probable causes
Motor overload.	1, 2, 3, 10.
Insufficient mixer.	1, 3, 4, 5.
Vibrations and noise.	6, 7, 8.
Leakage.	9, 10.

Probable causes		Solutions
1	Viscosity of the liquid too high.	Reduce the viscosity, e.g. by heating the liquid.
2	High density.	Increase motor power.
3	Tank too big for the chosen mixer.	Check with the technical department.
4	Wrong direction of rotation.	Change direction of rotation.
5	Mixer speed too low.	Increase the speed.
6	Liquid level insufficient or none.	Check liquid level in the tank.
7	Shaft bent.	Replace the shaft.
8	Worn bearing to motor.	Replace the motor bearing.
9	V-ring worn or damaged.	Replace the V-ring.
10	The impeller rubs	Decrease the temperature.



If the problems persist stop using the mixer immediately. Contact the MIXER manufacturer or the representative.

9. Disassembly and assembly



The assembly and disassembly of the agitators should only be carried out by qualified personnel. Ensure that staff read this instruction manual carefully, especially those parts that make direct reference to their work.

9.1. ELECTRICAL SAFETY

Ensure that the motor starter is turned off when carrying out disassembly or assembly work on the agitator.



- Place the agitator switch in the “off” position.
- Block the electrical panel and put a warning notice on it.
- Take out the fuses and take them with you to the work area.

9.2. DISASSEMBLY AND ASSEMBLY TO THE MIXER

9.2.1. Disassembly of the stator

- Empty the tank.
- Disconnect the cables from the motor terminals.
- Remove the protector (47) by taking out the screws (52) and washers (53).
- Disconnect the pressure vessel if there is.
- Enter the tank through the inspection hatch if possible. If not, detach the equipment from its location. In the latter case, remove the screws and washers fastening the mixer to the tank. This process must be carried out using a pallet truck in order to support the mixer and move it. Take care to ensure that the mixer is supported by the lantern/motor connection part for better stability and to prevent it from falling.
- Remove the stator (22), from inside the tank where applicable, by removing the Allen screws (51A).
- Remove O-ring (80A) from the stator (22).

9.2.2. Assembly the stator

- Place the O-ring (80A) to the stator (22).
- The stator (22) must be assembled from the inside of the tank. Attached the mixer to the tank fastening it with screws and washers. The process must be assisted by a pallet truck: to hold the mixer and to transport it. The mixer must be supported by the lantern/motor connection part for better stability to prevent it from falling.
- Attach the stator (22) to the cover (03) with the screws (51A).
- Connect the pressure vessel if there is.
- Place the protectors (47) to the lantern (04) and fasten them with screws (52) and washers (53).

9.3. DISASSEMBLY AND ASSEMBLY MECHANICAL SEAL

9.3.1. Disassembly

- All the steps from part 9.2.1 must be carried out.
- Remove the impeller (21) hold with a spanner through the flat surfaces machined on the shaft (05) and by means of a tubular tool remove the nut (45) by a anticlockwise hit with a hammer.
- Remove the key (61) from the shaft (05).
- Remove the rotary part of the mechanical seal (08) from the impeller (21).
- Remove the cover (03) by taking the screws out (51).
- Loosen and remove the fittings of the refrigeration (92), in the case of having refrigeration.
- Once the cover is out (03), remove the stationary part of the mechanical seal (08) remove the spring by turning it through the cover pins .
- Remove the o-ring (80B) from the cover (03).

9.3.2. Assembly

- Assemble the o-ring (80B) on the cover (03).
- Before placing the stationary part of the mechanical seal (08) on the cover (03) check the assembly clearances (see chapter 10.7 or 10.11).
- Place the spring of the mechanical seal on the cover (03) by turning it through the pins, after that the stationary part of the mechanical seal (08), matching the cover pins (03).
- In the case of having refrigeration, place the refrigeration connections fittings (92) on the cover (03).
- Assemble the cover (03) with the mechanical seal (08) to the lantern (04) (ME-6103/6110) or the base plate (42) (ME-6125/6130) by means of Allen screws (51).
- Place the rotary part of the mechanical seal (08) to the impeller (21).
- Assemble the key (61) to the shaft (05).
- Place the impeller (21) together with the mechanical seal (08) to the shaft of the mixer (05).
- Assemble the impeller (21) to the shaft (05) by means of the nut (45) having placed previously the o-ring (80B) to the nut

- Hold by means of a spanner through the flat surfaces machined on the shaft (05) and by means of a tubular tool remove the nut (45), tighten strongly up until the impeller.
- Check the clearance between the impeller (21) and the cover (03). *This must be approximately of 0.5 mm all around.*
- Make all the steps described on chapter 9.2.2.

9.4. DISASSEMBLY AND ASSEMBLY MECHANICAL SEAL WITH FLUSHING

9.4.1. Disassembly

- Make all the steps from chapter 9.3.1.
- Remove by means of a pliers the elastic ring (66) and the lip seal (88) from the cover (03) by means of a rubber hammer.
- Check the state of the Speedi-Sleeve (17). In the case that the surface is scratched or in bad conditions, it is required to be replaced by a new one.

9.4.2. Assembly

- In the case of replacing the Speedi-Sleeve (17), the replacement will be carried out according to the instructions of the manufacturer.
- By means of a rubber hammer, place the lip seal(88) (*with the lip according to the drawing*) on the cover (03) and finally by means of a pliers assemble the elastic ring (66).
- Proceed according to the steps described on chapter 9.3.2

9.5. DISASSEMBLY AND ASSEMBLY OF THE SHAFT, LANTERN AND DRIVE

- Proceed according to the steps described on chapter 9.3. or 9.4 (*depending on the sealing type*).

9.5.1. Disassembly size 6103 to 6105

- Remove the splash ring (82) and the V-ring (81) from the shaft (05).
- Remove the drive (93) from underneath the lantern (04) removing the screws (52B) and washers (53B) and the nut (54).
- Remove the shaft (05) from the drive (93) by loosening the grab screws (55).

9.5.2. Disassembly size 6110

- Remove the splash ring (82) and the V-ring (81) from the shaft (05).
- Remove the drive (93) from underneath the lantern (04) removing the screws (52B) and washers (53B).
- Remove the counter flange (23) from the lantern (04) removing the screws (52A) and washers (53A).
- Remove the shaft (05) from the drive (93) by means of loosening the grab screws (55).

9.5.3. Disassembly size 6125 to 6130

- Remove the splash ring (82) and the V-ring (81) from the shaft (05).
- Remove the drive (93) from underneath the lantern (04) removing the screws (52B) and washers (53B) and the nuts (54).
- Remove the shaft (05) from the drive (93) by means of loosening the grab screws (55).
- Remove the gasket (18) from the protector (47A) of the lantern (04).
- Finally remove the base plate (42) and the screws 50) from the lantern (04).

9.5.4. Assembly size 6103 to 6105

- Place the shaft (05) to the drive (93) without pressing it.
- Assemble the drive (93) in vertical position and fix the lantern (04) by means of washers (53B), the screws (52B) and nuts (54).
- Check the assembly clearance of the mechanical seal .See chapter 10.3. Once the checking is done, tighten the grab screws (55) of the shaft (05). *In the case of model 6103 the lantern (04) will need to be removed in order to tighten the grab screw (55) because it is hidden behind.*
- Place the V-ring (81) until the lips fit the lantern (04).
- Place the splash ring (82) on the shaft (05) approximately at the assembly position.
- Follow all the steps described in chapter 9.3 or 9.4 *depending on the sealing type.*

9.5.5. Assembly size 6110

- Place the shaft (05) to the drive (93) without pressing it.
- Assemble the flange (23) to the lantern (04) by means of screws (52A) and washers (53A).
- Place the drive (93) in vertical position and fix it to the counter flange (23) by means of washers (53B) and screws (52B).
- Check the assembly clearance of the mechanical seal .See chapter 10.3. Once the checking is done, tighten the grab screws (55) of the shaft (05). *In the case of model 6103 the lantern (04) will need to be removed in order to tighten the grab screw (55) because it is hidden behind.*
- Place the V-ring (81) until the lips fit the lantern (04).
- Place the splash ring (82) on the shaft (05) approximately at the assembly position.
- Follow all the steps described in chapter 9.3 or 9.4 *depending on the sealing type.*

9.5.6. Assembly size 6125 to 6130

- Place the gasket (18) and the protector (47A) to the lantern (04).
- Assemble the drive (93) to the lantern (04) by means of screws (52B), washers (53B) and nuts (54).
- Assemble the base plate (42) to the lantern (04) by means of screws (50).

-
- Place the shaft (05) to the end of the shaft drive. Check the assembly of the mechanical seal (*See chapter 10.3*) and tighten the grab screws (55).
 - Place the V-ring (81) to the shaft (05) until the lips fit on the protector (47A).
 - Place the splash ring (82) on the shaft (05), approximately at the assembly position.
 - Follow all the steps described in chapter 9.3 or 9.4 *depending on the sealing type*.

10. Technical specifications

10.1. TECHNICAL SPECIFICATIONS

The following limits should be considered for options:

Materials

Parts in contact with the product.....	AISI 316L
Other parts in stainless steel	AISI 304L
Seals in contact with the product	EPDM (standard)
Other materials for optional gaskets	Check with the supplier.
Surface finish.....	Polishing Ra 0.8.

Mechanical seal

Type of seal	Mechanical simple seal
Material stationary part.....	Graphite
Material Rotary part.....	Silicon carbide
Material V-ring.....	EPDM

Mechanical seal with flushing

Maximum pressure	0,5 bar (58 PSI).
Consumption.....	between 2,5-5 l/min.

Motor

Motor standard, construction IE2 B5 (Flange)

2 poles = 2900 min⁻¹ a 50Hz

4 poles = 1450 min⁻¹ a 50Hz

Protection.....	IP55
Connection.....	3 ~, 50Hz, 220-240VΔ/380-420VY 3 ~, 50Hz, 380-420VΔ/660-690VY

MIXER	Power kW	Speed min ⁻¹
ME-6103	2,2	3000
ME-6105	4	
ME-6125	7,5	
	18,5	
ME-6130	22	1500



When noise levels exceed 85 dB (A) in the area of work. The workers must wear hearing protection.

10.2. DIMENSIONS

Model	Size	Power kW	Speed Rpm	A	B	C	D	Q	R	Dimensions flange								
										ØDe	ØDc	ØDf	ØDn	Mxn	E	F	G	H
ME-6103	T-90L	2,2	3000	82	348	430	18	177	127	200	160	133.5	131.5	M16x4	25	12	21	15
ME-6105	T-112M	4		87	443	530	15	197	137	250	210	152	150	M16x8				
ME-6110	T-132S	7,5			478	565		261	164									
ME-6125	T-160L	18,5	1500	108	732	840	26	323	210	350	300	177	175	M16x8	30	15	27	20
		T-180M			22	777		885	354									
ME-6130	T-180L	22		144	776	920												

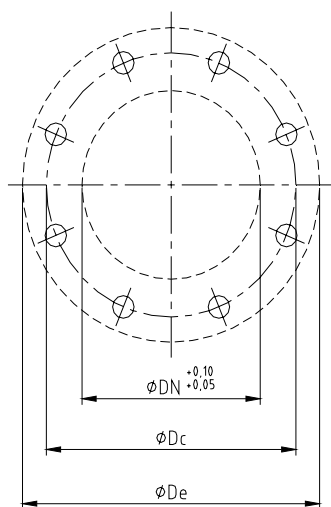
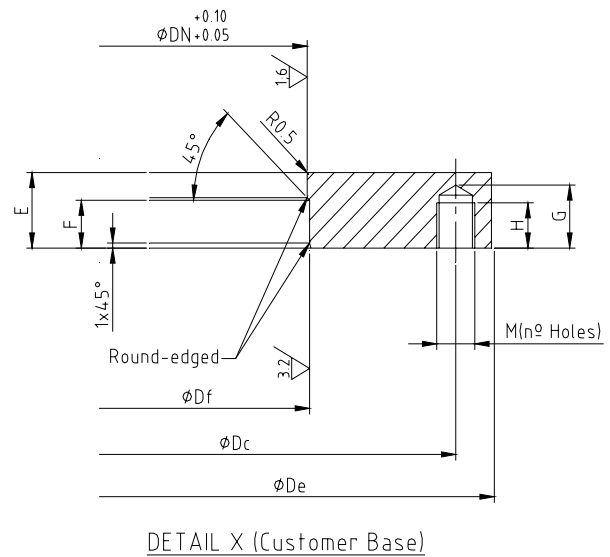
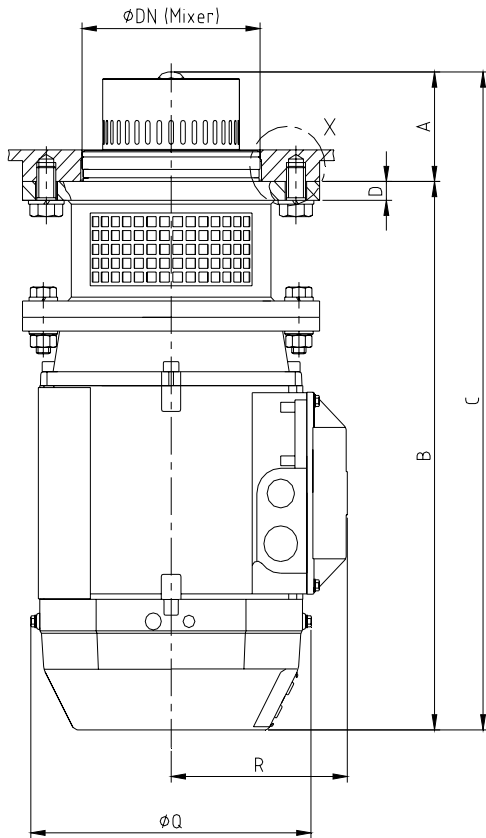

BASE MIXER

03.600.32.0009

10.3. CROSS-SECTION ME-6103/6110 MECHANICAL SEAL

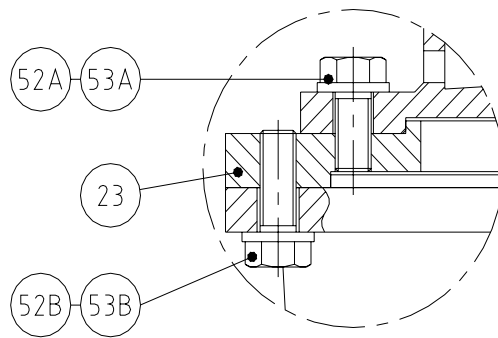
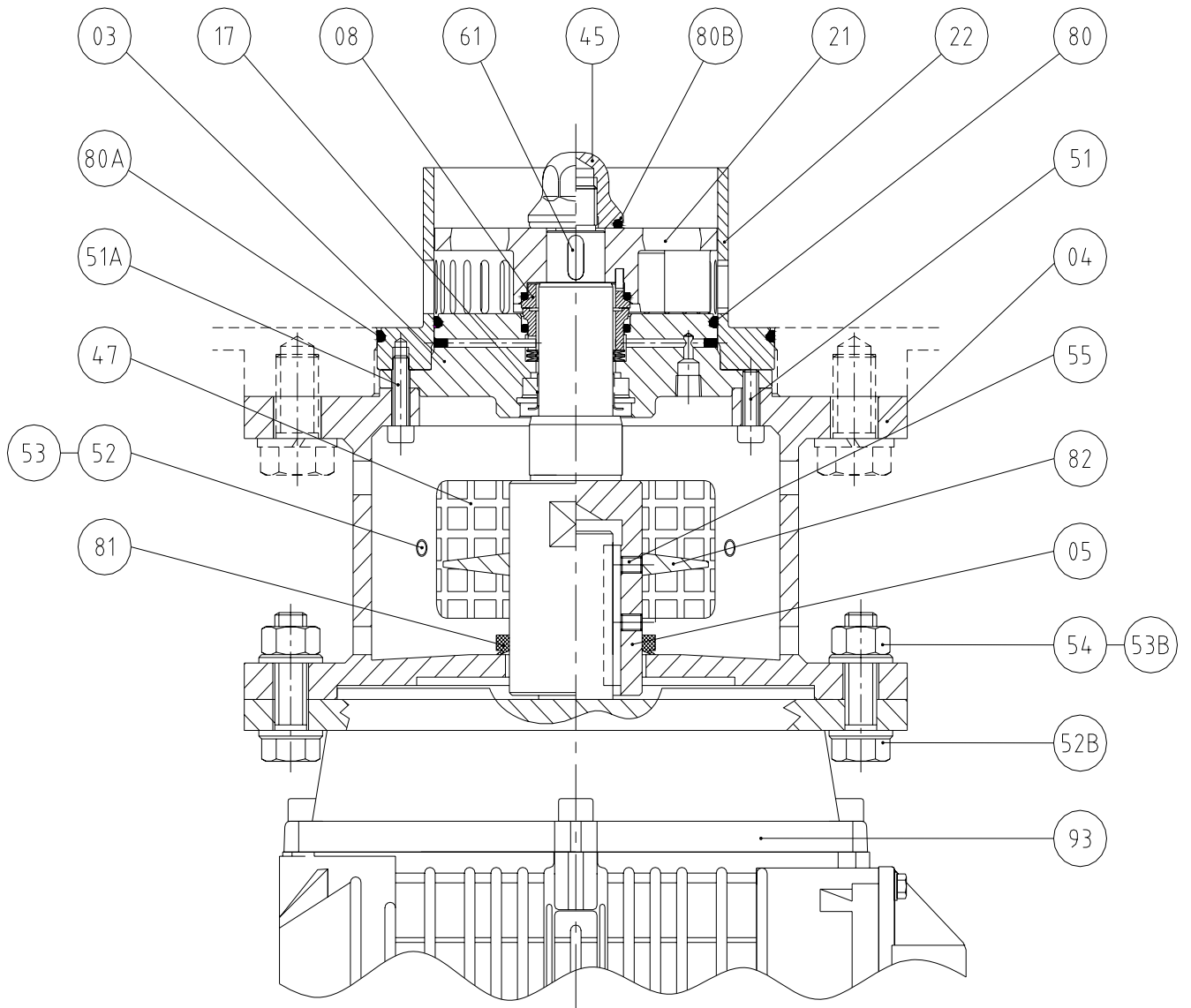

03.600.32.0008

DETAIL BASE PLATE ME-6110

10.4. PARTS LIST ME-6103/6110 MECHANICAL SEAL

Position	Quantity	Description	Material
03	01	Cover seal	AISI 316L
04	01	Lantern	AISI 304L
05	01	Shaft	AISI 316L
08	01	Mechanical seal	SiC/C/EPDM
17	01	Speedi Sleeve	-
21	01	Rotor	AISI 316L
22	01	Stator	AISI 316L
23	01	Base plate <i>(only for size ME-6110)</i>	F 1110
45	01	Blind nut	AISI 316L
47	02	Lantern protection	AISI 304L
51	04	Screw DIN-912	A2
51A	02	Screw DIN-912	A2
52	04	Screw DIN-933	A2
52A	04	Screw DIN-933	A2
52B	04	Screw	A2
53	04	Flat washer DIN-125	A2
53A	04	Flat washer DIN-125 <i>(only for size ME-6110)</i>	A2
53B	04	Flat washer DIN-125	A2
54	04	Nut DIN-934	A2
55	02	Stud DIN-916	A2
61	01	Key	AISI 316L
80	01	O-ring	EPDM
80A	01	O-ring	EPDM
80B	01	O-ring	EPDM
81	01	V-ring	NBR
82	01	Splash ring	EPDM
93	01	Drive	-

10.5. CROSS-SECTION ME-6103/6110 MECHANICAL SEAL WITH FLUSHING

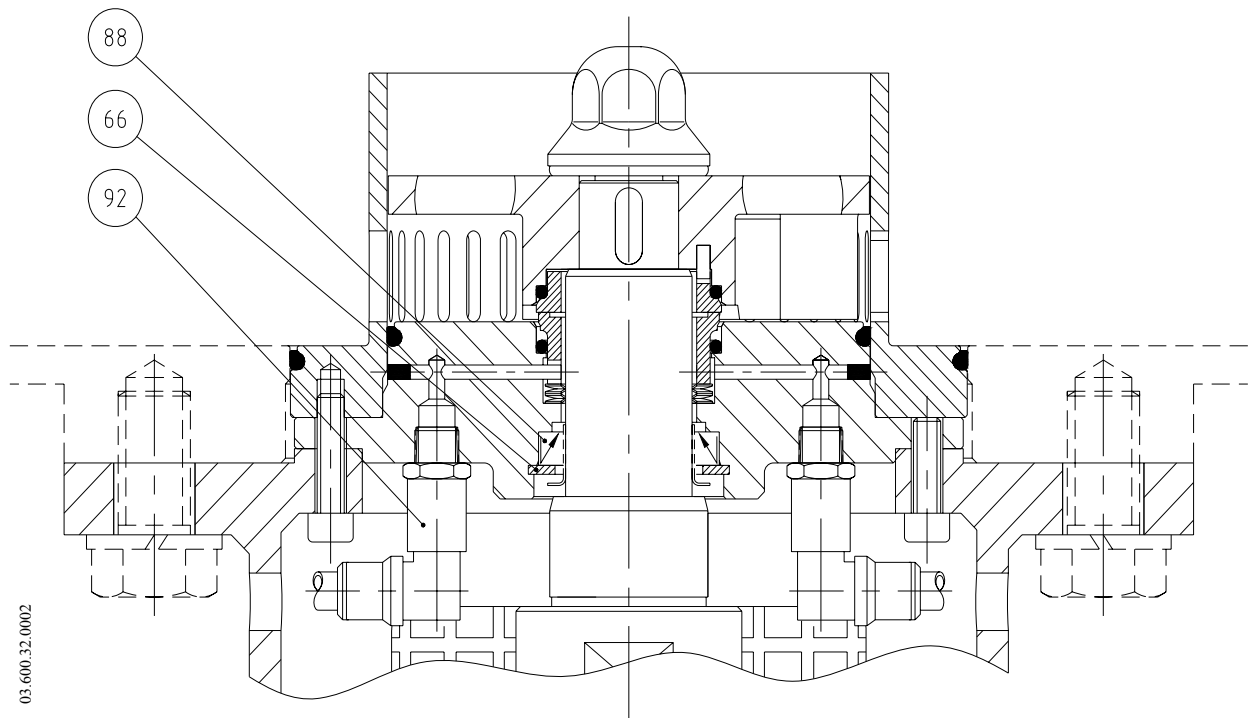

10.6. PART LIST ME-6103/6110 MECHANICAL SEAL WITH FLUSHING

Position	Quantity	Description	Material
66	01	Elastic ring DIN-472	AISI 316L
88	01	Lip seal B2PT	PTFE/St.St.
92	01	Fittings	St.St.

10.7. ASSEMBLY DIMENSIONS ME-6103/6110 MECHANICAL SEAL

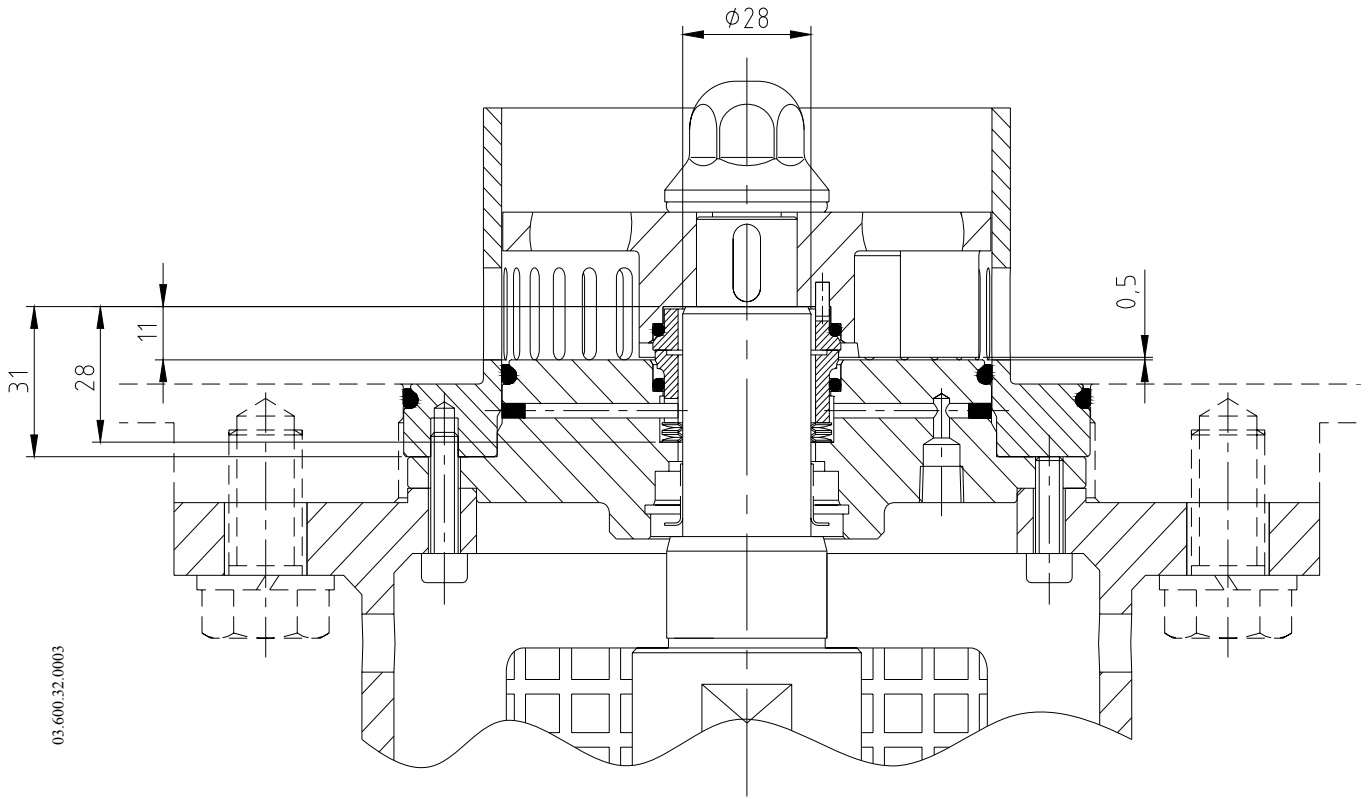

03.600.32.0003

10.8. CROSS-SECTION ME-6125/6130 MECHANICAL SEAL

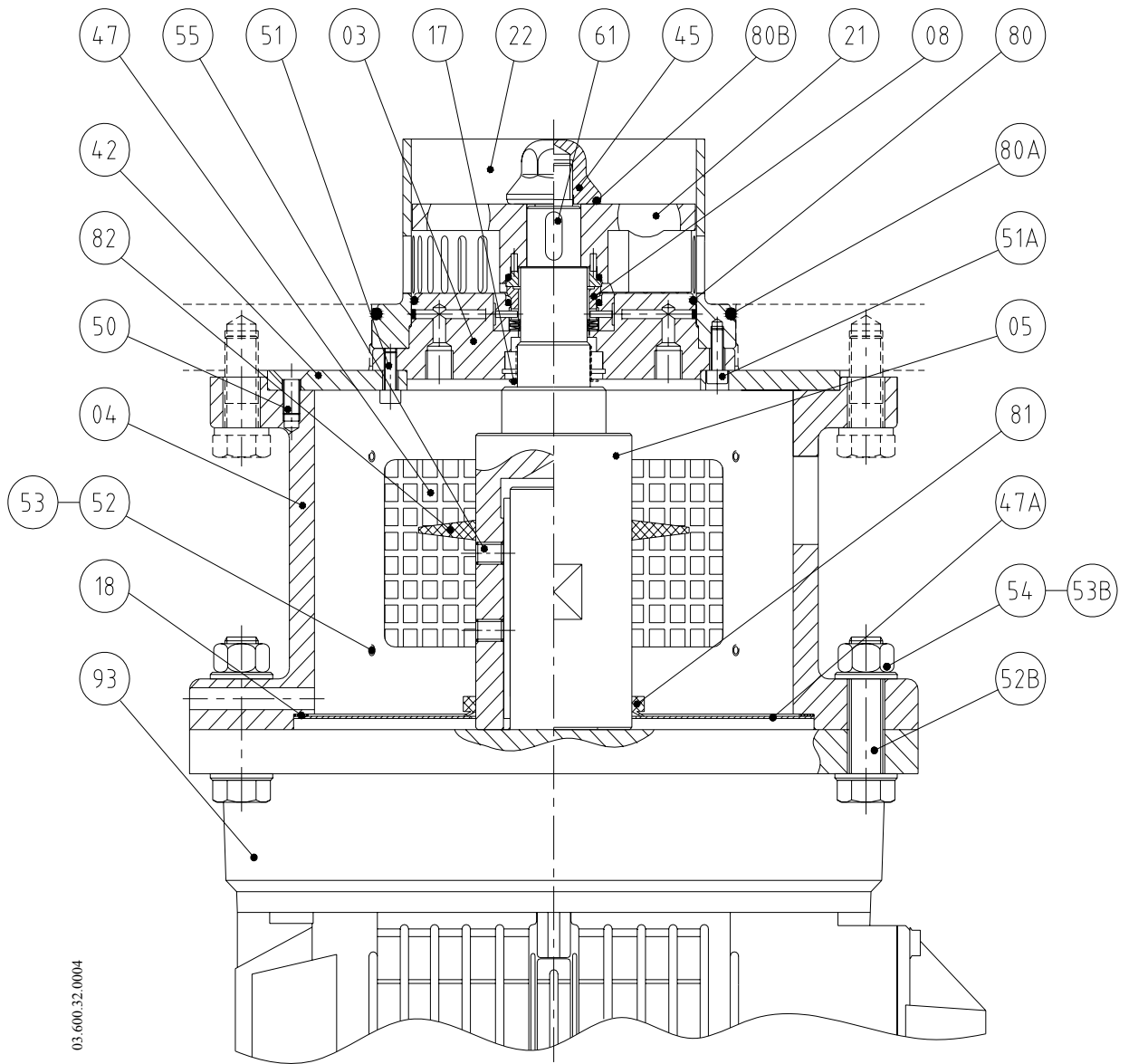

10.9. PARTS LIST ME-6125/6130 MECHANICAL SEAL

Position	Quantity	Description	Material
03	01	Cover seal	AISI 316L
04	01	Lantern	AISI 304L
05	01	Shaft	AISI 316L
08	01	Mechanical seal	SiC/C/EPDM
17	01	Speedi Sleeve	-
18	01	Special gasket	PTFE
21	01	Rotor	AISI 316L
22	01	Stator	AISI 316L
42	01	Base plate	AISI 316L
45	01	Blind nut	AISI 316L
47	02	Lantern protection	AISI 304L
47A	01	Protector	AISI 304L
50	02	Screw DIN-7991	A2
51	04	Screw DIN-912	A2
51A	02	Screw DIN-912	A2
52	08	Screw DIN-933	A2
52B	04	Screw DIN-933	A2
53	08	Flat washer DIN-125	A2
53B	08	Flat washer DIN-125	A2
54	04	Nut DIN-934	A2
55	02	Stud DIN-916	A2
61	01	Key	AISI 316L
80	01	O-ring	EPDM
80A	01	O-ring	EPDM
80B	01	O-ring	EPDM
81	01	V-ring	NBR
82	01	Splash ring	EPDM
93	01	Drive	-

10.10. CROSS-SECTION ME-6125/6130 MECHANICAL SEAL WITH FLUSHING

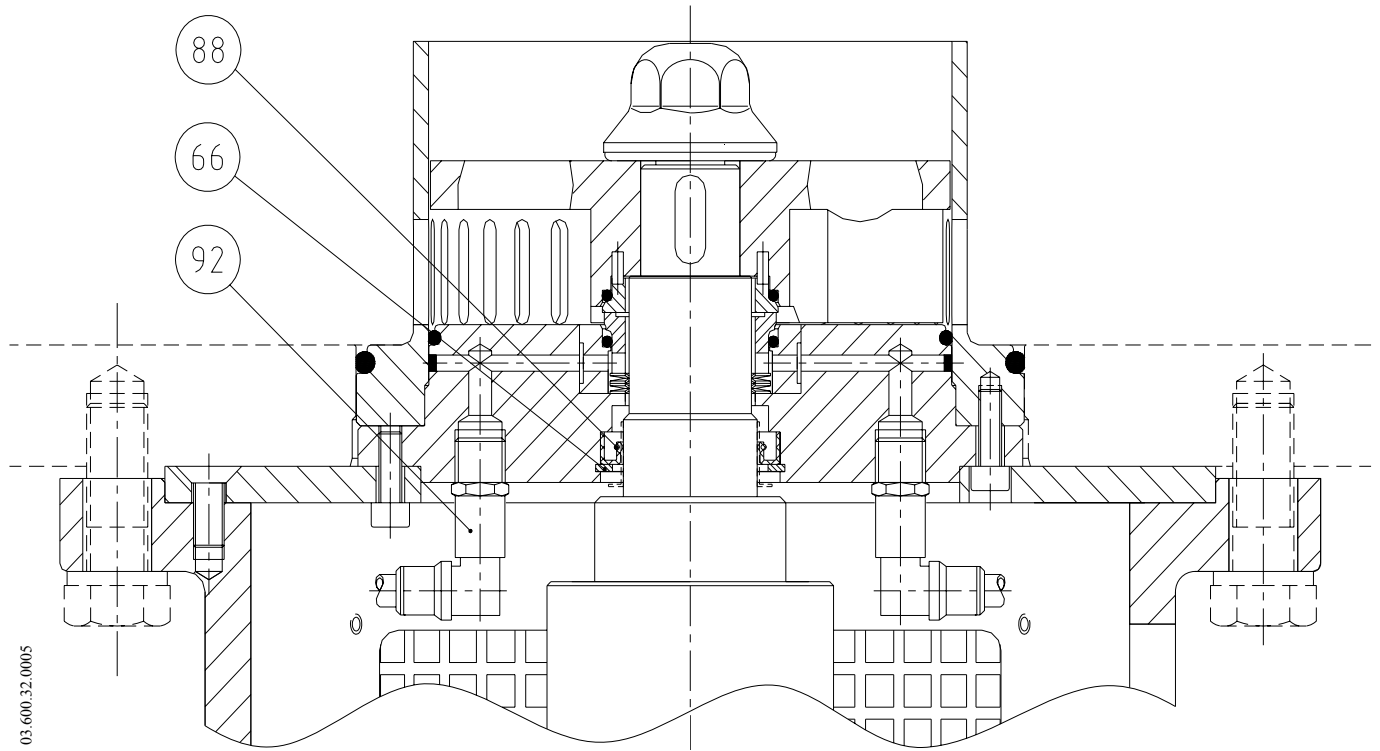

10.11. PART LIST ME-6125/6130 MECHANICAL SEAL WITH FLUSHING

Position	Quantity	Description	Material
66	01	Elastic ring DIN-472	A2
88	01	Lip seal B2PT	PTFE/St.St
92	02	Fittings	St.St.

10.12. ASSEMBLY DIMENSIONS ME-6125/6130 MECHANICAL SEAL

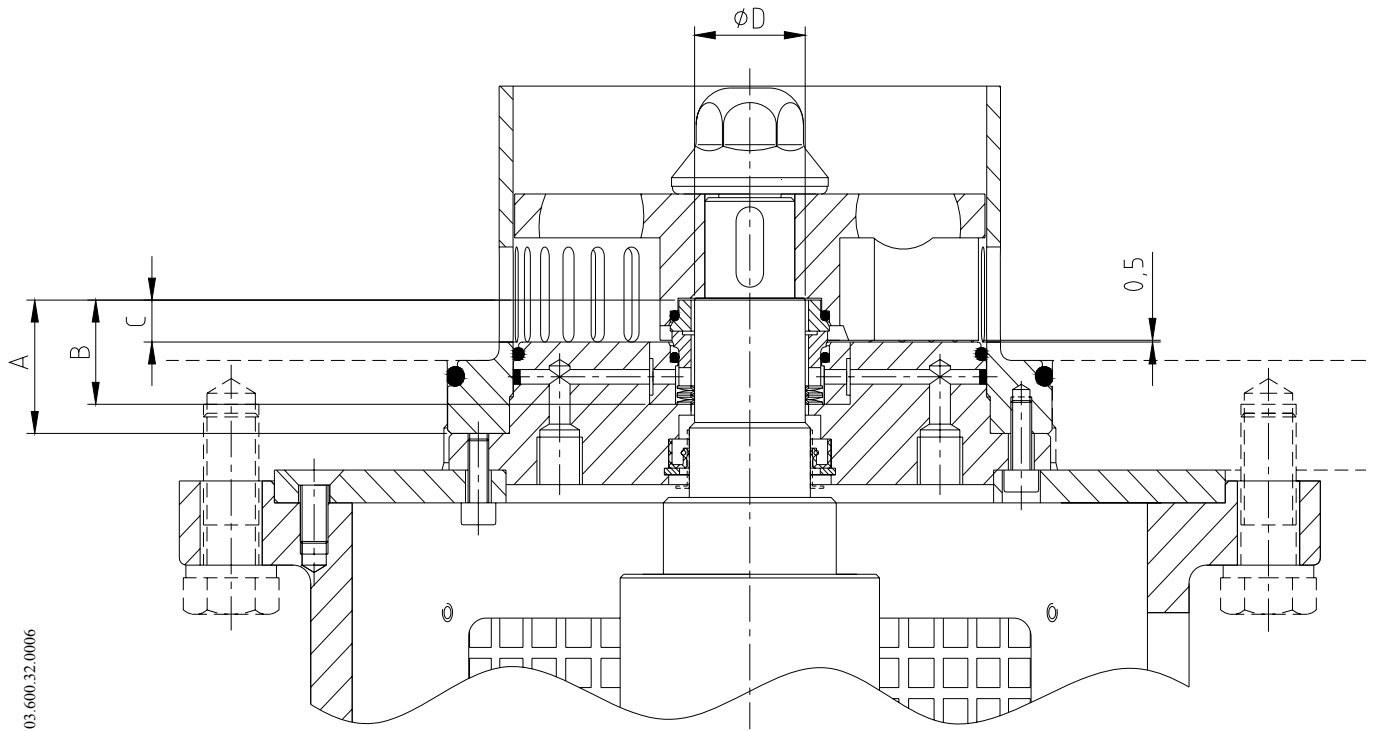

03.600.32.0006

Size	ϕD	A	B	C
ME-6125	$\phi 32$	37	29	12
ME-6130	$\phi 50$	42	34	13

Клапаны пищевые — Донный миксер

<http://k-tep.com.ua/>

✉ k-tep@ukr.net

■ Office +38 044 2091823

■ МТС +38 066 9076563

■ Киевстар +38 098 3676414

Skype: [k-teppumps](#)

Замечания

Условия поставки: DDP склад г. Киев

Заметки

Время поставки рассчитано согласно дате предложения и изменяется в зависимости от даты подтверждения заказа.

Размещая заказ, покупатель принимает предложение и все спецификации, характеристики и условия, указанные в данном документе.