

# **INSTALLATION, SERVICE AND MAINTENANCE INSTRUCTIONS**

## **PROLAC HCP**

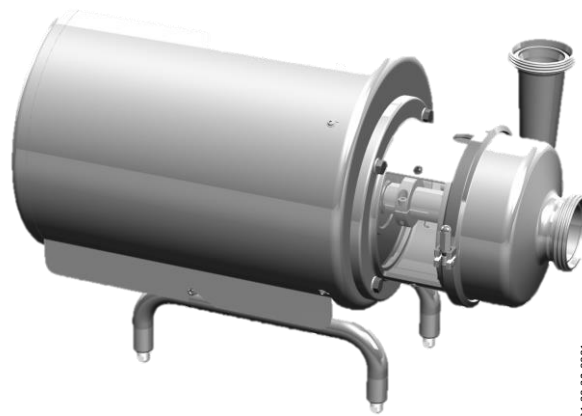

c/Telers, 54 Apto. 174  
E-17820 Banyoles  
Girona (Spain)



Original Manual

01.030.30.01EN

(0) 2012/09

## EC Declaration of Conformity

The manufacturer:

c/ Telers, 57  
17820 Banyoles (Girona), Span

herewith declares that the machine:

### **PROLAC HCP centrifugal pump**

with the serial number: \_\_\_\_\_

conforms to the relevant provisions of the following directives:

Machinery Directive 2006/42/EC (RD 1644/2008)  
Low voltage Directive 2006/95/EC  
Electromagnetic Compatibility Directive 2004/108/EC

Applicable harmonised Standards:

UNE-EN ISO 12100:2012  
UNE-EN 809:1999+A1:2010

In compliance with Regulation (EC) 1935/2004, relating to materials and articles intended to come into contact with food, the materials in contact with the product do not transfer their constituents to the product in quantities which could endanger human health.

Identification of the person empowered to draw up the Declaration on behalf of the manufacturer, and qualified to compile the technical file established by the Community:

Banyoles, 21 September 2014

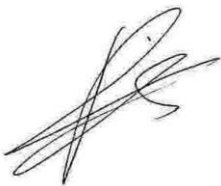

David Reyer Brunet  
Technical Office Manager

---

# 1. Safety

## 1.1. INSTRUCTION MANUAL

This manual contains information regarding the reception, installation, operation, assembly, disassembly and maintenance of the PROLAC HCP pump.

The information published in the instruction manual is based on updated data.

INOXPA reserves the right to modify this instruction manual without prior notice.

## 1.2. INSTRUCTIONS FOR START-UP

This instruction manual contains essential and useful information for the correct handling and maintenance of your pump.

Carefully read the instructions prior to starting the pump, familiarise yourself with the installation, operation and correct use of the pump and strictly follow the instructions. These instructions should be kept in a safe location near the installation area.

## 1.3. SAFETY

### 1.3.1. Warning symbols



Safety hazard for people in general



Danger of injury caused by rotating equipment parts



Electric hazard



Danger! Caustic or corrosive agents.



Danger! Suspended loads



Danger for the correct operation of the equipment



Mandatory to ensure safety at the workplace



Mandatory use of safety goggles

## 1.4. GENERAL SAFETY INSTRUCTIONS



Read the instruction manual carefully before installing and starting the pump. Contact INOXPA in case of doubt.

### 1.4.1. During the installation



The *Technical Specifications* of Chapter 8 should always be observed.

Never start the pump before connecting it to the lines.

Do not operate the pump if the pump cover is not fitted.

Check for proper specifications of the motor, especially if its working conditions create an explosion hazard.



During the installation, all the electric work should be carried out by authorised personnel.

---

### 1.4.2. During operation



The *Technical Specifications* of Chapter 8 should always be observed. Under no circumstances can the specified limit values be exceeded.

NEVER touch the pump or the pipework during operation if the pump is being used for transferring hot liquids or during cleaning.



The pump contains moving parts. Never place your fingers inside the pump during operation.



NEVER operate with the suction and discharge valves closed.

NEVER spray water directly on the electrical motor. The standard motor protection is IP-55: protection against dust and water spray.

### 1.4.3. During maintenance



The *Technical Specifications* of Chapter 8 shall always be observed.

NEVER disassemble the pump until the pipes have been emptied. Remember that liquid will remain inside the pump's body (if does not have a purge). Bear in mind that the pumped liquid may be hazardous or extremely hot. Consult the regulations in effect in each country for these cases.

Do not leave loose parts on the floor.



ALWAYS disconnect the electrical power to the pump prior to carrying out any maintenance. Remove the fuses and disconnect the cables from the motor's terminals.

All electrical work must be carried out by authorised personnel.

### 1.4.4. Compliance with the instructions

Not following the instructions may impose a risk for the operators, the environment and the machine, and may result in the loss of the right to claim damages.

This non-compliance may result in the following risks:

- Failure of important machine/plant functions.
- Failure of specific maintenance and repair procedures.
- Possible electrical, mechanical and chemical hazards.
- Risk to the environment due to the type of substances released.

### 1.4.5. Warranty

Any warranty will be void immediately and lawfully; additionally, INOXPA will be compensated for any civil liability claims submitted by third parties, in the following cases:

- The service and maintenance work have not been carried out in accordance with the service instructions, the repairs have not been carried out by our personnel or have been carried out without our written authorisation;
- Modifications have been carried out on our material or equipment without written authorisation;
- The parts or lubricants used are not INOXPA genuine parts;
- The material or equipment has been improperly used, has been used negligently, or has not been used according to the instructions and their intended;
- The pump parts are damaged because they have been subjected to high pressure due to not having used a safety valve.

The General Conditions of Delivery already in your possession are also applicable.



The machine may not undergo any modification without prior approval from the manufacturer. For your safety, only use original spare parts and accessories.

The usage of other parts will relieve the manufacturer of any liability.

Changing the service conditions can only be carried out with prior written authorisation from INOXPA

Please do not hesitate to contact us in case of doubts or if further explanations are required regarding specific data (adjustments, assembly, disassembly, etc.).

---

## 2. Table of contents

<b>1. Safety</b>	
1.1. Instruction manual.....	3
1.2. Instructions for start-up.....	3
1.3. Safety.....	3
1.4. General safety instructions.....	3
<b>2. Table of contents</b>	
<b>3. General Information</b>	
3.1. Description.....	7
3.2. Application.....	7
<b>4. Installation</b>	
4.1. Reception of the pump.....	8
4.2. Transport and storage.....	9
4.3. Location.....	9
4.4. Pipes.....	9
4.5. Pressurization tank.....	9
4.6. Electrical installation.....	10
<b>5. Starting the pump</b>	
5.1. Start-up.....	11
<b>6. Operating problems</b>	
<b>7. Maintenance</b>	
7.1. General considerations.....	14
7.2. Storage.....	14
7.3. Cleaning.....	14
7.4. Assembly / disassembly of the pump.....	16
<b>8. Technical Specifications</b>	
8.1. Technical Specifications.....	20
8.2. Noise level.....	21
8.3. Tightening torques.....	21
8.4. Cross section PROLAC HCP.....	22
8.5. Double mechanical seal PROLAC HCP.....	22
8.6. PROLAC HCP parts list.....	23

---

## 3. General Information

### 3.1. DESCRIPTION

PROLAC HCP is a range of close-coupled centrifugal pumps with hygienic design, suitable for use in the dairy, beverage, and food industry in general.

This single-stage horizontal pump has a circular body with axial suction and tangential discharge. The main pump components are: body, impeller, cover, lantern and a shaft which is rigidly coupled to the motor shaft.

The standard IEC motor of type IM B35 is protected by a stainless steel shroud and provided with height adjustable stainless steel legs.

### 3.2. APPLICATION

As a general rule, PROLAC HCP pumps in their standard version are used in the food industry mainly to transfer liquids.

For each type of the pump, the hydraulic performance is given by the choice of impeller diameters and speeds. The characteristic curves also show the power and NPSH requirements. The intended use of the pump is defined by its characteristic curve and operating limits provided in the Technical Specifications section.



Misuse of the pump or its use beyond the operating limits may be dangerous or cause permanent damage to the equipment.

# 4. Installation

## 4.1. RECEPTION OF THE PUMP



INOXPA will not be liable for any deterioration of the material due to transport or unpacking. Visually check that the packaging has not been damaged.

The following documentation is included with the pump:

- Shipping documents.
- Instructions and Servicing manual for the pump.
- Instructions and Servicing manual for the motor (\*).
- (\*) If the pump has been supplied with a motor from INOXPA.

Unpack the pump and check the following:

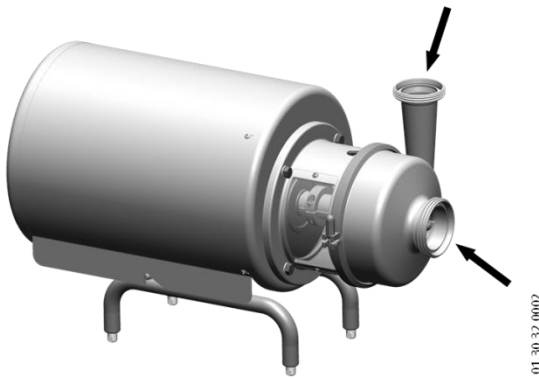

- The suction and discharge connections on the pump, removing any remaining packaging material.
- Check that the pump and motor have not suffered any damage.
- If not in good material condition and/or if not all the parts are included, the shipping carrier should submit a report as soon as possible.

### 4.1.1. Identification of the pump

Each pump has a nameplate with the basic data required to identify the model.

01.30.32.0003

INOXPA S.A.  
C. Telers, 54 · P.O. BOX 174  
17820 BANYOLES · GIRONA (SPAIN)  
Tel. 972 57 52 00 · Fax 972 57 55 02

CE

TIPO  AÑO

N°  ← Serial number

KW  min<sup>-1</sup>  V  Hz

QM<sup>3</sup>/h  Hm  øRODETE

Pump plate



---

## 4.2. TRANSPORT AND STORAGE



The PROLAC HCP pumps are often too heavy to be stored manually.

Lift the pump as indicated below:

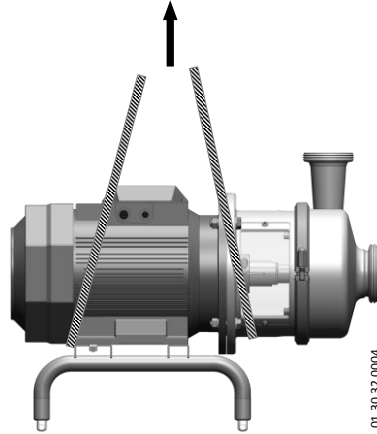

### ATTENTION!

Always remove the motor shroud before hoisting.

## 4.3. LOCATION

Place the pump in a position that allows enough space around it to provide access to the pump as well as to the motor. (Refer to Section 8. *Technical Specifications* for dimensions and weights.)

Place the pump on a flat and level surface.



Install the pump so that it can be properly ventilated.

If the pump is installed outdoors, it must be sheltered under a roof. Its location must allow for easy access during any inspection or maintenance tasks.

## 4.4. PIPES

- As a general rule, install the suction and discharge lines in straight sections, with the minimum possible number of elbows and fittings in order to reduce any pressure losses that may be caused by friction.
- Make sure that the pump's ports are properly aligned with the pipework and have a diameter similar to that of the pump connections.
- Place the pump as close as possible to the suction tank and whenever possible below the liquid level, or even below the tank level in order to achieve the largest possible static head for suction.
- Install support brackets for the lines as close as possible to the pump's suction and discharge ports.

### 4.4.1. Shut-off valves

The pump may be isolated for maintenance. To accomplish this, shut-off valves must be installed and connected to the pump's suction and discharge connections.

These valves must ALWAYS be open during operation of the pump.

## 4.5. PRESSURIZATION TANK

Models with double mechanical seal may require the installation of a pressurization tank.



ALWAYS install the pressurization tank at a height of between 1 and 2 metres with respect to the pump shaft. See Figure 4.6.1.

ALWAYS connect the coolant inlet to the bottom connection on the seal chamber. The coolant will then exit through the top connection on the chamber. See Figure 4.6.1.

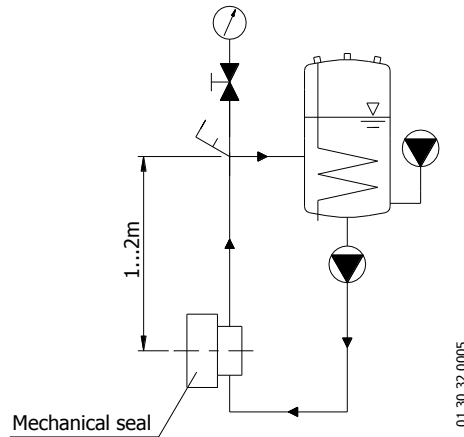

**Figure 4.5.1:** Installation diagram for the pressurization tank

For more information on the pressurization tank (installation, performance, maintenance, etc.), refer to the instruction manual supplied by the manufacturer.

#### 4.6. ELECTRICAL INSTALLATION



Only qualified personnel can connect the electric motors.  
Take the necessary measures to prevent damage to cables and connections.



Electrical equipment, terminals and components of the control systems may still carry current when they are disconnected. Contacting them may impose a hazard to operators or cause irreparable material damage.

Prior to handling the pump, make sure that the electrical panel is disconnected.

- Connect the motor in accordance with the instructions supplied by the motor manufacturer.
- Check the direction of rotation.

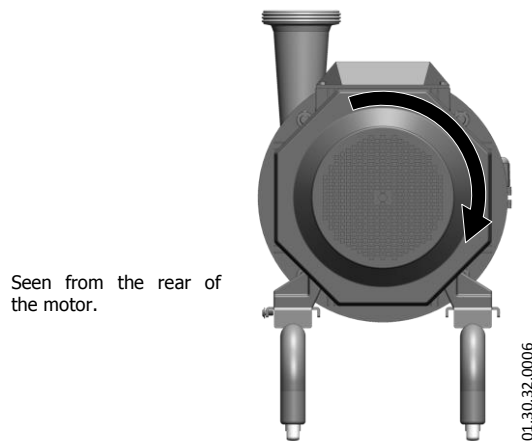

Seen from the rear of the motor.

**ATTENTION!**  
See indicator label on the pump.

Start and stop the pump motor momentarily. Make sure, looking at the pump from behind, that the motor fan rotates in a clockwise direction.



ALWAYS check the direction of rotation of the motor with liquid inside the pump.

For models with a seal chamber, ALWAYS ensure that it is full of liquid prior to checking the direction of rotation.

---

# 5. Starting the pump



Prior to starting the pump, carefully read the instructions in Section 4. *Installation*.

## 5.1. START-UP



Carefully read Section 8. *Technical Specifications*. INOXPA will not be liable for improper use of the equipment.



NEVER touch the pump or the lines if hot liquids are being pumped.

### 5.1.1. Checks before starting the pump

- Completely open the shut-off valves on the suction and discharge lines.
- If liquid does not flow towards the pump, fill it with the liquid to be pumped.



The pump must never turn dry.

- Check that the direction of rotation of the motor is correct.

### 5.1.2. Checks when starting the pump

- Check that the pump is not making any strange noises.
- Check if the absolute inlet pressure is sufficient to prevent cavitation in the pump. Check the curve to obtain the minimum required pressure above the vapour pressure (NPSHr).
- Control the discharge pressure.
- Check for leaks in the sealing areas.



A shut-off valve shall not be used to regulate the flow in the suction line. All shut-off valves must be fully open during operation.



Control the motor consumption to prevent an electrical overload.

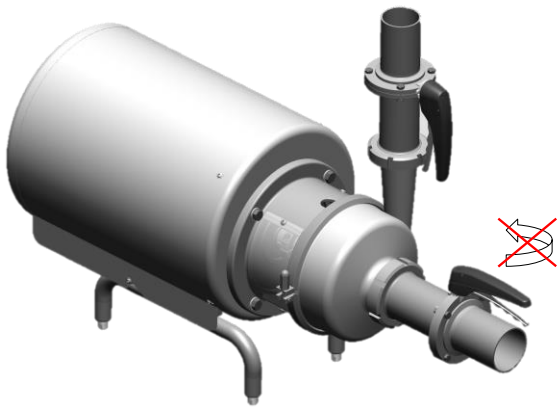

01.30.32.0007

Reduce the flow rate and the electrical power consumed by the motor:

- by regulating the pump's discharge flow.
- by decreasing the motor speed.

# 6. Operating problems

The attached table lists solutions to problems that may arise while operating the pump. It is assumed that the pump has been properly installed and that it has been selected correctly for the specific application. Contact INOXPA if technical assistance is required.

Motor overload																																			
↓	The pump flow or pressure is insufficient.																																		
↓	There is no pressure on the discharge side.																																		
↓	Irregular discharge flow rate / pressure.																																		
↓	Noise and vibrations.																																		
↓	The pump gets clogged.																																		
↓	Pump overheated.																																		
↓	Abnormal wear.																																		
↓	Leak through the mechanical seal.																																		
↓																																			
	<table border="1"> <thead> <tr> <th>PROBABLE CAUSES</th> <th>SOLUTIONS</th> </tr> </thead> <tbody> <tr> <td>Wrong direction of rotation.</td> <td>Reverse the direction of rotation .</td> </tr> <tr> <td>Insufficient NPSH</td> <td>Raise the suction tank. Lower the pump. Reduce the vapour pressure. Widen the diameter of the suction pipe. Shorten and simplify the suction line.</td> </tr> <tr> <td>Pump not purged</td> <td>Purge or fill.</td> </tr> <tr> <td>Cavitation.</td> <td>Increase the suction pressure.</td> </tr> <tr> <td>The pump sucks in air.</td> <td>Check the suction line and all of its connections.</td> </tr> <tr> <td>Suction pipe obstructed</td> <td>Check the suction line and the filters, if available.</td> </tr> <tr> <td>Discharge pressure too high</td> <td>If necessary, reduce the pressure losses, for example, by increasing the pipe diameter.</td> </tr> <tr> <td>Flow rate too high</td> <td>Reduce the flow by means of a diaphragm. Partially close the discharge valve. Trim the impeller. Decrease speed.</td> </tr> <tr> <td>Viscosity of the liquid too high.</td> <td>Reduce the viscosity, for example, by heating the liquid.</td> </tr> <tr> <td>Liquid temperature is too high</td> <td>Decrease the temperature by cooling the liquid.</td> </tr> <tr> <td>Mechanical seal worn or damaged.</td> <td>Replace the seal.</td> </tr> <tr> <td>Inadequate O-rings for the liquid.</td> <td>Install the correct O-rings after consulting the supplier.</td> </tr> <tr> <td>The impeller scrapes</td> <td>Lower the temperature. Reduce the suction pressure. Adjust the impeller/cover play.</td> </tr> <tr> <td>Tension in the lines.</td> <td>Connect the pipes to the pump without tension.</td> </tr> <tr> <td>Foreign matter in the liquid.</td> <td>Install a filter in the suction pipe.</td> </tr> <tr> <td>Mechanical seal spring tension is too low.</td> <td>Adjust as indicated in this manual.</td> </tr> </tbody> </table>	PROBABLE CAUSES	SOLUTIONS	Wrong direction of rotation.	Reverse the direction of rotation .	Insufficient NPSH	Raise the suction tank. Lower the pump. Reduce the vapour pressure. Widen the diameter of the suction pipe. Shorten and simplify the suction line.	Pump not purged	Purge or fill.	Cavitation.	Increase the suction pressure.	The pump sucks in air.	Check the suction line and all of its connections.	Suction pipe obstructed	Check the suction line and the filters, if available.	Discharge pressure too high	If necessary, reduce the pressure losses, for example, by increasing the pipe diameter.	Flow rate too high	Reduce the flow by means of a diaphragm. Partially close the discharge valve. Trim the impeller. Decrease speed.	Viscosity of the liquid too high.	Reduce the viscosity, for example, by heating the liquid.	Liquid temperature is too high	Decrease the temperature by cooling the liquid.	Mechanical seal worn or damaged.	Replace the seal.	Inadequate O-rings for the liquid.	Install the correct O-rings after consulting the supplier.	The impeller scrapes	Lower the temperature. Reduce the suction pressure. Adjust the impeller/cover play.	Tension in the lines.	Connect the pipes to the pump without tension.	Foreign matter in the liquid.	Install a filter in the suction pipe.	Mechanical seal spring tension is too low.	Adjust as indicated in this manual.
PROBABLE CAUSES	SOLUTIONS																																		
Wrong direction of rotation.	Reverse the direction of rotation .																																		
Insufficient NPSH	Raise the suction tank. Lower the pump. Reduce the vapour pressure. Widen the diameter of the suction pipe. Shorten and simplify the suction line.																																		
Pump not purged	Purge or fill.																																		
Cavitation.	Increase the suction pressure.																																		
The pump sucks in air.	Check the suction line and all of its connections.																																		
Suction pipe obstructed	Check the suction line and the filters, if available.																																		
Discharge pressure too high	If necessary, reduce the pressure losses, for example, by increasing the pipe diameter.																																		
Flow rate too high	Reduce the flow by means of a diaphragm. Partially close the discharge valve. Trim the impeller. Decrease speed.																																		
Viscosity of the liquid too high.	Reduce the viscosity, for example, by heating the liquid.																																		
Liquid temperature is too high	Decrease the temperature by cooling the liquid.																																		
Mechanical seal worn or damaged.	Replace the seal.																																		
Inadequate O-rings for the liquid.	Install the correct O-rings after consulting the supplier.																																		
The impeller scrapes	Lower the temperature. Reduce the suction pressure. Adjust the impeller/cover play.																																		
Tension in the lines.	Connect the pipes to the pump without tension.																																		
Foreign matter in the liquid.	Install a filter in the suction pipe.																																		
Mechanical seal spring tension is too low.	Adjust as indicated in this manual.																																		

---

# 7. Maintenance

## 7.1. GENERAL CONSIDERATIONS

This pump, just like any other machine, requires maintenance. The instructions contained in this manual cover the identification and replacement of spare parts. The instructions are aimed at maintenance personnel and those responsible for the supply of spare parts.



Carefully read Chapter 8. *Technical Specifications*.

All replaced material should be duly disposed of/recycled according to the directives in force in each area.



ALWAYS disconnect the pump before beginning any maintenance work.

### 7.1.1. Check the mechanical seal

Periodically check that there are no leaks around the shaft. If leakage is detected through the mechanical seal, replace it following the instructions in the section *Assembly and Disassembly*.

## 7.2. STORAGE

Before storing the pump it should be completely drained. Prevent as far as possible exposing the parts to excessively humid environments.

## 7.3. CLEANING



The use of aggressive cleaning products such as caustic soda and nitric acid may burn the skin.

Use rubber gloves during the cleaning process.



Always use protective goggles.

### 7.3.1. CIP (Clean-in-Place) cleaning

If the pump is installed in a system with a CIP process, its removal will not be required. If an automatic cleaning process is not available, disassemble the pump as indicated in the section *Assembly and Disassembly*.

Cleaning solutions for CIP processes.

Only use clear water (chlorine-free) to mix with the cleaning agents:

**a) Alkaline solution:** 1% by weight of caustic soda (NaOH) at 70°C (150°F)

1 kg NaOH + 100 litres of water = cleaning solution

or

2.2 litres of 33% NaOH + 100 litres of water = cleaning solution

**b) Acid solution:** 0.5% by weight of nitric acid (HNO<sub>3</sub>) at 70°C (150°F)

0.7 litres of 53% HNO<sub>3</sub> + 100 litres of water = cleaning solution



Check the concentration of the cleaning solutions; incorrect concentrations may lead to deterioration of the pump seals.

To remove any traces of cleaning products, ALWAYS perform a final rinse with clean water at the end of the cleaning process.

### 7.3.2. SIP (Sterilization-in-Place) cleaning

Sterilization with steam is applied to all equipment including the pump.



Do NOT use the equipment during the steam sterilization process.

The parts/materials will not be damaged if the indications specified in this manual are observed.

Make sure that no cold liquid enters the system until the temperature of the pump is lower than 60°C (140°F).

The pump generates an important pressure loss through the sterilization process. We recommend the use of a branch circuit with a discharge valve to ensure that steam / superheated water sterilizes the integrity of the circuit.

Maximum conditions during the SIP process with steam or overheated water

- a) **Max. temperature:** 140°C / 284°F
- b) **Max. time:** 30 min.
- c) **Cooling:** Sterile air or inert gas
- d) **Materials:** EPDM  
FPM

## 7.4. ASSEMBLY / DISASSEMBLY OF THE PUMP

### 7.4.1. Pump and single mechanical seal

#### ⇒ Disassembly

1. Remove the clamping ring (15) and disassemble the pump casing (01).
2. Check the condition of the O-ring (80) on the pump body and replace if damaged.

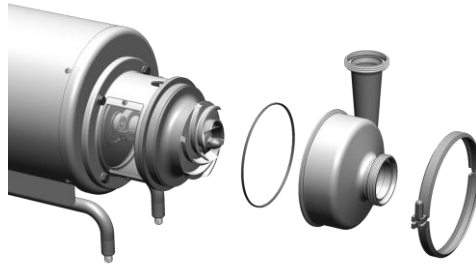

01.30.32.0008

3. Remove the screws (50) and the lantern protections (47).
4. Place an open-end wrench on the flat sides of the shaft (05) to prevent it from rotating.
5. Remove the impeller nut (45) and the O-ring (80A).
6. Pull out the impeller (02). If necessary, hit it with a dead blow using a plastic mallet in order to disengage the cone.
7. Remove the rotating part of the seal (08) from the rear side of the impeller (02).
8. Manually remove the stationary part of the seal (08) which is located in the pump cover (03).

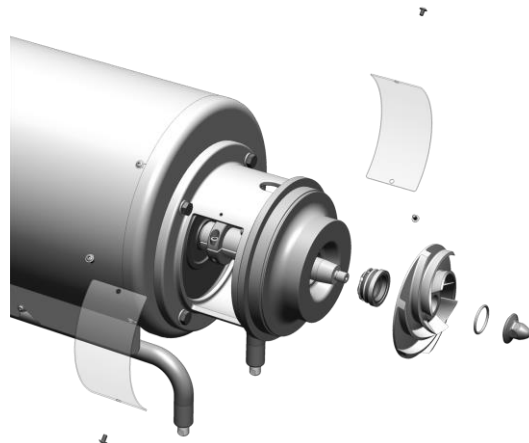

01.30.32.0009

9. If the thrust washer and the seal spring need to be replaced, loosen the Allen screws (51A) that secure the pump cover (03) and take it off. Then loosen the Allen screws (51) and remove the seal cover (09).
10. Check the spring and the thrust washer on the mechanical seal (08) and replace if necessary.

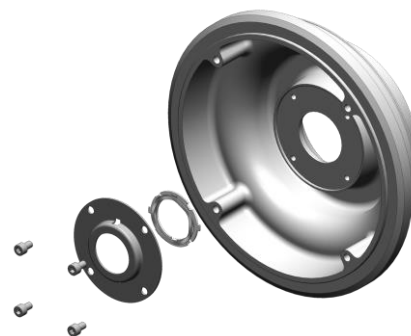

01.30.32.0010



## ← Assembly

1. Place the thrust washer of the mechanical seal (08) on the pump cover (03). Make sure that the four tabs centring the spring are facing outward.
2. Fit the spring on the thrust washer within the centring tabs. Place the seal cover (09) on the assembly and move it until the seal washer thrust tabs match the slots on the cover (09). Secure it with the Allen screws (51).

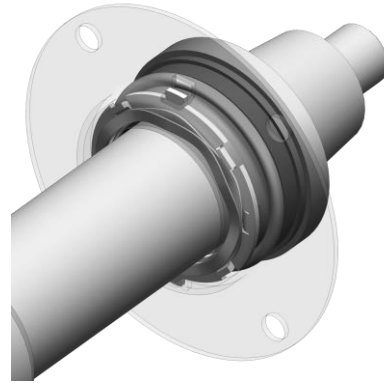

01.30.32.0011

3. Mount the pump cover (03) on the lantern (04) and secure it with the screws (51A).
4. Fit the stationary part of the seal (08) on the pump cover (03) with the fingers. Make sure that the anti-rotation tabs match the slots on the seal.
5. Fit the rotating part of the mechanical seal (08) on the rear side of the impeller (02) and make sure that it is level.
6. Place the O-ring (80A) in the slot of the impeller nut (45).
7. Place an open-end wrench on the flat sides of the shaft (05) to prevent it from rotating.
8. Insert the impeller (02) on the pump shaft (05) and secure with the nut (45).

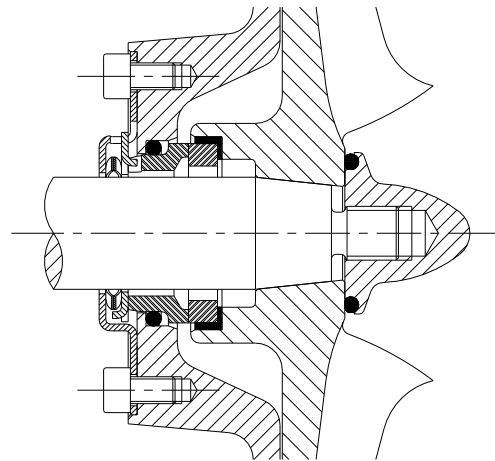

01.30.32.0012

**ATTENTION! When installing the new seal, use soapy water when fitting the different parts and gaskets to allow them to slide better; apply to the stationary as well as the rotating parts.**

### 7.4.2. Double mechanical seal

#### ⇒ Disassembly

1. Remove the main seal following the instructions in the section [Disassembly of the single mechanical seal](#) up to point 8.
2. Loosen the Allen screws (51A) and carefully remove the pump cover (03) taking care not to damage the stationary part of the secondary seal located therein.
3. Loosen the Allen screws (51B) and remove the double seal cover (10) together with the stationary part of the secondary seal of the pump cover (03). Remove the spring and thrust washers.
4. Manually remove the stationary part of the secondary seal (08) which is located in the double seal cover (10) as well as the O-ring (80C).
5. Loosen the set screw (55) and remove the double seal ring (30) on the shaft (05) along with the rotating part of the secondary seal.
6. Remove the rotating part of the secondary seal and the O-ring (80D) from the double seal ring.

## ← Assembly

1. Install the rotating part of the new secondary seal and the O-ring (80) on the double seal ring (30). Slide the assembly over the pump shaft (05).
2. Fit the stationary part of the secondary seal (08) and the O-ring (80C) with your fingers on the double seal cover (10).
3. Place the thrust washer of the primary seal (08) on the pump cover (03). Make sure that the four tabs centring the spring are facing outward.
4. Fit the spring on the thrust washer within the centring tabs. Place the thrust washer of secondary seal on the spring. Make sure that the four tabs centring the spring are pointing inward.
5. Place the double seal cover (10) together with the secondary stationary part and the O-ring (80C) on the pump cover (03) and move it until the thrust tabs on the washers of the primary and secondary seals match the slots on the slots on the stationary part of the secondary seal. Secure it with the Allen screws (51B).
6. Mount the assembly of the pump cover (03) and the stationary part of the secondary seal to the lantern (04) and fasten with the screws (51A).
7. Slide the double seal ring (30) onto the shaft (05), checking that the distances between the ring and the double seal cover are as shown below, and tighten the set screw (55).

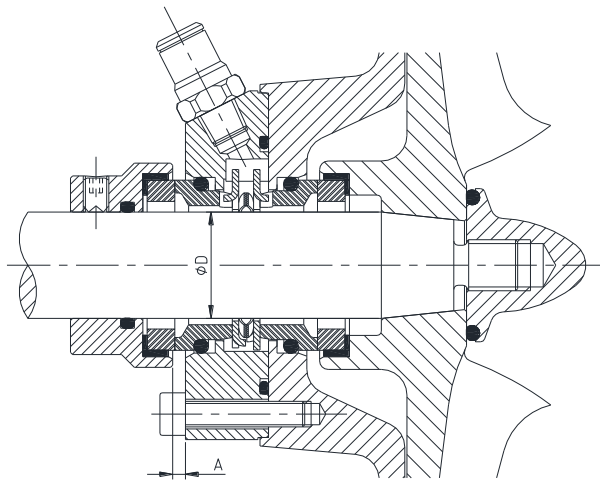

$\varnothing D$	A
25	3
35	3.5

01.30.32.0013

8. Install the primary seal following the assembly instructions for the single mechanical seal starting at point 4.

**ATTENTION! When installing the new seal, use soapy water when fitting the different parts and gaskets to allow them to slide better; apply to the stationary parts on the cover as well as the rotating parts on the impeller and the double seal ring.**

### 7.4.3. Installation and adjustment of the shaft

#### ⇒ Disassembly

1. Loosen the Allen screw (51E) on the shaft clamp (17).
2. Remove the shaft (05) along with the clamp (17).

#### ← Assembly

1. Mount the pump shaft (05) with the clamp (17) on the motor shaft.
2. Tighten the Allen screw (51E) on the clamp only slightly and check that the pump shaft (05) can still turn. Make sure to fit the shaft clamp (17) as shown in the figure.

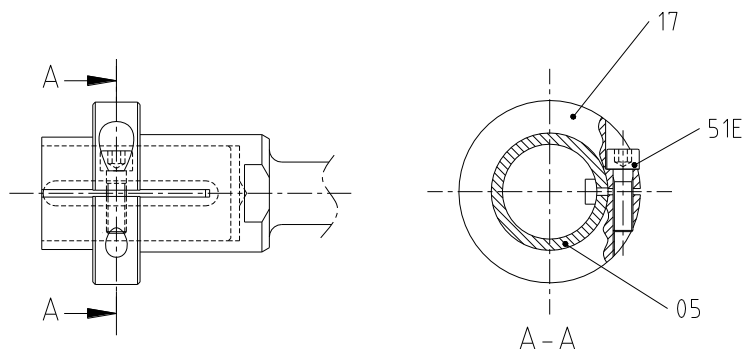

**ATTENTION! Apply assembly grease on the thread and on the head of the clamp screw.**

3. Fit the cover (03), the screws (51A) and tighten them.
4. Install the impeller (02) on the pump shaft and secure it with the lock nut (45). Place an open-end wrench on the flat sides of the shaft to prevent it from rotating.
5. Slide the impeller with the shaft (05) until it reaches the pump cover (03).
6. Install the body (01) and secure it with the clamp (15).
7. With the help of a thickness gauge, move the pump shaft so that the impeller is located at the required distance B from the body (01). 0.4 mm for 40-110, 40-150, 50-150, 65-175 and 80-175, and 0.5 mm for the rest.

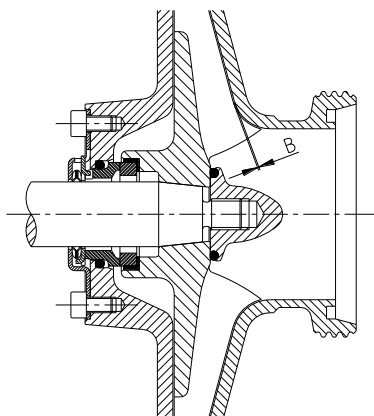

8. Tighten the Allen screw (51E) on the shaft clamp.
9. Remove the body (01), the impeller (02) and the cover (03), and continue with the assembly of the mechanical seal.

---

# 8. Technical Specifications

## 8.1. TECHNICAL SPECIFICATIONS

Maximum operating pressure	1600 kPa (16 bar)
Temperature range	-10 to 120 °C (EPDM)
Maximum speed	3000 rpm (50 Hz) 3600 rpm (60 Hz)
Noise level	61 to 80 dB (A) (see table for different models)

### Materials

Parts in contact with the product	AISI 1.4404
Other steel parts	AISI 304 L (1.4306)
Gaskets in contact with the product	EPDM (standard) FPM (other materials available upon request)
Other gaskets	NBR
Exterior surface finish	Matt
Interior surface finish	Polished Ra<0,8 µm

### Mechanical seal

Type	Internal single or double seal, balanced
Material of rotating part	Silicon carbide (SiC) (standard)
Material stationary part	Graphite (C) (standard) Silicon carbide (SiC)
Gasket material	EPDM (standard) FPM
Water consumption (double seal)	0.25 to 0.6 l/min
Pressure (double seal)	from atmospheric to 1000 kPa (10 bar)

### Motor

Type	Three-phase asynchronous motor, IEC B35 type, 2 or 4 poles, IP55 protection, Class-F insulation
Power	0.37 to 45 kW
Voltage and frequency	220-240 V Δ / 380-420 V Y, ≤ 4 kW 380-420 V Δ / 660-690 V Y, ≥ 5.5 kW

---

## 8.2. NOISE LEVEL

The indicated noise levels correspond to the standard pump, with maximum impeller and shrouded motor, running at approx. 2900 rpm, at the point of best efficiency and with a motor with sufficient power.

These values were taken at a distance of 1 m from the pump and at a height of 1.6 m above the floor level. The measurements were carried out according to the standard EN 12639 / ISO 3746 Grade 3 with a tolerance of  $\pm 3\text{dB (A)}$ .

Pump type	Sound pressure LpA dB(A)	Sound power LwA dB(A)
HCP 40-110	61	74
HCP 40-150	63	75
HCP 40-205	70	84
HCP 50-150	71	84
HCP 50-260	78	92
HCP 50-190	70	84
HCP 65-175	72	85
HCP 65-215	78	92
HCP 65-250	79	93
HCP 80-175	77	90
HCP 80-205	80	94
HCP 80-240	77	91

It must be borne in mind that the noise levels can greatly increase if reducers, elbows or other fittings are installed near the pump.



When the sound pressure level in the operating area exceeds 80 dB(A), appropriate personal protective equipment must be used.

## 8.3. TIGHTENING TORQUES

If not stated otherwise, the torques listed in the following table should be applied on the nuts and bolts of this pump.

Size	Nm	lbf·ft
M6	10	7
M8	21	16
M10	42	31
M12	74	55
M16	112	83

### 8.4. CROSS SECTION PROLAC HCP

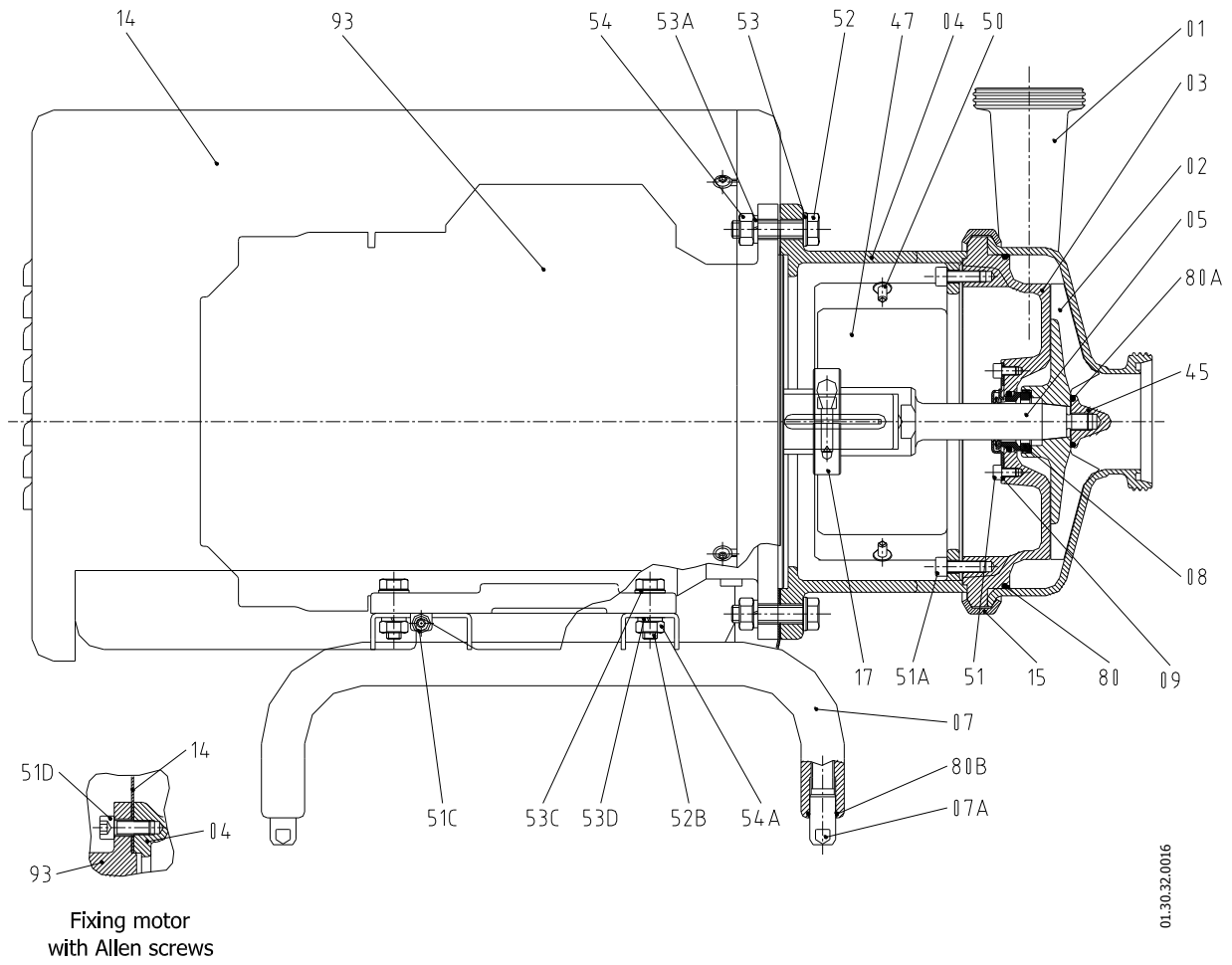

### 8.5. DOUBLE MECHANICAL SEAL PROLAC HCP

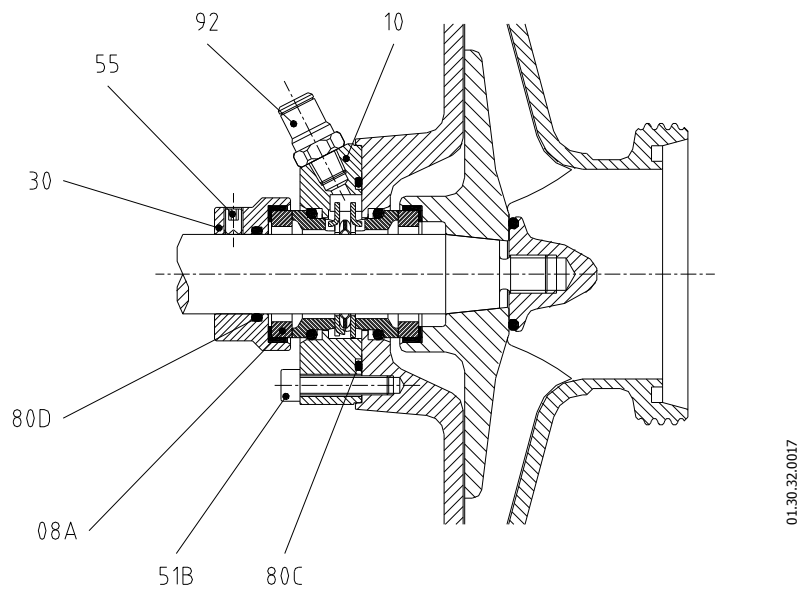

## 8.6. PROLAC HCP PARTS LIST

Position	Description	Quantity	Material
01	Body	1	AISI 316L
02	Impeller	1	AISI 316L
03	Pump cover	1	AISI 316L
04	Lantern	1	AISI 304
05	Shaft	1	AISI 316L
07	Motor leg	2	AISI 304
07A	Adjustable leg	4	AISI 304
08	Mechanical seal	1	-
09	Seal cover	1	AISI 316L
14	Shroud	1	AISI 304
15	Clamp body	1	AISI 304
17	Clamp motor	1	AISI 304
45	Cap nut	1	AISI 316L
47	Lantern protection	2	PETP
50	Protector screw	4	A2
51	Allen screw	4	A2
51A	Allen screw	4	A2
51C	Oval-head Allen screw	2	A2
51D	Allen screw	4	A2
52	Hexagonal screw	4	A2
52B	Hexagonal screw	4	A2
53	Flat washer	4	A2
53A	Grower washer	4	A2
53C	Flat washer	4	A2
53D	Grower washer	4	A2
54	Hexagonal nut	4	A2
54A	Hexagonal nut	4	A2
80	O-ring	1	EPDM
80A	O-ring	1	EPDM
80B	O-ring	4	EPDM
93	Motor	1	-

08A	Double mechanical seal	1	-
10	Double seal cover	1	AISI 316L
30	Double seal ring	1	AISI 316L
51B	Allen screw	4	A2
55	Stud	1	A2
80C	O-ring	1	EPDM
80D	O-ring	1	EPDM
92	Straight connector 1/8" BSPT D.8	2	AISI 316

---

## Насосы — Центробежный Насос Prolac НСР-WFI

<http://k-tep.com.ua/>

✉ [k-tep@ukr.net](mailto:k-tep@ukr.net)

■ МТС +38 066 9076563

■ Киевстар +38 098 3676414

Skype: [k-teppumps](#)

### Замечания

*Условия поставки: DDP склад г. Киев*

#### Заметки

Время поставки рассчитано согласно дате предложения и изменяется в зависимости от даты подтверждения заказа.

Помещая заказ, Покупатель принимает предложение и все спецификации, характеристики и условия, указанные в данном документе.