

**ИНСТРУКЦИЯ ПО УСТАНОВКЕ И ТЕХНИЧЕСКОМУ
ОБСЛУЖИВАНИЮ
Центробежный насос Prolac HCP SP**

**INSTALLATION, SERVICE AND MAINTENANCE
INSTRUCTIONS
PROLAC HCP SP**



c/Telers, 54 Apto. 174
E-17820 Banyoles
Girona (Spain)

01.31.32.0001



Original Manual

01.031.30.01EN

(0) 2013/09

EC DECLARATION OF CONFORMITY

The manufacturer:

c/ Telers, 57
17820 Banyoles (Girona), Spain

herewith declares that the machine:

PROLAC HCP SP centrifugal pump

with the serial number: _____

conforms to the relevant provisions of the following directives:

Machinery Directive 2006/42/EC (RD 1644/2008)
Low voltage Directive 2006/95/EC
Electromagnetic Compatibility Directive 2004/108/EC

Applicable harmonised Standards:

UNE-EN ISO 12100:2012
UNE-EN 809:1999+A1:2010

In compliance with Regulation (EC) 1935/2004, relating to materials and articles intended to come into contact with food, the materials in contact with the product do not transfer their constituents to the product in quantities which could endanger human health.

Identification of the person empowered to draw up the Declaration on behalf of the manufacturer, and qualified to compile the technical file established by the Community:

Banyoles, 20 September 2013

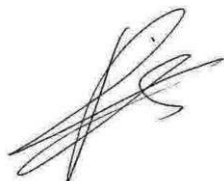

David Reyer Brunet
Technical Office Manager

1. Safety

1.1. INSTRUCTION MANUAL

This manual contains information regarding the reception, installation, operation, assembly, disassembly and maintenance of the PROLAC HCP SP pump.

The information published in the instruction manual is based on updated data.

INOXPA reserves the right to modify this instruction manual without prior notice.

1.2. INSTRUCTIONS FOR START-UP

This instruction manual contains essential and useful information for the correct handling and maintenance of your pump.

Carefully read the instructions prior to starting the pump, familiarise yourself with the installation, operation and correct use of the pump and strictly follow the instructions. These instructions must be kept in a safe location near the installation area.

1.3. SAFETY

1.3.1. Warning symbols



Danger for people in general



Danger of injury caused by rotating equipment parts



Electrical hazard



Danger! Caustic or corrosive agents



Danger! Suspended loads



Danger to the correct operation of the equipment



Mandatory to ensure safety at the workplace



Mandatory use of safety goggles

1.4. GENERAL SAFETY INSTRUCTIONS



Read the instruction manual carefully before installing and starting the pump. Contact INOXPA in case of doubt.

1.4.1. During the installation



The *Technical Specifications* in Chapter 8 must always be observed.

Never start the pump before connecting it to the pipes.

Do not operate the pump if the pump cover is not fitted.

Check for correct specifications of the motor, especially if its working conditions create an explosion hazard.



During the installation, all the electrical work must be carried out by authorised personnel.

1.4.2. During operation



The *Technical Specifications* in Chapter 8 must always be observed. Under no circumstances can the specified limit values be exceeded.

NEVER touch the pump or the pipework during operation if the pump is being used for transferring hot liquids or during cleaning.



The pump contains moving parts. Never place your fingers inside the pump during operation.



NEVER operate with the suction and discharge valves closed.

NEVER spray water directly on the electrical motor. The standard motor protection is IP-55: protection against dust and water spray.

1.4.3. During maintenance



The *Technical Specifications* in Chapter 8 must always be observed.

NEVER disassemble the pump until the pipes have been emptied. Remember that liquid will always remain inside the pump's body (if does not have a purge). Bear in mind that the liquid being pumped may be hazardous or extremely hot. Consult the regulations in effect in each country for these cases.

Do not leave loose parts on the floor.



ALWAYS disconnect the electrical power to the pump prior to carrying out any maintenance. Remove the fuses and disconnect the cables from the motor terminals.

All electrical work must be carried out by authorised personnel.

1.4.4. Compliance with the instructions

Any failure to comply with the instructions may impose a risk to the operators, the environment and the machine, and may ultimately result in the loss of the right to claim damages.

This non-compliance may result in the following risks:

- Failure of important machine/plant functions.
- Failure of specific maintenance and repair procedures.
- Possible electrical, mechanical and chemical hazards.
- Risk to the environment due to the type of substances released.

1.4.5. Warranty

Any warranty will be void immediately and lawfully; additionally, INOXPA shall be compensated for any civil liability claims submitted by third parties, in the following cases:

- The service and maintenance work have not been carried out in accordance with the service instructions, the repairs have not been carried out by our personnel or have been carried out without our written authorisation.
- Modifications have been carried out on our material or equipment without written authorisation.
- The parts or lubricants used are not INOXPA genuine parts.
- The material or equipment has been improperly used, has been used negligently, or has not been used according to the instructions and their intended.

-
- The pump parts are damaged because they have been subjected to high pressure due to not having used a safety valve.

The General Terms of Delivery already in your possession are also applicable.



The machine may not undergo any modification without prior approval from the manufacturer. For your safety, only use original spare parts and accessories.

The usage of other parts will relieve the manufacturer of any liability.

Changing the service conditions can only be carried out with prior written authorisation from INOXPA

Please do not hesitate to contact us in case of doubts or if further explanations are required regarding specific data (adjustments, assembly, disassembly, etc.).

2. Table of contents

1. Safety	
1.1. Instruction manual.....	3
1.2. Instructions for start-up.....	3
1.3. Safety	3
1.4. General safety instructions.....	3
Manual de instrucciones.....	5
2. Table of contents	
3. General Information	
3.1. Description.....	7
3.2. Application	7
3.3. Operating principle.....	7
4. Installation	
4.1. Reception of the pump	8
4.2. Handling and storage	9
4.3. Location.....	9
4.4. Pipes	9
4.5. Pressurization tank.....	9
4.6. Electrical installation.....	10
5. Starting the pump	
5.1. Starting the pump.....	11
6. Operating problems	
7. Maintenance	
7.1. General considerations	14
7.2. Storage.....	14
7.3. Cleaning.....	14
7.4. Disassembly / Assembly of the pump.....	16
8. Technical Specifications	
8.1. Technical Specifications.....	21
8.2. Noise level	22
8.3. Tightening torques.....	22
8.4. Cross section PROLAC HCP SP.....	23
8.5. Double mechanical seal PROLAC HCP SP.....	23
8.6. PROLAC HCP SP parts list	24

3. General Information

3.1. DESCRIPTION

The PROLAC HCP SP has the same components as the PROLAC HCP. The key difference between the two pumps is the body. The impeller, seal and all the other parts are the same in both pumps.

The body of the PROLAC HCP SP includes a separator tank and a non-return valve, ensuring high levels of efficiency.

The IM B35 type motor complies with the IEC standards and is protected by a stainless steel shroud and provided with height adjustable stainless steel legs.

3.2. APPLICATION

Due to its design and choice of materials, the PROLAC HCP SP is suitable for applications requiring a high level of hygiene, gentle handling of the product and resistance to chemical agents.

The HCP SP pump is particularly suitable for pumping liquids containing air or gas without losing its pumping capacity. It can be used in the food-processing, pharmaceutical and chemical industries. Its main application is the return of the CIP cleaning system.

For each type of the pump, the hydraulic performance is given by the choice of impeller diameters and speeds. The characteristic curves also show the power and NPSH requirements. The intended use of the pump is defined by its characteristic curve and operating limits provided in the Technical Specifications section.

3.3. OPERATING PRINCIPLE

The PROLAC HCP SP is a self-priming pump that eliminates the need for a vacuum pump or other devices such as foot valves or additional pipes.

The pump needs to be filled with liquid only once before starting it up. When the pump is turned on, it sucks the air or gas present in the suction pipe, mixing it with the liquid in the pump body. The centrifugal force pushes the mixture of liquid and gas towards the separator tank where it loses speed. Because of gravity, the liquid remains at the bottom of the separator tank and is driven back to the pump body through the return pipe, while the air or gas is released through the discharge pipe. In this way, the air or gas is continuously being removed from the suction pipe until the liquid reaches the pump body and the pump begins to operate like a normal centrifugal pump.

It is very important the sucked air is released through the discharge pipe without any backpressure.

It is not advisable to reduce the hydraulic performance of the pump by resizing the impeller or lowering the speed by means of a frequency converter, since it will have negative repercussions on the pump's suction capacity.



Misuse of the pump or its use beyond the operating limits may be dangerous or cause permanent damage to the equipment.

4. Installation

4.1. RECEPTION OF THE PUMP



INOXPA will not be liable for any deterioration of the material due to transport or unpacking. Visually check that the packaging has not been damaged.

The following documentation is included with the pump:

- Shipping documents
- Instructions and Servicing manual for the pump.
- Instructions and Servicing manual for the motor (*).
- (*) If the pump has been supplied with a motor from INOXPA.

Unpack the pump and check the following:

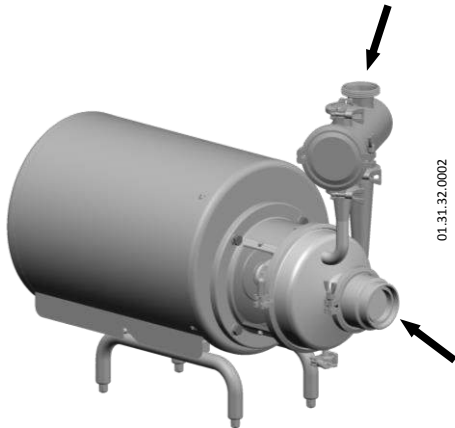

- The suction and discharge connections on the pump, removing any remaining packaging material.
- Check that the pump and motor have not suffered any damage.
- If not in good material condition and/or if not all the parts are included, the shipping carrier should submit a report as soon as possible.

4.1.1. Identification of the pump

Each pump has a nameplate with the basic data required to identify the model.

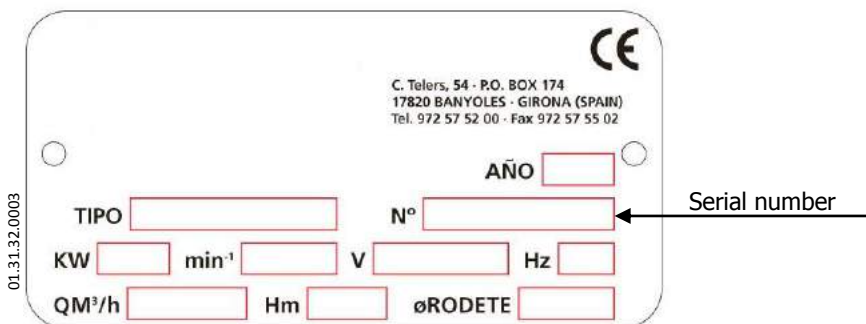

Pump plate

4.2. HANDLING AND STORAGE



The PROLAC HCP SP pumps are often too heavy to be stored manually.

Lift the pump as indicated below:

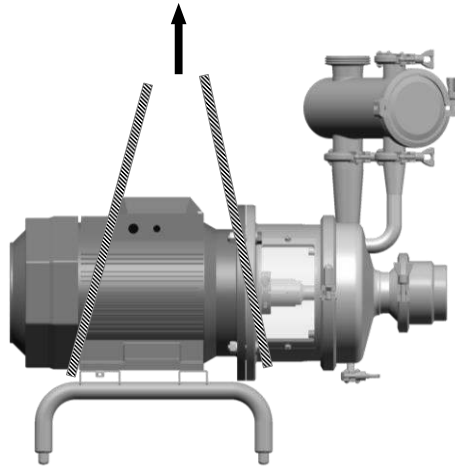

ATTENTION!

Always remove the motor shroud before hoisting.

01.30.32.0004

4.3. LOCATION

Place the pump in a position that allows enough space around it to provide access to the pump as well as to the motor. (Refer to Chapter 8. *Technical Specifications* for dimensions and weights).

Place the pump on a flat and level surface.



Install the pump so as to allow proper ventilation.

If the pump is installed outdoors, it must be sheltered under a roof. Its location must allow for easy access during any inspection or maintenance tasks.

4.4. PIPES

- As a general rule, install the suction and discharge pipes in straight sections, with the minimum possible number of bends and fittings in order to reduce as much as possible any pressure losses that may be caused by friction.
- Make sure that the pump's ports are properly aligned with the pipework and have a diameter similar to that of the pump connections.
- Install support brackets for the pipes as close as possible to the pump's suction and discharge ports.

4.4.1. Shut-off valves

The pump may be isolated for maintenance. To accomplish this, shut-off valves must be installed and connected to the pump's suction and discharge connections.

These valves must ALWAYS be open during operation of the pump.

4.5. PRESSURIZATION TANK

Models with double mechanical seal may require the installation of a pressurization tank.



ALWAYS install the pressurization tank at a height of between 1 and 2 metres with respect to the pump shaft. See Figure 4.6.1.

ALWAYS connect the coolant inlet to the bottom connection of the seal chamber. The coolant will then exit through the top connection of the chamber. See Figure 4.6.1.

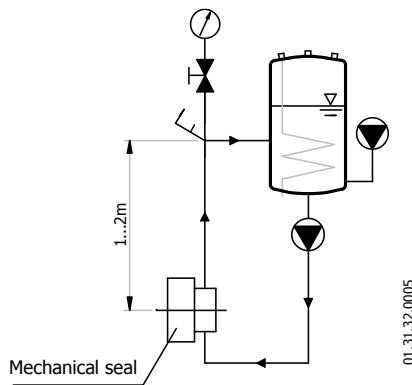

Figure 4.5.1: Installation diagram for the pressurization tank

For more information on the pressurization tank (installation, operation, maintenance, etc.), refer to the instruction manual supplied by the manufacturer.

4.6. ELECTRICAL INSTALLATION



The connection of the electrical motors must be performed by qualified personnel. Take the necessary precautions to prevent damage to cables and connections.



Electrical equipment, terminals and components of the control systems may still bear electrical current when they are disconnected. Contact with them may be dangerous for operators or cause irreversible damage to equipment.

Prior to handling the pump, make sure that the electrical panel is disconnected.

- Connect the motor in accordance with the instructions supplied by the motor manufacturer.
- Check the direction of rotation.

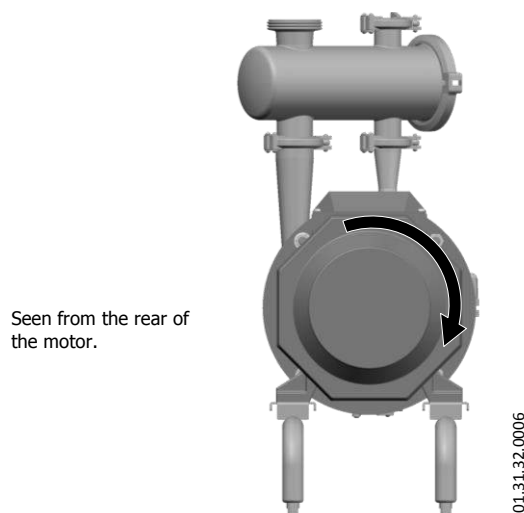

ATTENTION!
See indicator label on the pump.

Start and stop the pump motor momentarily. Make sure, looking at the pump from behind, that the motor fan rotates in a clockwise direction.



ALWAYS check the direction of rotation of the motor with liquid inside the pump.

For models with a seal chamber, **ALWAYS** ensure that it is full of liquid prior to checking the direction of rotation.

5. Starting the pump



Prior to starting the pump, carefully read the instructions in Chapter 4. *Installation*.

5.1. STARTING THE PUMP



Carefully read Chapter 8. *Technical Specifications*. INOXPA cannot be held responsible for the improper use of the equipment.



NEVER touch the pump or the pipes if hot liquids are being pumped.

5.1.1. Checks before starting up the pump

- Fully open the shut-off valves on the suction and discharge pipes.

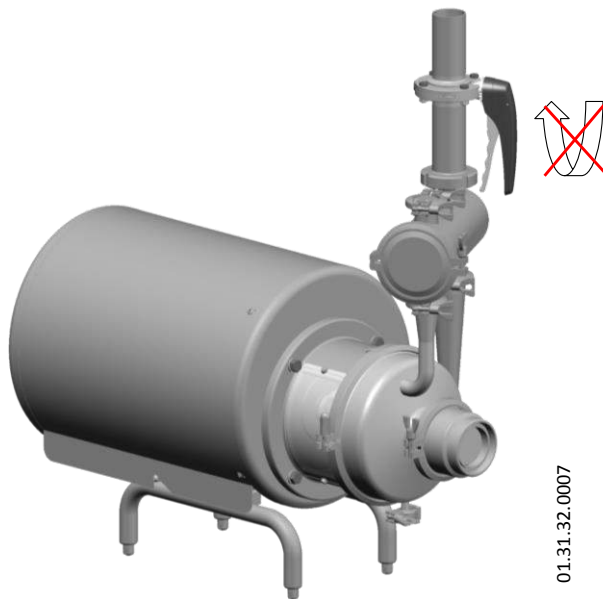

ATTENTION! EXPLOSION HAZARD!
Never start the pump if the discharge valve is closed.

- The PROLAC HCP SP pump must be filled with liquid prior to start-up. This can be done through the fill hole located at the top of the separator tank.

Pump type	Priming volume Litres
HCP SP 50-150	3.5
HCP SP 50-190	3.8
HCP SP 65-215	7



The pump must NEVER rotate without a liquid inside it.



The pump must not be allowed to operate too long without pumping (10 minutes), as it heats up and the priming liquid is lost due to evaporation.

- Check that the direction of rotation of the motor is correct.

5.1.2. Checks when starting up the pump

- Check that the pump is not making any strange noises.
- Check if the absolute inlet pressure is sufficient to prevent cavitation in the pump. Check the curve to determine the minimum pressure required above the vapour pressure (NPSHr).
- Control the discharge pressure.
- Check that there are no leaks through the sealed areas.



Do not use a shut-off valve to regulate the flow in the suction pipe. All shut-off valves must be fully open during operation.



Control the motor consumption to prevent an electrical overload.

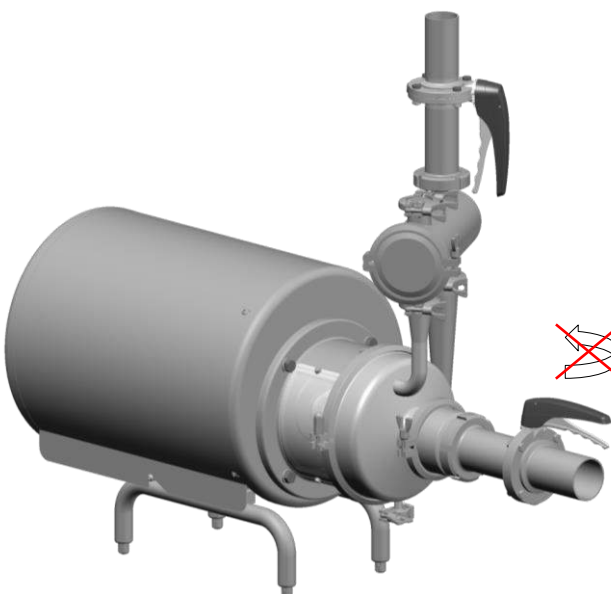

Reduce the flow rate and the electrical power consumed by the motor:

- by regulating the pump's discharge flow.
- by decreasing the motor speed.

01.31.32.0008

6. Operating problems

The following table provides solutions to problems that may arise while operating the pump. It is assumed that the pump has been properly installed and that it has been selected correctly for the specific application.

Please contact INOXPA if technical assistance is required.

Motor overload.																																			
↓	The pump flow or pressure is insufficient.																																		
↓	There is no pressure on the discharge side.																																		
↓	Uneven discharge flow rate / pressure.																																		
↓	The pump does not suck.																																		
↓	Noise and vibrations.																																		
↓	The pump gets clogged.																																		
↓	Pump overheated.																																		
↓	Abnormal wear.																																		
↓	The mechanical seal leaks.																																		
↓																																			
	<table border="1"> <thead> <tr> <th>PROBABLE CAUSES</th> <th>SOLUTIONS</th> </tr> </thead> <tbody> <tr> <td>Wrong direction of rotation</td> <td>Reverse the direction of rotation</td> </tr> <tr> <td>Insufficient NPSH</td> <td>Raise the suction tank. Lower the pump. Reduce the vapour pressure. Widen the diameter of the suction pipe. Shorten and simplify the suction pipe.</td> </tr> <tr> <td>Pump not purged</td> <td>Purge and fill the separator tank.</td> </tr> <tr> <td>Cavitation</td> <td>Increase the suction pressure.</td> </tr> <tr> <td>The pump sucks in air</td> <td>Check the suction pipe and all of its connections</td> </tr> <tr> <td>Suction pipe obstructed</td> <td>Check the suction pipe and the filters, if available</td> </tr> <tr> <td>Discharge pressure too high</td> <td>Fully open the valves in the discharge pipe. If necessary, reduce the pressure losses, for example, by increasing the pipe diameter.</td> </tr> <tr> <td>Flow rate too high</td> <td>Reduce the flow by means of a diaphragm. Partially close the discharge valve. Trim the impeller. Decrease speed</td> </tr> <tr> <td>Viscosity of the liquid too high</td> <td>Reduce the viscosity, for example, by heating the liquid</td> </tr> <tr> <td>Liquid temperature is too high</td> <td>Decrease the temperature by cooling the liquid</td> </tr> <tr> <td>Mechanical seal worn or damaged</td> <td>Replace the seal</td> </tr> <tr> <td>Inadequate O-rings for the liquid</td> <td>Install the correct O-rings after consulting the supplier</td> </tr> <tr> <td>The impeller scrapes</td> <td>Lower the temperature Reduce the suction pressure. Adjust the impeller/cover play.</td> </tr> <tr> <td>Tension in the pipes.</td> <td>Connect the pipes to the pump without tension</td> </tr> <tr> <td>Foreign matter in the liquid</td> <td>Install a filter in the suction pipe</td> </tr> <tr> <td>Mechanical seal spring tension is too low</td> <td>Adjust as indicated in this manual</td> </tr> </tbody> </table>	PROBABLE CAUSES	SOLUTIONS	Wrong direction of rotation	Reverse the direction of rotation	Insufficient NPSH	Raise the suction tank. Lower the pump. Reduce the vapour pressure. Widen the diameter of the suction pipe. Shorten and simplify the suction pipe.	Pump not purged	Purge and fill the separator tank.	Cavitation	Increase the suction pressure.	The pump sucks in air	Check the suction pipe and all of its connections	Suction pipe obstructed	Check the suction pipe and the filters, if available	Discharge pressure too high	Fully open the valves in the discharge pipe. If necessary, reduce the pressure losses, for example, by increasing the pipe diameter.	Flow rate too high	Reduce the flow by means of a diaphragm. Partially close the discharge valve. Trim the impeller. Decrease speed	Viscosity of the liquid too high	Reduce the viscosity, for example, by heating the liquid	Liquid temperature is too high	Decrease the temperature by cooling the liquid	Mechanical seal worn or damaged	Replace the seal	Inadequate O-rings for the liquid	Install the correct O-rings after consulting the supplier	The impeller scrapes	Lower the temperature Reduce the suction pressure. Adjust the impeller/cover play.	Tension in the pipes.	Connect the pipes to the pump without tension	Foreign matter in the liquid	Install a filter in the suction pipe	Mechanical seal spring tension is too low	Adjust as indicated in this manual
PROBABLE CAUSES	SOLUTIONS																																		
Wrong direction of rotation	Reverse the direction of rotation																																		
Insufficient NPSH	Raise the suction tank. Lower the pump. Reduce the vapour pressure. Widen the diameter of the suction pipe. Shorten and simplify the suction pipe.																																		
Pump not purged	Purge and fill the separator tank.																																		
Cavitation	Increase the suction pressure.																																		
The pump sucks in air	Check the suction pipe and all of its connections																																		
Suction pipe obstructed	Check the suction pipe and the filters, if available																																		
Discharge pressure too high	Fully open the valves in the discharge pipe. If necessary, reduce the pressure losses, for example, by increasing the pipe diameter.																																		
Flow rate too high	Reduce the flow by means of a diaphragm. Partially close the discharge valve. Trim the impeller. Decrease speed																																		
Viscosity of the liquid too high	Reduce the viscosity, for example, by heating the liquid																																		
Liquid temperature is too high	Decrease the temperature by cooling the liquid																																		
Mechanical seal worn or damaged	Replace the seal																																		
Inadequate O-rings for the liquid	Install the correct O-rings after consulting the supplier																																		
The impeller scrapes	Lower the temperature Reduce the suction pressure. Adjust the impeller/cover play.																																		
Tension in the pipes.	Connect the pipes to the pump without tension																																		
Foreign matter in the liquid	Install a filter in the suction pipe																																		
Mechanical seal spring tension is too low	Adjust as indicated in this manual																																		

7. Maintenance

7.1. GENERAL CONSIDERATIONS

This pump, just like any other machine, requires maintenance. The instructions in this manual cover the identification and replacement of spare parts. The instructions are aimed at maintenance personnel and those responsible for the supply of spare parts.



Carefully read Chapter 8. *Technical Specifications*.

All replaced material should be duly disposed of/recycled according to the directives in force in each area.



ALWAYS disconnect the pump before beginning any maintenance work.

7.1.1. Check the mechanical seal

Periodically check that there are no leaks around the shaft. If leakage is detected through the mechanical seal, replace it following the instructions in the section Assembly and Disassembly.

7.2. STORAGE

Before storing the pump it should be completely drained. Prevent as far as possible exposing the parts to excessively humid environments.

7.3. CLEANING



The use of aggressive cleaning products such as caustic soda and nitric acid may burn the skin.

Wear rubber gloves during all cleaning procedures.



Always wear protective goggles.

7.3.1. CIP (Clean-in-Place) cleaning

If the pump is installed in a system with a CIP process, its removal will not be required.

If an automatic cleaning process is not available, disassemble the pump as indicated in the section *Disassembly and Assembly*.

Cleaning solutions for CIP processes.

Only use clear water (chlorine-free) to mix with the cleaning agents:

a) Alkaline solution: 1% by weight of caustic soda (NaOH) at 70°C (150°F)

1 kg NaOH + 100 litres of water = cleaning solution

or

2.2 litres of 33% NaOH + 100 litres of water = cleaning solution

b) Acid solution: 0.5% by weight of nitric acid (HNO₃) at 70°C (150°F)

0.7 litres of 53% HNO₃ + 100 litres of water = cleaning solution



Check the concentration of the cleaning solutions; incorrect concentrations may lead to deterioration of the pump seals.

To remove any traces of cleaning products, ALWAYS perform a final rinse with clean water at the end of the cleaning process.

7.3.2. SIP (Sterilization-in-Place) cleaning

Sterilization with steam is applied to all equipment including the pump.



Do NOT use the equipment during the steam sterilization process.

The parts/materials will not be damaged if the indications specified in this manual are observed.

Make sure that no cold liquid enters the system until the temperature of the pump is lower than 60°C (140°F).

The pump generates an important pressure loss through the sterilization process. We recommend the use of a branch circuit with a discharge valve to ensure that steam / superheated water sterilizes the integrity of the circuit.

Maximum conditions during the SIP process with steam or overheated water

- a) **Max. temperature:** 140°C / 284°F
- b) **Max. time:** 30 min
- c) **Cooling:** Sterile air or inert gas
- d) **Materials:** EPDM
FPM

7.4. DISASSEMBLY / ASSEMBLY OF THE PUMP

7.4.1. Self-priming unit

⇒ Disassembly

1. Remove the clamping rings (85B-92E) from the discharge cone and from the return pipe. Remove the separator tank (01A).
2. Remove the CLAMP seals (85A-92F) from the discharge cone and from the return pipe. Check their condition and replace them if damaged.
3. Remove the clamp (92) from the non-return valve on the suction port.
4. Separate the valve (01B) body and remove the gasket (92A) from the body.
5. Remove the guide bushing (17E), the spring (75), the shaft (05A) and the shaft seal (80E).
6. Separate the components guide bushing, spring and shaft.
7. Remove the O-ring (80E) from its seat on the shaft.
8. Remove the clamp (87B) from the purge, the blind plug (87) and the seal (87A).

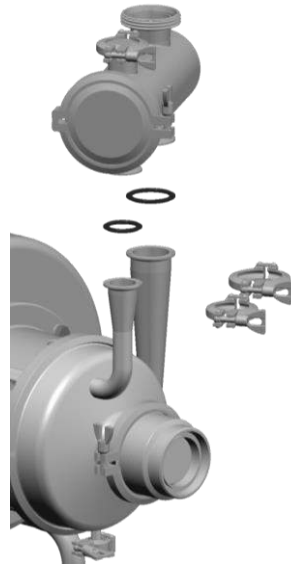

⇐ Assembly

1. Place the seal (87A) and the blind plug (87) on the purge and tighten the clamp (87B).
2. Place the seal (80E) in its seat on the shaft (05A). Grease the seal if necessary.
3. Fit the spring (75) on the shaft (05A). Take the guide bushing (17E) and attach to the shaft/spring.
4. Install the spring, shaft and bushing (75-05A-17E) assembly inside the body (01B).
5. Place the CLAMP seal (92A) in its seat on the body.
6. Place the whole assembly on the cover of the suction port of the body (01) and tighten the clamp (92).
7. Place the CLAMP seals (85A-92F) on the discharge cone and the return pipe.
8. Place the separator tank (01A) on the seals (85A-95F).
9. Fit and tighten the two clamps (85B-92E).

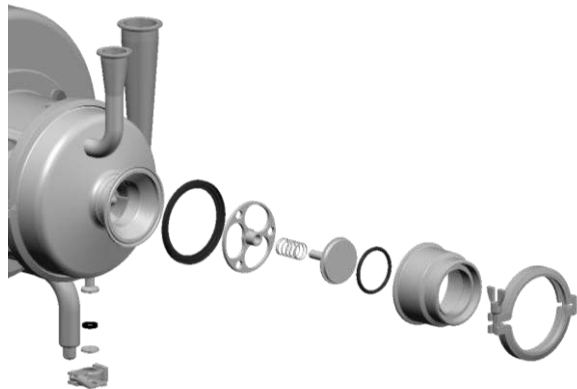

7.4.2. Pump and single mechanical seal

⇒ Disassembly

1. Remove the clamping ring (15) and disassemble the pump casing (01).
2. Check the condition of the O-ring (80) on the pump body and replace if damaged.

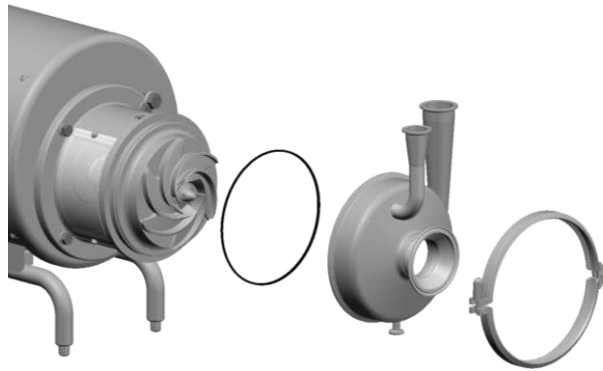

01.31.32.0011

3. Remove the screws (50) and the lantern protections (47).
4. Place an open-end wrench on the flat sides of the shaft (05) to prevent it from rotating.
5. Remove the impeller nut (45) and the O-ring (80A).
6. Pull out the impeller (02). If necessary, hit it with a dead blow using a plastic mallet in order to disengage the cone.
7. Remove the rotating part of the seal (08) from the rear side of the impeller (02).
8. Manually remove the stationary part of the seal (08) which is located in the pump cover (03).

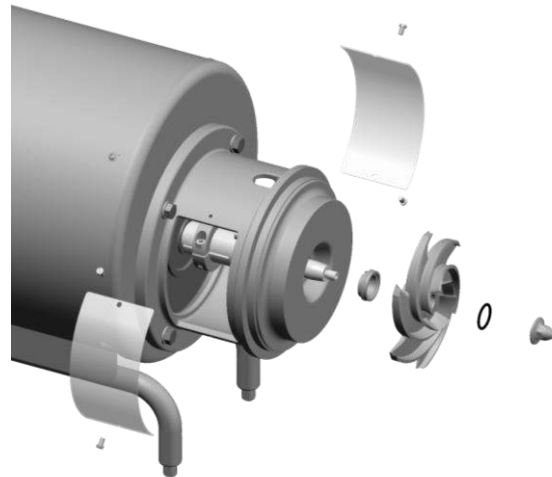

01.31.32.0012

9. If the thrust washer and the seal spring need to be replaced, loosen the Allen screws (51A) that secure the pump cover (03) and take it off. Then loosen the Allen screws (51) and remove the seal cover (09).
10. Check the spring and the thrust washer on the mechanical seal (08) and replace if necessary.

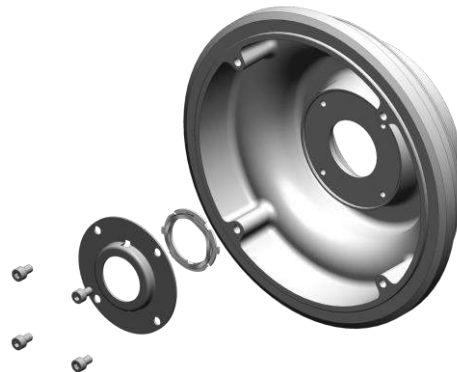

01.31.32.0013

← Assembly

1. Place the thrust washer of the mechanical seal (08) on the pump cover (03). Make sure that the four tabs centring the spring are facing outward.
2. Fit the spring on the thrust washer within the centring tabs. Place the seal cover (09) on the assembly and move it until the seal washer thrust tabs match the slots on the cover (09). Secure it with the Allen screws (51).

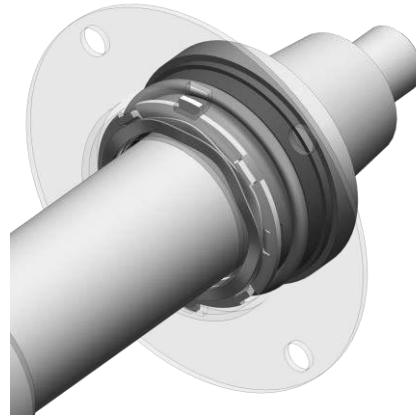

01.31.32.0014

3. Mount the pump cover (03) on the lantern (04) and secure it with the screws (51A).
4. Fit the stationary part of the seal (08) on the pump cover (03) with the fingers. Make sure that the anti-rotation tabs match the slots on the seal.
5. Fit the rotating part of the mechanical seal (08) on the rear side of the impeller (02) and make sure that it is level.
6. Place the O-ring (80A) in the slot of the impeller nut (45).
7. Place an open-end wrench on the flat sides of the shaft (05) to prevent it from rotating.
8. Insert the impeller (02) on the pump shaft (05) and secure with the nut (45).

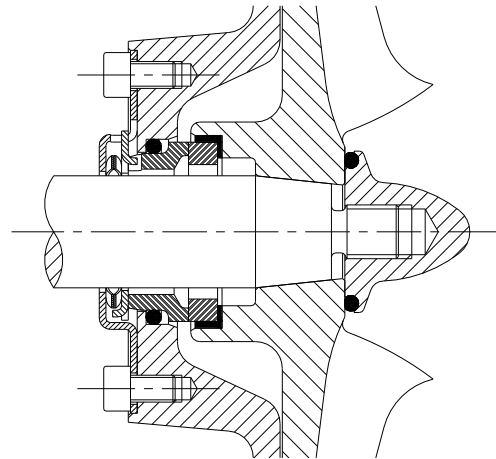

01.31.32.0015

ATTENTION! When installing the new seal, use soapy water when fitting the different parts and gaskets to allow them to slide better; apply to the stationary as well as the rotating parts.

7.4.3. Double mechanical seal

⇒ Disassembly

1. Remove the main seal following the instructions in the section [Disassembly of the single mechanical seal](#) up to point 8.
2. Loosen the Allen screws (51A) and carefully remove the pump cover (03) taking care not to damage the stationary part of the secondary seal located therein.
3. Loosen the Allen screws (51B) and remove the double seal cover (10) together with the stationary part of the secondary seal of the pump cover (03). Remove the spring and thrust washers.
4. Manually remove the stationary part of the secondary seal (08) which is located in the double seal cover (10) as well as the O-ring (80C).
5. Loosen the set screw (55) and remove the double seal ring (30) on the shaft (05) along with the rotating part of the secondary seal.
6. Remove the rotating part of the secondary seal and the O-ring (80D) from the double seal ring.

← Assembly

1. Install the rotating part of the new secondary seal and the O-ring (80) on the double seal ring (30). Slide the assembly over the pump shaft (05).
2. Fit the stationary part of the secondary seal (08) and the O-ring (80C) with your fingers on the double seal cover (10).
3. Place the thrust washer of the primary seal (08) on the pump cover (03). Make sure that the four tabs centring the spring are facing outward.
4. Fit the spring on the thrust washer within the centring tabs. Place the thrust washer of secondary seal on the spring. Make sure that the four tabs centring the spring are pointing inward.
5. Place the double seal cover (10) together with the secondary stationary part and the O-ring (80C) on the pump cover (03) and move it until the thrust tabs on the washers of the primary and secondary seals match the slots on the slots on the stationary part of the secondary seal. Secure it with the Allen screws (51B).
6. Mount the assembly of the pump cover (03) and the stationary part of the secondary seal to the lantern (04) and fasten with the screws (51A).
7. Slide the double seal ring (30) onto the shaft (05), checking that the distances between the ring and the double seal cover are as shown below, and tighten the set screw (55).

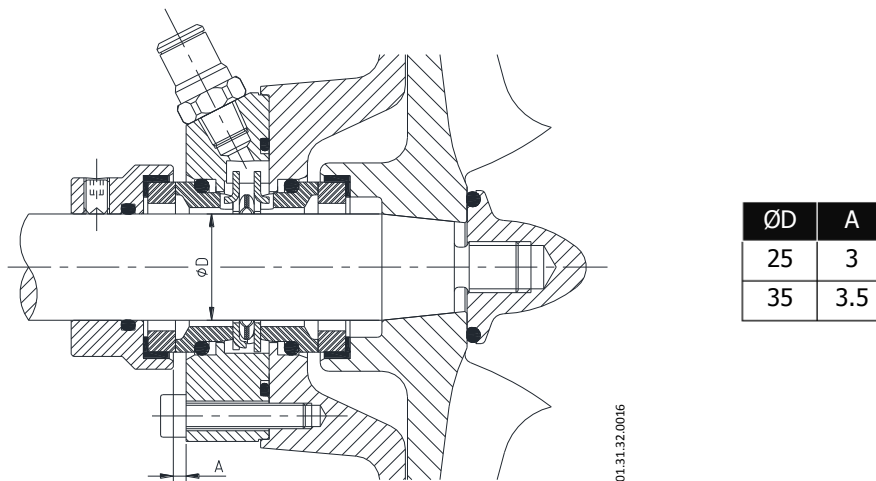

8. Install the primary seal following the assembly instructions for the single mechanical seal starting at point 4.

ATTENTION! When installing the new seal, use soapy water when fitting the different parts and gaskets to allow them to slide better; apply to the stationary parts on the cover as well as the rotating parts on the impeller and the double seal ring.

7.4.4. Installation and adjustment of the shaft

⇒ Disassembly

1. Loosen the Allen screw (51D) of the retaining ring on the shaft (17).
2. Remove the shaft (05) along with the ring (17).

← Assembly

1. Fit the pump shaft (05) together with the ring (17) on the motor shaft.
2. Tighten the Allen screw (51D) on the retaining ring only slightly and check that the pump shaft (05) can still turn. Make sure to fit the retaining ring on the shaft (17) as shown in the figure.

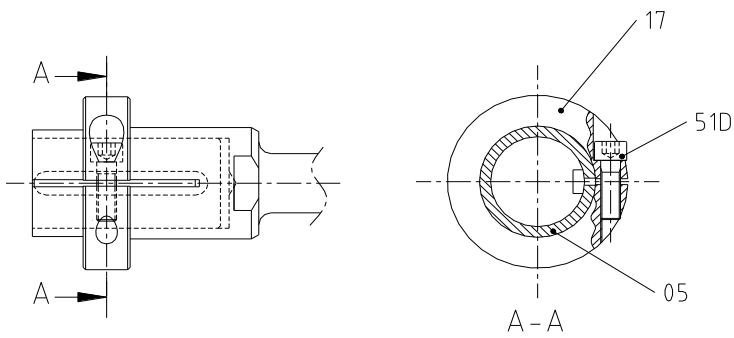

01.31.32.0017

ATTENTION! Apply assembly grease on the thread and on the head of the retaining ring screw.

3. Fit the cover (03), the screws (51A) and tighten them.
4. Install the impeller (02) on the pump shaft and secure it with the lock nut (45). Place an open-end wrench on the flat sides of the shaft to prevent it from rotating.
5. Slide the impeller with the shaft (05) until it reaches the pump cover (03).
6. Install the body (01) and secure it with the clamp (15).
7. With the help of a thickness gauge, move the pump shaft so that the impeller is located at the required distance B from the body (01): 0.4 mm for 50-150, and 0.5 mm for 50-190 and 65-215.

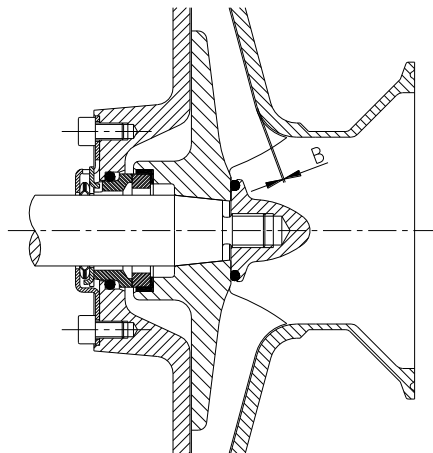

01.31.32.0018

8. Tighten the Allen screw (51D) of the retaining ring on the shaft (17).
9. Remove the body (01), the impeller (02) and the cover (03), and continue with the assembly of the mechanical seal.

8. Technical Specifications

8.1. TECHNICAL SPECIFICATIONS

Maximum operating pressure	1600 kPa (16 bar)
Temperature range	- 10 to 120 °C (EPDM)
Maximum speed	3000 rpm (50 Hz) 3600 rpm (60 Hz)
Noise level	72 to 80 dB (A) (see table for different models)

Materials

Parts in contact with the product	AISI 1.4404
Other steel parts	AISI 304 L (1.4306)
Seals in contact with the product	EPDM (standard) FPM (ask for other materials)
Other seals	NBR
Exterior surface finish	Matt
Interior surface finish	Polished Ra<0,8 µm

Mechanical seal

Type	Internal single or double seal, balanced
Material of rotating part	Silicon carbide (SiC) (standard)
Material stationary part	Graphite (C) (standard) Silicon carbide (SiC)
Seal material	EPDM (standard) FPM
Water consumption (double seal)	0.25 to 0.6 l/min
Pressure (double seal)	from atmospheric to 1000 kPa (10 bar)

Motor

Type	Three-phase asynchronous motor, IEC B35 type, 2 poles, IP55 protection, class F insulation
Power	1.5 to 18.5 kW
Voltage and frequency	220-240 V Δ / 380-420 V Y, ≤ 4 kW 380-420 V Δ / 660-690 V Y, ≥ 5.5 kW

8.2. NOISE LEVEL

The indicated noise levels correspond to the standard pump, with maximum impeller and shrouded motor, running at approx. 2900 rpm, at the point of best efficiency and with a motor with sufficient power.

These values were taken at a distance of 1 m from the pump and at a height of 1.6 m above the floor level. The measurements were carried out according to the standard EN 12639 / ISO 3746 Grade 3 with a tolerance of $\pm 3\text{dB (A)}$.

Pump type	Sound pressure LpA dB(A)	Sound power LwA dB(A)
HCP SP 50-150	74	87
HCP SP 50-190	72	85
HCP SP 65-215	80	94

It must be borne in mind that the noise levels can greatly increase if reducers, elbows or other fittings are installed near the pump.



When the sound pressure level in the operating area exceeds 80 dB(A), appropriate personal protective equipment must be used.

8.3. TIGHTENING TORQUES

If not stated otherwise, the torques listed in the following table should be applied on the nuts and bolts of this pump.

Size	Nm	lbf·ft
M6	10	7
M8	21	16
M10	42	31
M12	74	55
M16	112	83

8.4. CROSS SECTION PROLAC HCP SP

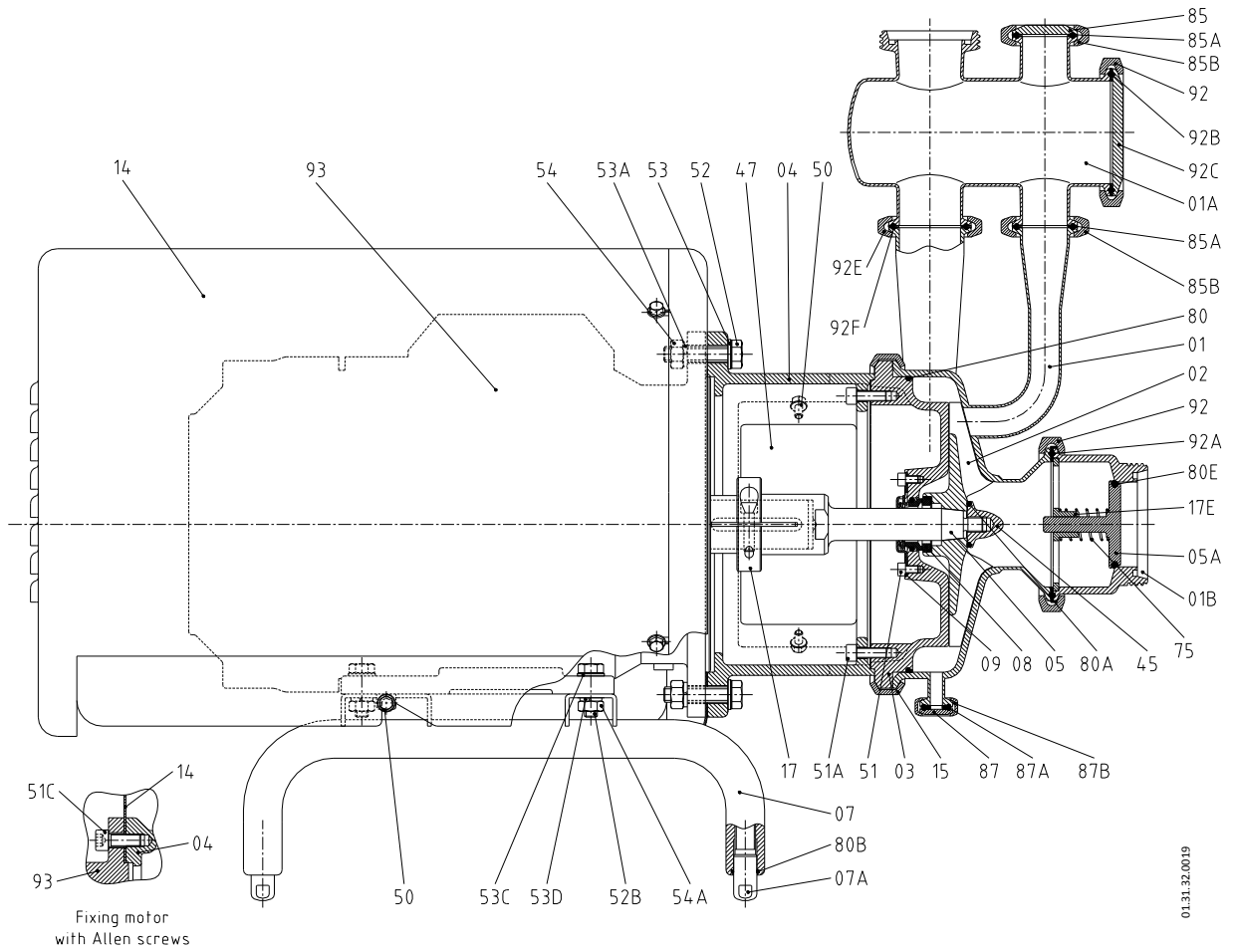

8.5. DOUBLE MECHANICAL SEAL PROLAC HCP SP

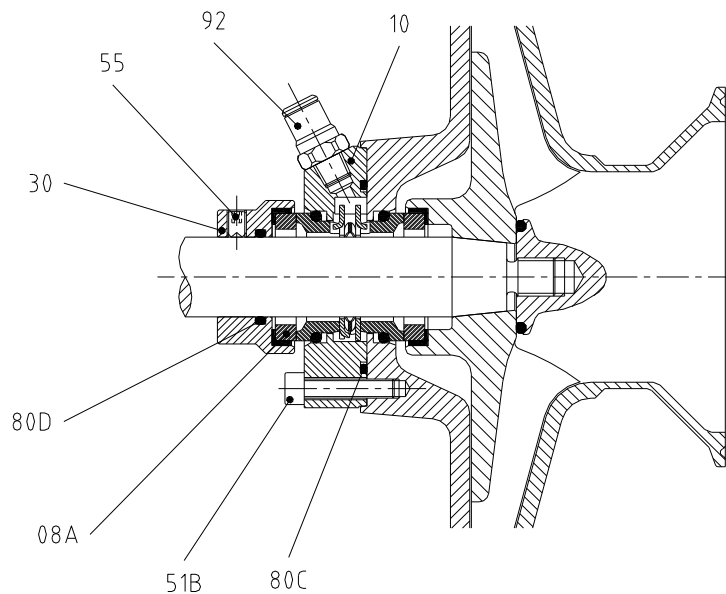

8.6. PROLAC HCP SP PARTS LIST

Item	Description	Quantity	Material
01	Body	1	AISI 316L
01A	Separator tank	1	AISI 316L
01B	Check valve body	1	AISI 316L
02	Impeller	1	AISI 316L
03	Pump cover	1	AISI 316L
04	Lantern	1	AISI 304L
05	Shaft	1	AISI 316L
05A	Check valve shaft	1	AISI 316L
07	Motor leg	2	AISI 304L
07A	Adjustable leg	4	AISI 304L
08	Mechanical seal	1	-
09	Seal cover	1	AISI 316L
14	Shroud	1	AISI 304L
15	Clamp body	1	AISI 304L
17	Motor retaining ring	1	AISI 304L
17E	Guide bushing	1	AISI 316L
45	Cap nut	1	AISI 316L
47	Lantern protection	2	PETP
50	Screw with washer	10	A2
51	Allen screw	4	A2
51A	Allen screw	4	A2
51C	Allen screw	4	A2
52	Hexagonal screw	4	A2
52B	Hexagonal screw	4	A2
53	Flat washer	4	A2
53A	Grower washer	4	A2
53C	Flat washer	4	A2
53D	Grower washer	4	A2
54	Hexagonal nut	4	A2
54A	Hexagonal nut	4	A2
75	Spring	1	AISI 302
80	O-ring	1	EPDM
80A	O-ring	1	EPDM
80B	O-ring	4	EPDM
80E	O-ring	1	EPDM
85	CLAMP ferrule	1	AISI 316L
85A	CLAMP seal	2	EPDM
85B	Clamp	2	AISI 304L
87	CLAMP ferrule	1	AISI 316L
87A	CLAMP seal	1	EPDM
87B	Clamp	1	AISI 304L
92	Clamp	2	AISI 304L

Item	Description	Quantity	Material
92A	CLAMP seal	1	EPDM
92B	CLAMP seal	1	EPDM
92C	CLAMP ferrule	1	AISI 316L
92E	Clamp	1	AISI 304L
92F	CLAMP seal	1	EPDM
93	Motor	1	-

08A	Double mechanical seal	1	-
10	Double seal cover	1	AISI 316L
30	Double seal ring	1	AISI 316L
51B	Allen screw	4	A2
55	Stud	1	A2
80C	O-ring	1	EPDM
80D	O-ring	1	EPDM
92	Straight connector 1/8" BSPT D.8	2	AISI 316

Пищевые насосы — Центробежный насос Prolac HCP SP

<http://k-tep.com.ua/>

✉ k-tep@ukr.net

■ МТС +38 066 9076563

■ Киевстар +38 098 3676414

Skype: [k-teppumps](#)

Замечания

Условия поставки: DDP склад г. Киев

Заметки

Время поставки рассчитано согласно дате предложения и изменяется в зависимости от даты подтверждения заказа.

Размещая заказ, покупатель принимает предложение и все спецификации, характеристики и условия, указанные в данном документе.