

Установка, техническое обслуживание и эксплуатация
Инструкция

Перистальтические насосы PVD70 PVDT70 PVD80 PVDT80

INSTALLATION, SERVICE AND MAINTENANCE INSTRUCTIONS

PERISTALTIC PUMP PVD 70 PVDT 70 PVD 80 PVDT 80



c/Telers, 54 Aptdo. 174
E-17820 Banyoles
Girona (Spain)

ISO 9001
BUREAU VERITAS
Certification



Original Manual
01.700.30.00702802EN_RevD
ED. 2011/02



EC DECLARATION OF CONFORMITY

(In accordance with Directive 2006/42/EC, annex II, part A)

We, the manufacturer:

c/ Telers, 54
17820 Banyoles (Girona) - Spain

Hereby declare that the products

| | |
|-------------------------|-------------------|
| <u>PERISTALTIC PUMP</u> | <u>PVD / PVDT</u> |
| Name | Type |

are in conformity with the provisions of the Council Directives:

Machine Directive 2006/42/EC, and comply with the essential requirements of said Directive and the harmonised standards:

UNE-EN ISO 12100-1/2:2004
UNE-EN 809/A1/AC:2001
UNE-EN ISO 13857:2008
UNE-EN 953:1997
UNE-EN ISO 13732-1:2007

Low-Voltage Directive 2006/95/CE (replacing Directive 73/23/CE), and conform to UNE-EN 60204-1:2006 and UNE-EN 60034-1:2004.

Electromagnetic Compatibility Directive 2004/108/CE (replacing Directive 89/336/CE), and conform to UNE-EN 60034-1:2004.

In conformity with **Regulation (CE) No. 1935/2004** on materials and objects intended to come into contact with foodstuffs (repealing 89/109/EEC), in accordance with which the materials in contact with the product do not transfer its constituents to the foodstuffs in quantities large enough to put human health at risk.

Banyoles, 2015

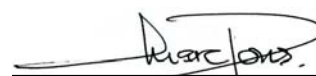
Marc Pons Bague Technical Manager

1 Safety

1.1 INSTRUCTIONS MANUAL

This manual contains information about the receipt, installation, operation, assembly, disassembly and maintenance of the PVD-70, PVDT-70, PVD-80 and PVDT-80 pumps.

The information published in the instruction manual is based on updated information.

INOXPA reserves the right to modify this instruction manual without prior notice.

1.2 START-UP INSTRUCTIONS

This Instructions Manual contains essential and useful information for properly operating and maintaining your pump.

Read these instructions carefully before starting up the pump; become familiar with the operation and use of your pump and follow the instructions closely. These instructions should be kept in a safe location near the installation.

1.3 SAFETY

1.3.1 Warning symbols



Danger for persons in general



Danger of injury caused by rotating equipment parts.



Electrical danger



Danger! Caustic or corrosive agents.



Danger! Suspended loads



Danger to the correct operation of the equipment.



Commitment to safety at the workplace.



Protective goggles requirement.

1.4 GENERAL SAFETY INSTRUCTIONS



Read this Instructions Manual carefully before installing the pump and starting it up. Contact INOXPA in case of doubt.

1.4.1 During installation



The *Technical Specifications* of Chapter 7 should always be observed.

Never start up the pump before it has been connected to the piping.

Do not start up the pump if the casing and belt protections have not been mounted.

Check that the motor specifications meet the requirements, especially when working under conditions that involve the risk of explosion.



During the installation, all the electric work should be carried out by authorized personnel.

1.4.2 During operation



The *Technical Specifications* of Chapter 7 should always be observed. Under no circumstances can the limit values specified be exceeded.

NEVER touch the pump or the pipes during operation when the pump is being used to decant hot fluids or when it is being cleaned.



The pump contains moving parts. Never place your fingers inside the pump while the pump is in operation.



NEVER operate with the suction and delivery valves closed.

NEVER spray the electrical motor directly with water. The standard protection for the motor is IP-55: Protection against dust and sprayed water.

1.4.3 During maintenance



The *Technical Specifications* of Chapter 7 should always be observed.

NEVER dismantle the pump before the pipes have been emptied. Note that the pumped fluid may be dangerous or very hot. Consult the regulations in effect in each country for these cases.

Do not leave parts loose on the floor.



ALWAYS disconnect the pump from the power supply before starting maintenance work. Remove the fuses and disconnect the cables from the motor terminals.

All electrical work should be carried out by authorized personnel.

1.4.4 Compliance with the instructions

Any non-fulfillment of the instructions may result in a risk for the operators, the environment and the machine, and may result in the loss of your right to claim damages.

This non-fulfillment may result in the following risks:

- Failure of important functions of the machines/plant.
- Failure of specific maintenance and repair procedures.
- Possibility of electric, mechanical and chemical risks.
- Will place the environment in danger due to the release of substances.

1.4.5 Guarantee

Any warranty provided shall immediately be cancelled and void *ipso jure*, and INOXPA shall be compensated for any product liability claim from third parties, if:

- the service and maintenance work was not carried out in accordance with the service instructions, or the repair work has not been carried out by our personnel or it has been conducted without our written authorization;
- our equipment has been changed without prior written authorization;
- the parts or lubricants used are not original INOXPA parts and products;
- the materials were used incorrectly or negligently, or not in accordance with these instructions and their intended use;
- pump parts were damaged by excessive pressure owing to the lack of a safety valve.

The General Delivery Terms already provided also apply.



No change can be made to the equipment without prior discussion with the manufacturer. For your safety, please use original spare parts and accessories.

The use of other parts will exempt the manufacturer from any liability.

The service terms can only be changed with prior written authorization.

Please do not hesitate to contact us in case of doubts or if more complete explanations are required on specific data (adjustments, assembly, disassembly, etc.).

2 Table of Contents

| | | |
|----------|--|----|
| 1 | Safety | |
| 1.1 | Instructions Manual | 3 |
| 1.2 | Start-up instructions | 3 |
| 1.3 | Safety | 3 |
| 1.4 | General safety instructions | 3 |
| 2 | Table of Contents | |
| 3 | General Information | |
| 3.1 | Description | 6 |
| 3.2 | Operating principle | 6 |
| 3.3 | Application | 6 |
| 4 | Installation | |
| 4.1 | Pump receipt | 7 |
| 4.2 | Transport and storage | 7 |
| 4.3 | Location | 8 |
| 4.4 | Pipes | 8 |
| 4.5 | Shut-off valves | 8 |
| 4.6 | Electrical installation | 8 |
| 5 | Start-up | |
| 5.1 | Start-up | 9 |
| 6 | Operating Problems | |
| 7 | Maintenance | |
| 7.1 | General information | 11 |
| 7.2 | Cleaning | 11 |
| 7.3 | Storage | 12 |
| 7.4 | Disassembly / Assembly of the pump | 12 |
| 8 | Technical Specifications | |
| 8.1 | Technical Specifications | 17 |
| 8.2 | Weights | 17 |
| 8.3 | PVD-70 and PVD-80 pump with dampening tanks dimensions. | 18 |
| 8.4 | PVDT-70 and PVDT-80 pump with hopper dimensions. | 18 |
| 8.5 | PVD-70 and PVD-80 pump exploded view | 19 |
| 8.6 | PVD-70 and PVD-80 pump parts list | 21 |
| 8.7 | PVDT-70 and PVDT-80 hopper dimensions | 23 |
| 8.8 | PVDT-70 and PVDT-80 hopper parts list | 24 |

3 General Information

3.1 DESCRIPTION

The peristaltic pump is part of the range of positive displacement volumetric pumps. Its operating principle is based on pressure from rollers which repeatedly squeeze the hose. The oscillation between compression and decompression of the hose creates a fall in the pressure and thus the continuous suction of the fluid, converting it into a self-suction pump. The impulse is turned into a continuous flow, whose rate is directly proportionate to the oscillation speed. The fluid inside the hose is pumped in its integral state, without suffering the slightest damage.

Its main features are:

- Self-suction up to 8m.
- Can be dry run.
- Totally sealed, without mechanical seals or gaskets.
- Excellent dosing accuracy $\pm 1\%$.
- Flow rate independent from pressure.
- Reversible pumping direction
- Easy to clean.
- Low noise.
- Easy, low-cost maintenance.
- Gentle pumping of fluids.
- Resistance to abrasion.

This equipment is suitable for use in food-processing.

3.2 OPERATING PRINCIPLE

The operation of the pump can be seen in the following figure:

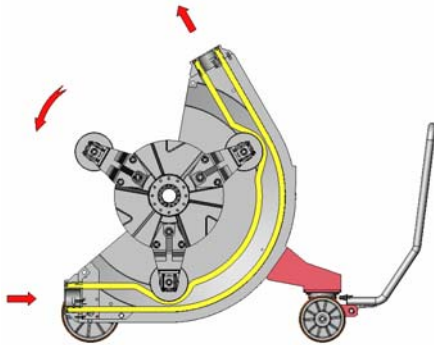

As illustrated, the pump unit has a simple, robust design, with very few moving parts.

Both ends of the flexible hose are fixed to the pump housing by means of a robust clamp. The housing contains three pressure rollers that rotate concentrically with an iron-cast disc, with at least one of them compressing the flexible hose, thus generating the pumping action.

3.3 APPLICATION

- Filtering
- Decanting.
- Bottling.
- Devatting.
- Pumping over.

3.3.1 Range of application

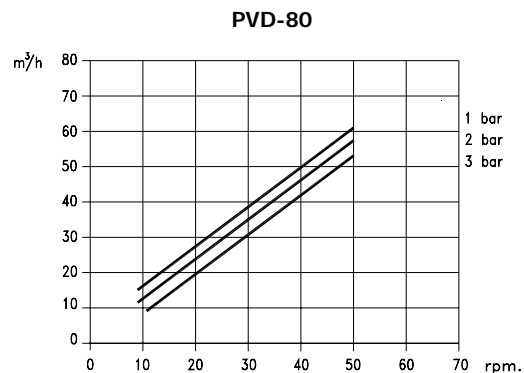
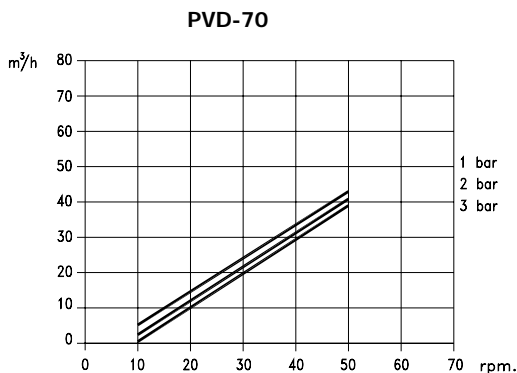

Each pump has performance limits. The pump was selected for certain pumping conditions at the time the order was placed. INOXPA shall not be liable for any damage resulting from the incompleteness of the information provided by the purchaser (nature of the fluid, rpm, etc.).

4 Installation

4.1 PUMP RECEIPT



INOXPA cannot be held responsible for the damage sustained by the equipment during transport or unpacking. Visually check that the packaging is not damaged.

The pump will be accompanied by the following documents:

- Dispatch notes.
- Pump Instructions and Service Manual.
- Motor Instructions and Service Manual (*)
- (*) when the pump is supplied with a motor by INOXPA.

Unpack the pump and check the following:

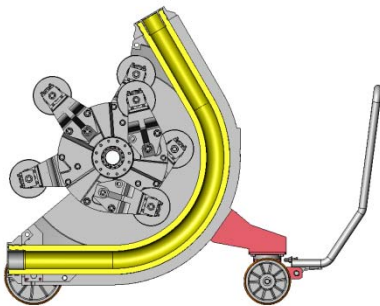

- The pump suction and delivery connections, removing the remains of any packaging materials.
- Check that the pump and the motor have not suffered any damage.
- If the equipment is not in good condition and/or any part is missing, the carrier should draw up a report accordingly as soon as possible.
- Check that the pump contains three rollers that have been rotated, two on one side of the disc and one on the other, so that none of them are pressing on the flexible hose or have damaged it during transport. Before starting up the pump, these three rollers should be assembled correctly.

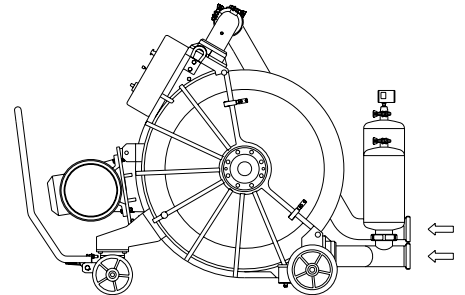

4.1.1 Pump identification

| | | |
|---|-------------------------|------------------------------|
| INOXPA S.A. C. Tellers, 54 - P.O. BOX 174 17820 BANYOLES - GIRONA (SPAIN) Tel. 972 57 52 00 - Fax 972 57 55 02 | | CE |
| TIPO <input type="text"/> | Nº <input type="text"/> | AÑO <input type="text"/> |
| KW <input type="text"/> min ⁻¹ <input type="text"/> | V <input type="text"/> | Hz <input type="text"/> |
| QM ³ /h <input type="text"/> | Hm <input type="text"/> | ØRODETE <input type="text"/> |

Serial number

Pump plate

4.2 TRANSPORT AND STORAGE



PV pumps are too heavy to be stored manually.

Lift the pump as shown below:

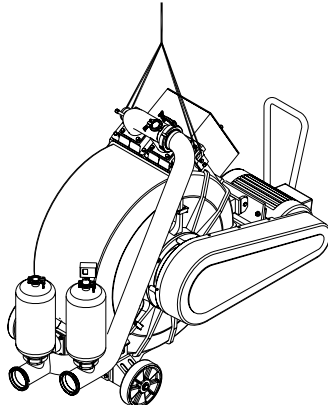

- Always use the two eyebolts to lift the pump.
- Secure the slings so that they can not slip.

4.3 LOCATION

- Place the pump as close as possible to the suction tank, and if possible below the fluid level.
- Place the pump so as to allow sufficient space around it to access the pump and the motor. (See chapter 8. *Technical specifications* for dimensions and weights).
- Place the pump on a flat, level surface.



Install the pump so as to allow sufficient ventilation. If the pump is installed outdoors, it should be protected by a roof. Its location should enable easy access for any inspection or maintenance operations.

4.4 PIPES

- As a general rule, the suction and delivery pipes should be fitted in straight sections, with the least possible number of bends and accessories in order to minimize head loss caused by friction.
- Ensure that pump input and output fittings are properly aligned with the piping and of a similar diameter to the pump connections.
- Place the pump as close as possible to the suction tank, if possible below the fluid level, or even below the tank, to achieve the maximum static suction head.
- Place pipe supports as close as possible to the pump's suction inlet and outlet.

4.5 SHUT-OFF VALVES

The pump can be isolated for maintenance purposes. To this end, shut-off valves should be fitted to the pump's suction and discharge connections.

These valves should ALWAYS be open when the pump is operating.

4.6 ELECTRICAL INSTALLATION



The connection of the electrical motors must be performed by qualified personnel. Take all necessary measures to prevent damage to connections and cables.



The electrical equipment, terminals and components of the control systems may still contain electric current when switched off. Contact with them may be dangerous for operators or cause irreversible damage to the equipment.

Before opening the pump, make sure that the electrical circuit is switched off.

Connect up the motor following the manufacturer's instructions.

Check the direction of rotation. The pump is fully reversible.

The rotation direction determines which is the suction and which is the discharge pipe on the pump. The pressostat and pressure transducer must always be placed in the discharge pipe in order to work.

The electrical switchboard diagram shall be provided on a sheet separate to this manual.

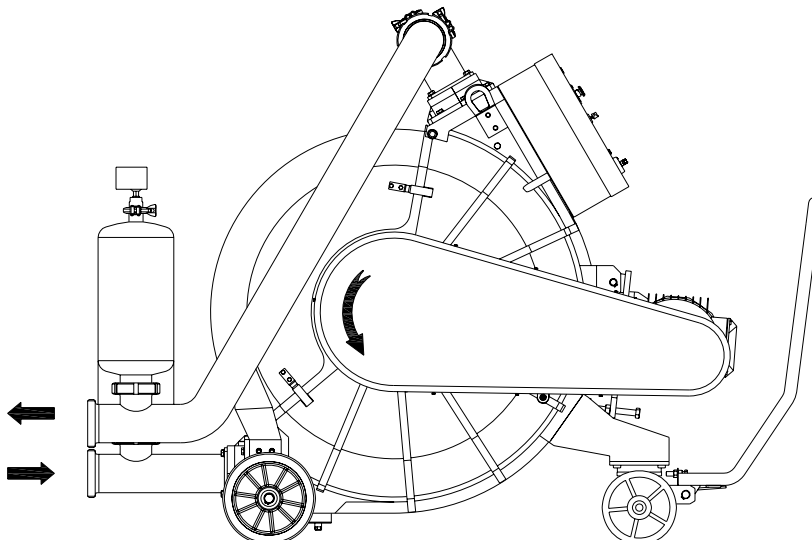

5 Start-up



Before starting the pump, carefully read the instructions provided in Chapter 4. [Installation](#).

5.1 START-UP



Read Chapter 7, [Technical Specification](#) carefully. INOXPA cannot be held responsible for the incorrect use of the equipment.



NEVER touch the pump or the pipes when hot fluid is being pumped.

5.1.1 Checks before starting up the pump

- Check that the flexible hoses and rollers are correctly mounted and greased. The grease used in the INOXPA pump is silicone based food grade grease. All the pumps are provided with a tub of grease for the pump maintenance.
- Fully open the shut-off valves on the suction and discharge pipes.
- Check that the motor direction of rotation is correct.
- Check that the optional electrical components are connected to the control panel and check that it is working.



The flexible hoses and rollers should always be greased.

Check that the rollers are mounted correctly, as the hose may be damaged if the pump is switched on when three of them are disassembled. See chapter 6, [Maintenance](#).



Do not start up the pump if the casing and belt protections have not been mounted. The pump is provided with a safety system preventing start-up if the casing protection is disassembled.

5.1.2 Checks when starting up the pump

- Check that the pump is not making any unusual noises.
- Check the flow pressure.
- Check that there are no leaks in the pump seals.
- Check that the pressure regulator is set at 3 bars.



A shut-off valve on the suction pipe must not be used to regulate flow. Shut-off valves must be fully open during operation.



Check the motor's power consumption to avoid electric overload.

6 Operating Problems

The following table provides solutions to problems that might arise during pump operation. The pump is assumed to have been properly installed and correctly selected for the application. Please contact INOXPA if technical assistance is required.

| Operating Problems | | Probable causes |
|---|---|---|
| Overheating. | | 1, 2, 3, 4, 5, 6. |
| Fall in capacity / pressure. | | 7, 8, 9, 10, 11, 12, 13, 14, 15, 16. |
| Vibrations in the pump and pipes. | | 6, 12, 17, 18. |
| Short lifetime of the hose. | | 1, 2, 3, 6, 19, 20, 21, 22. |
| Stretching of the hose inside the pump. | | 2, 23, 24, 25. |
| The pump will not start up. | | 26, 27, 28. |
| Probable causes | | Solutions |
| 1 | Use of non-original lubricant. | Use special INOXPA lubricant. |
| 2 | Insufficient amount of grease. | Grease correctly. |
| 3 | Fluid temperature too high. | Reduce the pump temperature. |
| 4 | Poor suction. | Check that there are no obstructions. |
| 5 | Hose is squeezed excessively. | Check that the shaft of the rollers is assembled in the correct position. |
| 6 | Pump speed is too high. | Reduce the pump speed. |
| 7 | Suction or discharge valve closed. | Open the valves. |
| 8 | Hose is insufficiently squeezed. | Check that the shaft of the rollers is assembled in the correct position. |
| 9 | Rupture of the hose (the product leaks into the machinery). | Change the hose. |
| 10 | Partial obstruction of the suction pipe. | Clean the pipes. |
| 11 | Lack of product in the suction tank. | Fill the tank. |
| 12 | Suction pipe section too narrow. | Increase section / reduce pump pressure. |
| 13 | Suction length too long. | Shorten the suction pipe. |
| 14 | Product viscosity is too high. | Reduce viscosity. Increase the pipe section. Check that the pump is appropriate. |
| 15 | Air is entering through the suction gaskets. | Tighten the flange seals and fittings. |
| 16 | Strong pulsations during suction. | Install a buffer tank. Re-analyze the application (speed, etc.) |
| 17 | The pipes are not anchored correctly. | Fix the pipes in place. |
| 18 | Strong pulsations in the pump. | Install delivery and/or suction pulse dampers. |
| 19 | Chemical corrosion. | Check the compatibility of the hose both with the fluid being pumped and the cleaning product. |
| 20 | Operating pressure too high. | Reduce the pump speed. Increase the pipe section. |
| 21 | Abnormally high temperature. | Check that the shaft of the rollers is assembled in the correct position. |
| 22 | Cavitation. | Re-analyze suction conditions. |
| 23 | High suction pressure (>3 bar). | Reduce suction pressure. |
| 24 | The hose is filled with sediment. | Clean the hose. |
| 25 | Clamps insufficiently tightened. | Tighten clamps. |
| 26 | Operating equipment torque insufficient. | Increase operating power. |
| 27 | Frequency converter torque insufficient. | Increase torque. Check that there is sufficient power supply. Do not operate below a frequency of 12 Hz. The motor will start up at less than 12 Hz. |
| 28 | Blocked pump. | Check that there are no blockages in the pump. |



If the problems persist, stop using the pump immediately. Contact the pump manufacturer or their representative.

7 Maintenance

7.1 GENERAL INFORMATION

Like any other machine, this pump requires maintenance. The instructions contained in this manual cover the identification and replacement of spare parts. The instructions have been prepared for maintenance personnel and for those responsible for the supply of spare parts.



Please carefully read Chapter 7 *Technical Specifications*.

All replaced material should be duly eliminated/recycled according to the directives in effect in the area.



ALWAYS disconnect the pump from the power supply before undertaking maintenance work.

7.1.1 Checking the hose.

The flexible hose must be greased regularly - approximately every 100 hours - with silicone-based food-grade grease that is already supplied with the pump.

Check the hose regularly for signs of significant wear. The hose has a durability of approximately 1000 hours provided the pump is operated under normal conditions and the hose has been correctly greased. If significant wear is noted, replace the hose in accordance with the instructions in Chapter 7, in the section on Assembly and Disassembly of the Pump.

The pump is provided with a safety system so that when a small auxiliary tank is filled up due to breakage of the hose, the pump is automatically stopped.

7.2 CLEANING



The use of aggressive cleaning products such as caustic soda and nitric acid may cause burns to the skin.

Use rubber gloves during the cleaning process.



Always use protective goggles.

7.2.1 CIP (Clean-in-place) cleaning

If the pump is installed in a system with a CIP process, it is not necessary to dismantle the pump.

If there is no automatic cleaning process, dismantle the pump as indicated in the *Assembly and Disassembly* section.

Cleaning solutions for CIP processes.

Only use clear water (chlorine-free) to mix with the cleaning agents:

a) Alkaline solution: 1% by weight of caustic soda (NaOH) at 70°C (150°F)

1 Kg NaOH + 100 l. of water = cleaning solution

2.2 l. NaOH at 33% + 100 l. of water = cleaning solution

b) Acid solution: 0.5% by weight of nitric acid (HNO₃) at 70°C (150°F)

0.7 liters HNO₃ at 53% + 100 l. of water = cleaning



Check the concentration of the cleaning solutions to avoid damaging the pump seals.

To eliminate the remains of cleaning products, ALWAYS carry out a final rinse on completion of the cleaning process.

7.2.2 Automatic SIP (sterilization-in-place)

The steam-sterilization process is applied to all equipment including the pump.



DO NOT operate the equipment during the steam-sterilization process.
The parts/materials will not suffer damage provided the instructions set out in this manual are followed.

Cold liquid cannot be introduced until the pump temperature is below 60°C (140°F).

The pump generates a substantial pressure loss during the sterilization process; we recommend the use of a bypass circuit provided with a discharge valve to ensure that the steam / superheated water sterilize the entire circuit.

Maximum conditions during the steam or superheated-water SIP process

- a) **Max. temperature:** 140°C / 284°F
- b) **Max. time:** 30 min
- c) **Cooling:** Sterilized air or inert gas
- d) **Materials:** EPDM / PTFE (recommended)
FPM / NBR (not recommended)

7.3 STORAGE

The pump must be completely emptied of fluid before storage. If possible, avoid exposing the components of the agitator to excessively damp environments.



Spare hoses should be stored in a dry place protected from direct sunlight.

If the pump is not operated for a long period of time, three rollers that have been rotated must be assembled, two on one side and one on the other, and fixed with two of the three screws using the same bores as the roller support. Then, turn the roller disc so that none of the remaining ones compresses the hoses and damages them (see below).

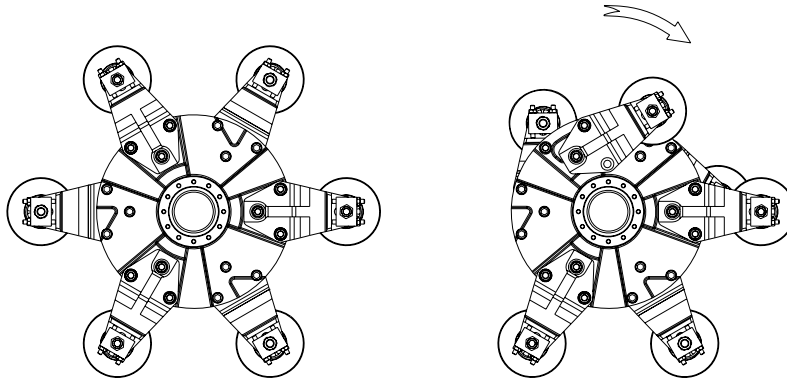

Disassemble three rollers when the pump is not used for extended periods of time so that none of the rollers press the hoses and damage them.

7.4 DISASSEMBLY / ASSEMBLY OF THE PUMP

7.4.1 Inlet/outlet pipes and buffer tanks

⇐ Disassembly

Remove the screws (52A) fastening the pump inlet, outlet, and lowering pipes (98, 98A, 98B) to the buffer tanks. Loosen the nuts from the adapter to separate the buffer tanks. Loosen the hexagonal nuts (54A) and screws (52D) in order to separate the two parts of the tank (01A) and O-ring (80A).

⇒ Assembly

First assemble the parts constituting the buffer tank. Attach the O-ring (80A) over the groove and fix both parts of the tank (01A) using the hexagonal screws (52D), washers (53A), and nuts (54A). Also place the cap (85) and/or pressure regulator on the discharge pipe. Mount the two tanks, if these are necessary for the intended use, onto the inlet, outlet, and lowering pipes (98, 98B) with the nut adapters and seal adapters (91). Place these assemblies on pump housing and fasten them with hexagonal screws (52A) and washers (53A). Screws (52E) must also be inserted at the bottom of the lowering pipe (98B).

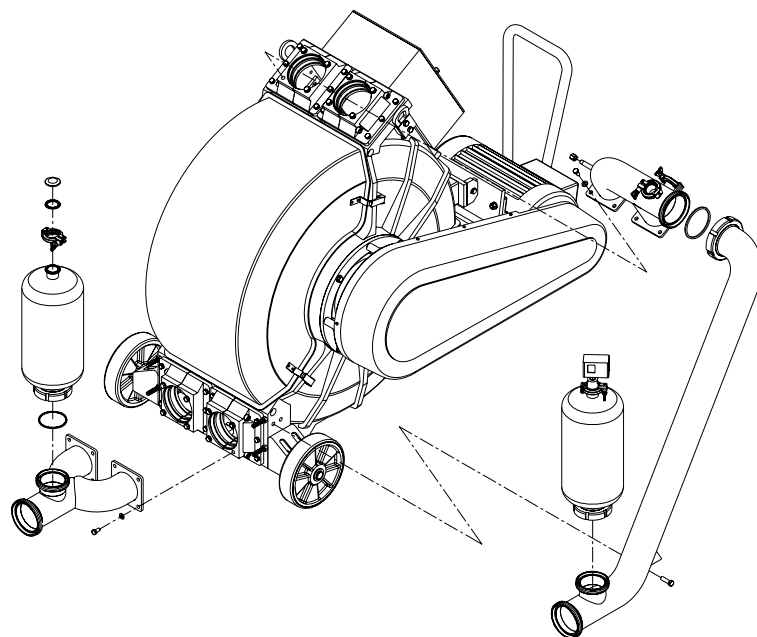

7.4.2 Changing the hose

← Disassembly

First proceed according to the disassembly instructions for the buffer tanks. First, remove the casing cover (03) by detaching the closure hooks (15) and the position sensor preventing start-up of the pump without the cover. Loosen the Allen screws (51B) and remove the screws (52C) in order to detach the hose clamp (33A) and the pipe adapter (33). Carry out the same procedure for the four connections. In order to remove the hoses (22), start up the motor in a clockwise direction with the frequency selector on the lowest setting or by unlocking the motor brake and manually turning the roller discs (06A) depending on the drive type, and remove the hoses through the bottom connection as indicated in the figure below.

⇒ Assembly

Before fitting the hoses, check that the rollers and the inside of the pump housing (01) are greased, and grease them if required. Fit the new hoses as shown in the figure below until they touch the first roller on each side of the roller disc. Start up the motor in a clockwise direction as viewed from the belt side, and as the rollers turn, they will move the hose (22) into place. When the hose is fully inside the housing, stop the motor. Place the O-ring (80) on the hose (33), and place the latter on the hose end, then fix the hose (22) to the body (01) with the hose clamp (33A) and the screws (51B, 52C). Carry out the same procedure for the four connections.

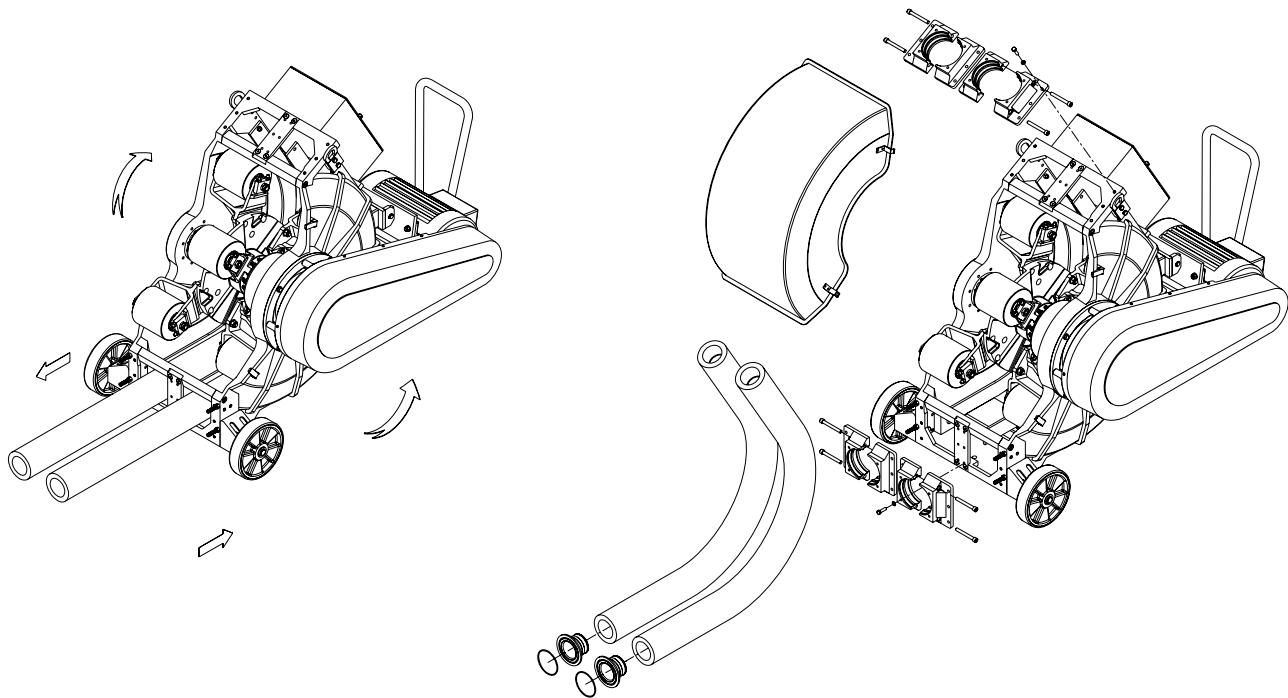

7.4.3 Changing belts and pulleys

← Disassembly

Remove the belt protection (48) by removing the screws (50). Loosen the belts (105) by loosening the screw (52M) enough for them to be removed. Remove the belts (105) and take out the pulleys (104, 104A). The pulleys consist of a conical hub with two fixing bores and one extraction bore.

⇒ Assembly

Fit the pulleys (104, 104A) onto the drive shafts and line them up. Place the five belts (105) and tighten them by inserting the hexagonal screw (52M) as tightly as needed. After a few hours of operation, check that they have not lost their tautness.



Do not tighten the belts too much as this may damage the reducer and motor bearings.

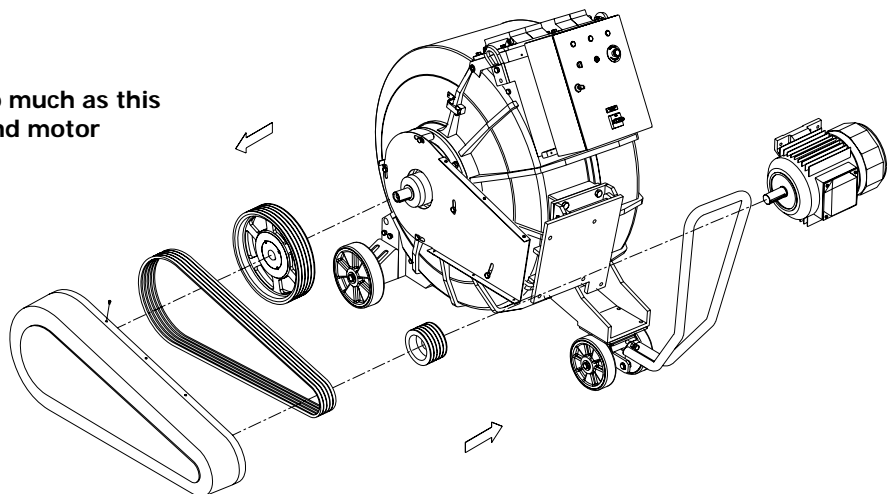

7.4.4 Reducer and roller disc

⇒ Disassembly

First disassemble according to the belts and pulleys section. Then, remove the screws (52J, 52K) so that the belt protection cover (48A) and the long (17B) and short (17A) separators come out. Remove the casing cover (03). Hold the roller disc (06A) in place with slings. Remove the roller disc (05) with its bearing (70) and the spacer support (06F) by taking out the screws (52N). Loosen the screws (52B) in order to take out the roller disc (06A) with the mounted rollers (02). Remove the screws (52G) and take out the reducer support (06) with the reducer still assembled (93). Finally, loosen the countersunk screws on the front washer of the reducer and remove the flange fixed to the reducer shaft; remove the nuts (54B) and screws (52I) in order to take out the reducer (93).

← Assembly

Assemble the reducer (93) on the reducer support (06) with the screws (52I) and nuts (54B). Place the reducer flange on the grooved reducer shaft (93) and fasten it with the washer and countersunk screws. Attach this group to the housing (01) with the screws (52G). Place the roller disc (06A) on the reducer flange alignment and fasten it with the screws (52B) while holding the disc in place. Attach the spacer support (06F) to the roller disc with the screws (52N). Assemble the bearing (70) on the roller disc shaft (05) and fasten it with an elastic ring (66). Place the roller disc shaft (05) on the spacer support (06F) and fasten it to the casing (01) with the screws (52G).

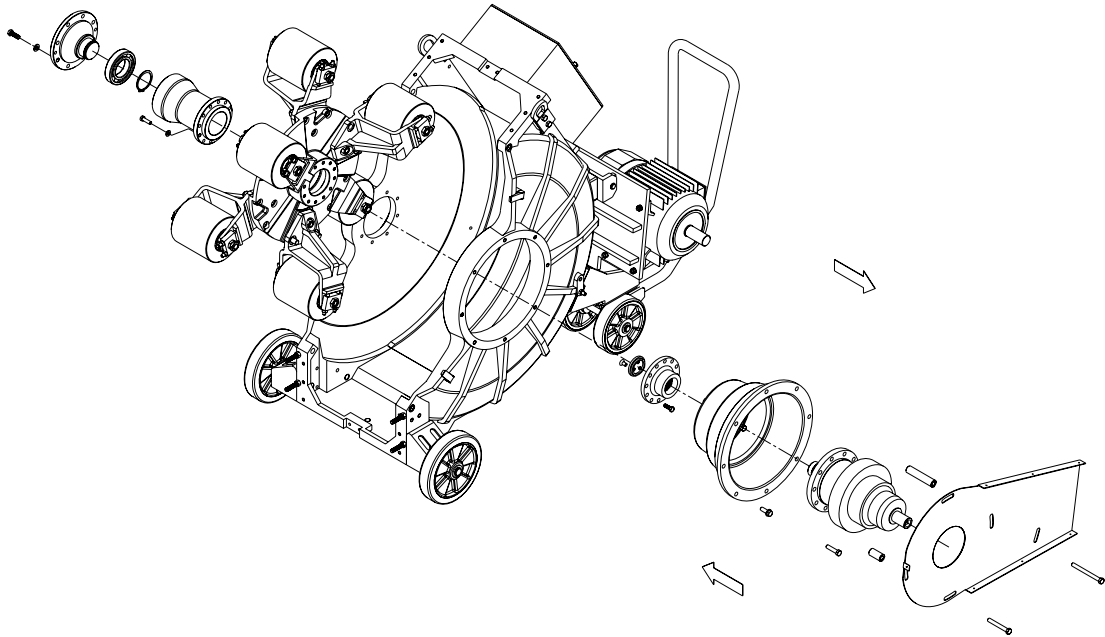

7.4.5 Rollers



Before disassembling the roller, measure distance A on the figure below and observe the same distance during assembly or using the checking gauge that goes with the pump.

← Disassembly

Remove the casing cover (03). Remove the screws (51A) and self-locking nuts (54C) of the roller. Loosen the nuts (45) so that the check plates (110), roller stop bushings (17), and the roller shaft screw (25) can come out.

⇒ Assembly

Place a nut (45) on the shaft and assemble it all on the roller support (06B) until the pins (55) of the check plate come to a stop, and fix the whole assembly using the nut (45) and secure it with another nut (45). The position of the roller is given when the checking gauge is collocated like a figure below, having the roller (02) in one side and the flange of spacer support (06F) on the other, or as cote A from before the disassembly.



If the pump will not be in use for an extended period, remove three rollers, two from one side of the disc and one from the other, so that none of the rollers presses on the hose and damages it. See section 7.3 of this chapter.

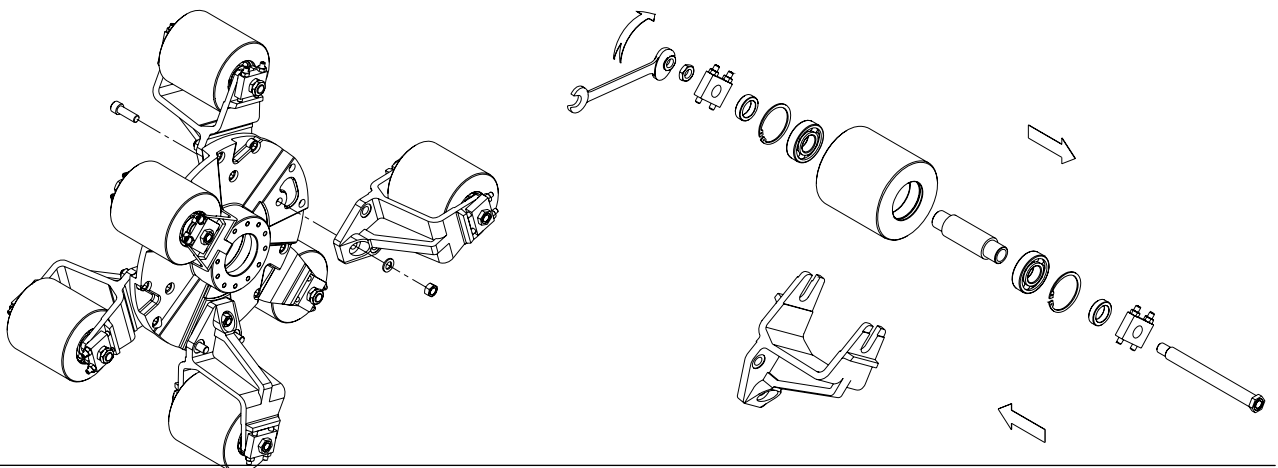

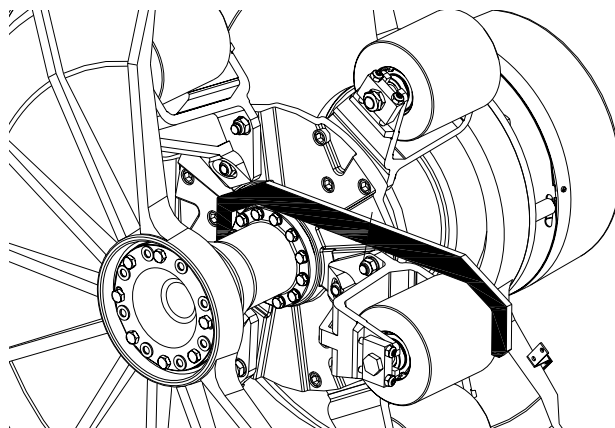
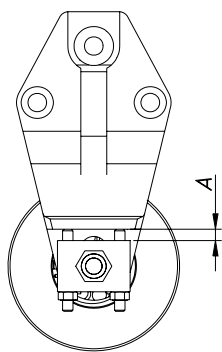

7.4.6 Hopper (optional)

The pump hopper has five gears that must be greased regularly, in order to ensure correct operation, by means of three grease nipples (83) located on the support (06) and the guide bushing support (06C).



Grease the hopper gears.



Do not remove the hopper grille in order to avoid personal injury.

8 Technical Specifications

8.1 TECHNICAL SPECIFICATIONS

| | |
|---------------------------------------|----------------------------------|
| Operating temperature range | -10°C to +80°C 14°F to +176°F |
| Noise level | 60-80 dB(A) |
| Suction / discharge connections | DIN 11851 (standard) |



Use special protection when the noise level in the operation area exceeds 85 dB(A).

Two-speed motor pump

| Pump type | Flow rate [m ³ /h] | Max. pressure [bar] | Speed [rpm] | Power [kW] |
|-----------|-------------------------------|---------------------|-------------|------------|
| PVD-70 | 20 – 40 | 3 | 25 - 50 | 9.6 / 7 |
| PVD-80 | 30 – 60 | | | 12.5 / 9 |
| PVDT-70 | 7 – 40 | 2.5 | | 9.6 / 7 |
| PVDT-80 | 10 – 60 | | | 12.5 / 9 |

Pump with integrated motor and frequency converter.

| Pump type | Flow rate [m ³ /h] | Max. pressure [bar] | Speed [rpm] | Power [kW] |
|-----------|-------------------------------|---------------------|-------------|------------|
| PVD-70 | 10 – 40 | 3 | 9 - 50 | 9.2 |
| PVD-80 | 15 – 60 | | | 11 |
| PVDT-70 | 7 – 40 | 2.5 | | 9.2 |
| PVDT-80 | 10 – 60 | | | 11 |

Materials

| | |
|---|-----------------|
| Parts in contact with the product | AISI 304 |
| Hose | NR-A (standard) |

8.2 WEIGHTS

| Pump type | Pump weight with motor | |
|-----------|------------------------|-------|
| | [kg] | [lbs] |
| PVD-70 | 700 | 1543 |
| PVD-80 | 935 | 2061 |
| PVDT-70 | 850 | 1875 |
| PVDT-80 | 1095 | 2415 |

8.3 PVD-70 AND PVD-80 PUMP WITH DAMPENING TANKS DIMENSIONS.

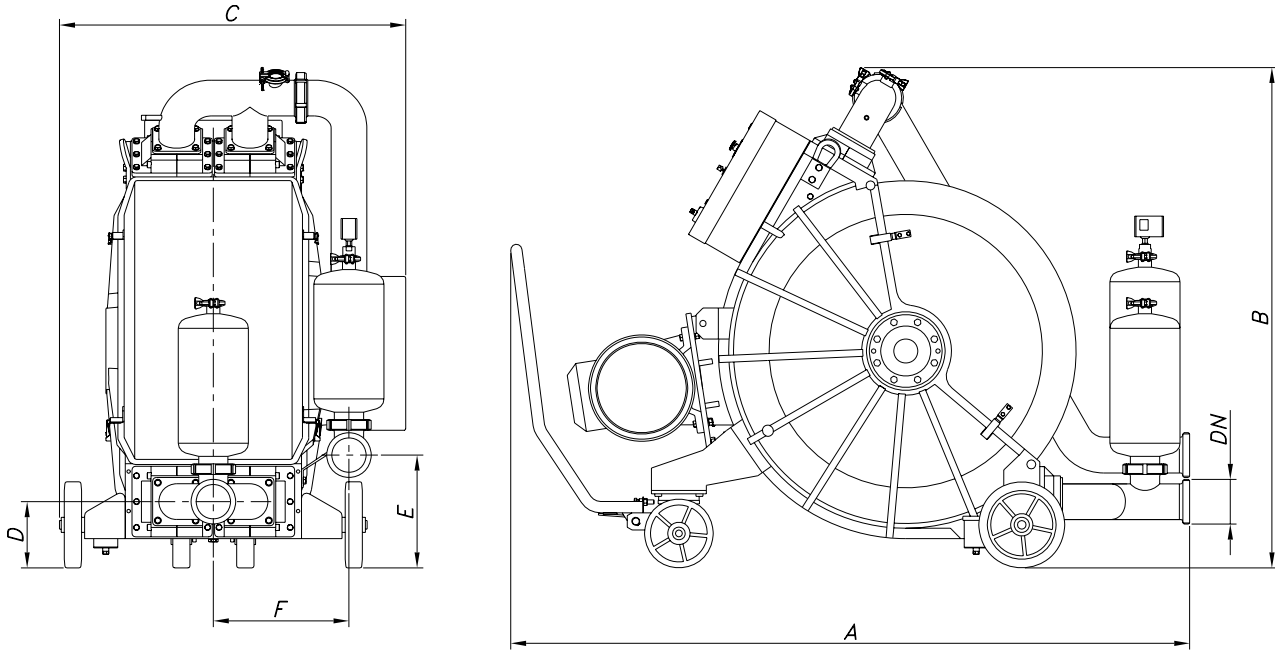

| TYPE | DN | A | B | C | D | E | F |
|---------------|-----|------|------|------|-----|-----|-----|
| <i>PVD-70</i> | 80 | 1870 | 1290 | 940 | 180 | 365 | 345 |
| <i>PVD-80</i> | 100 | 2000 | 1450 | 1020 | 195 | 325 | 395 |

8.4 PVDT-70 AND PVDT-80 PUMP WITH HOPPER DIMENSIONS.

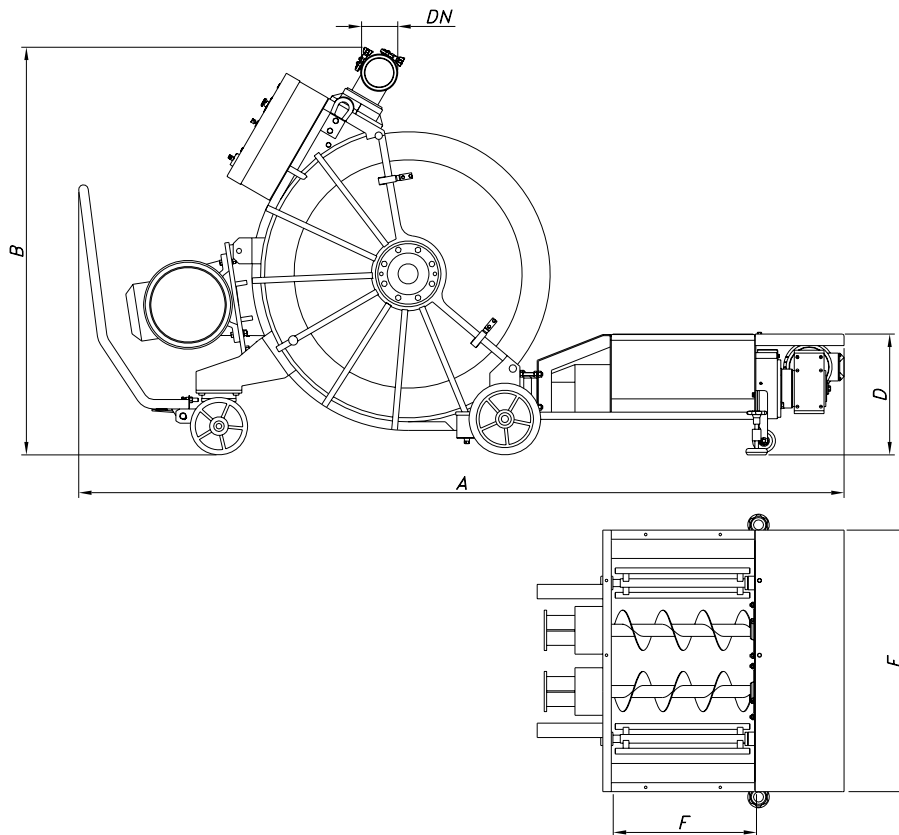

| TYPE | DN | A | B | D | E | F |
|----------------|-----|------|------|-----|-----|-----|
| <i>PVDT-70</i> | 80 | 2650 | 1290 | 405 | 910 | 500 |
| <i>PVDT-80</i> | 100 | 2700 | 1450 | 420 | | |

8.5 PVD-70 AND PVD-80 PUMP EXPLODED VIEW

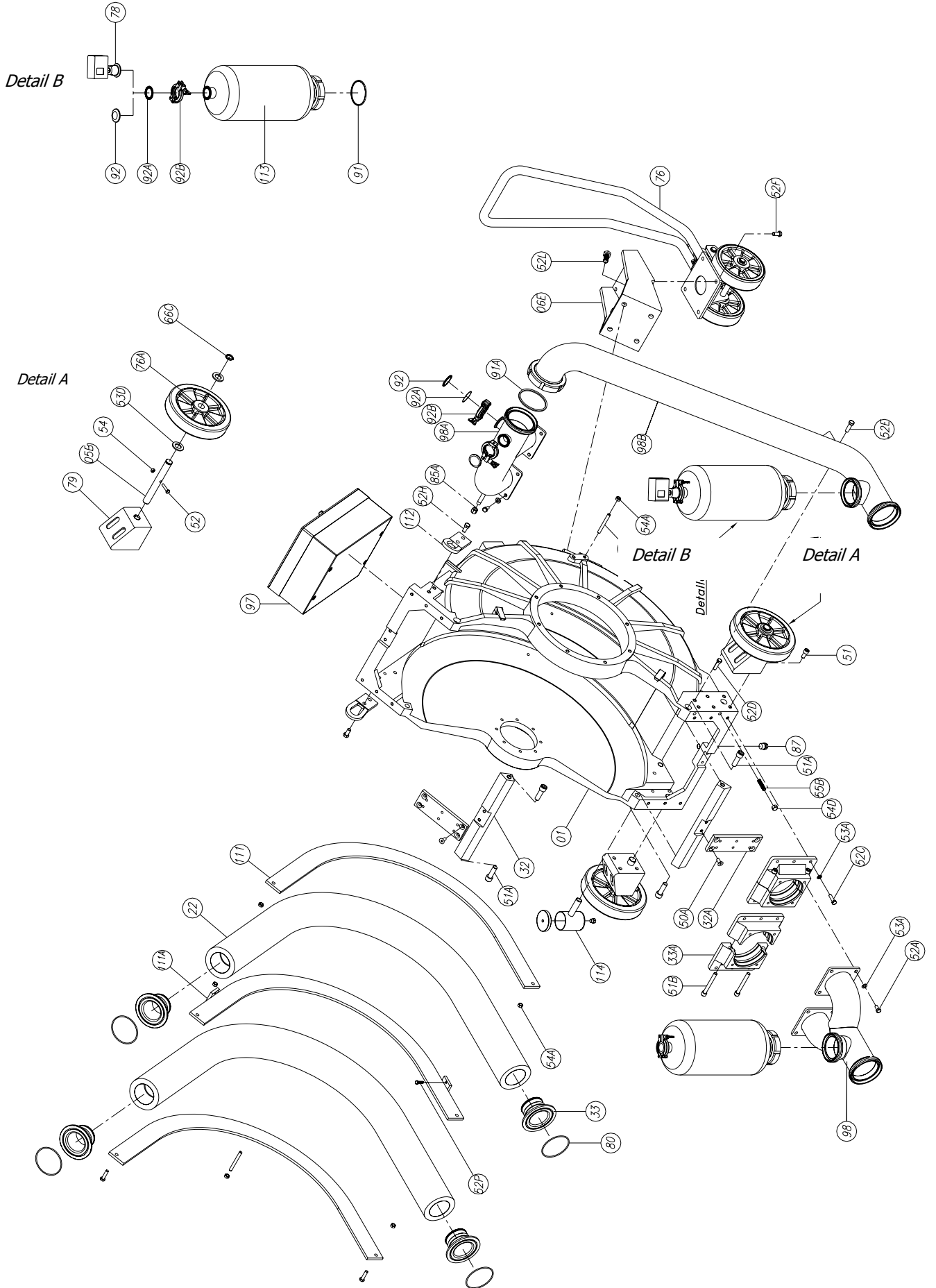

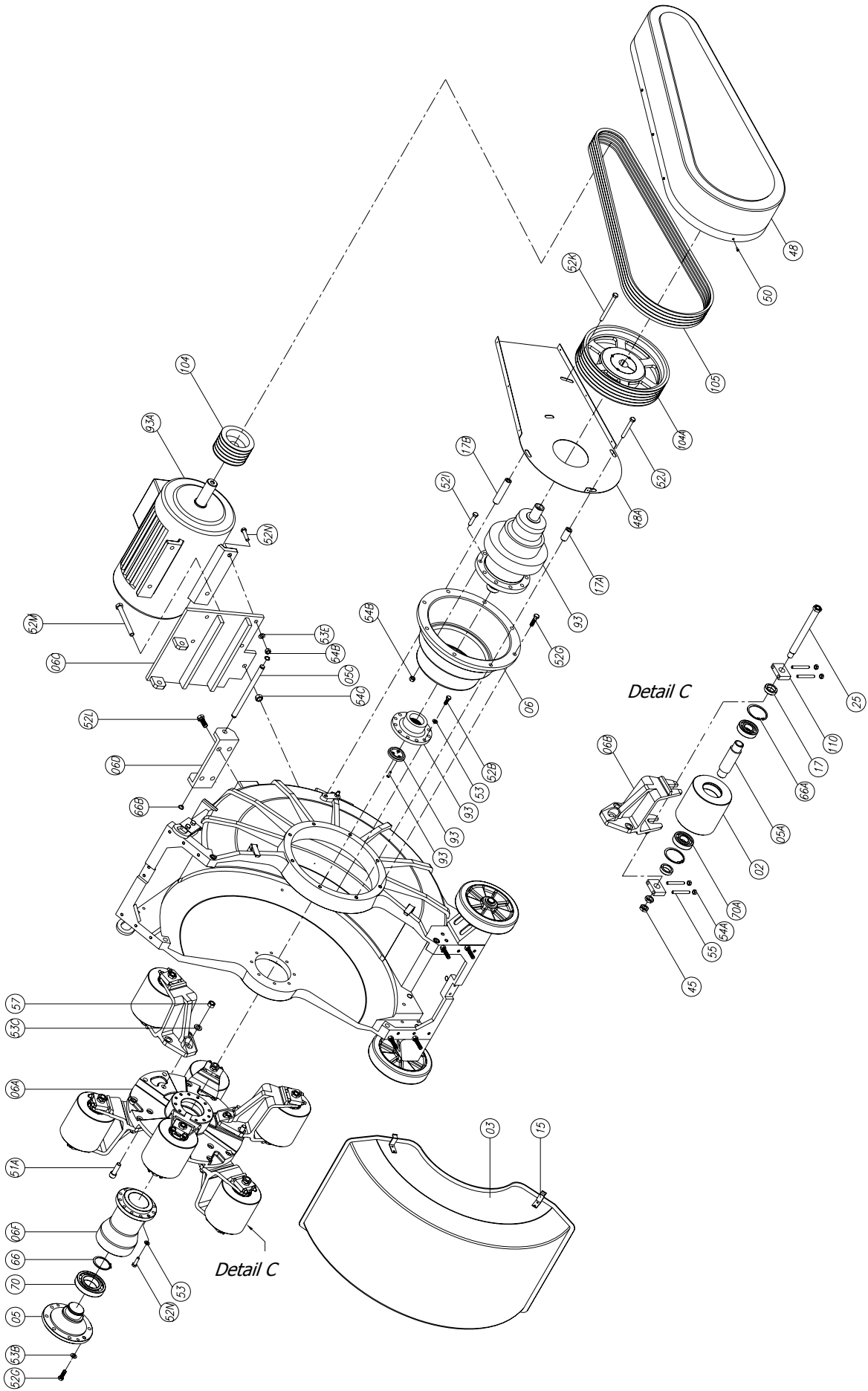

8.6 PVD-70 AND PVD-80 PUMP PARTS LIST

| Position | Description | Quantity | Material |
|----------|-----------------------------------|----------|-----------|
| 01 | Pump housing | 1 | GG-25 |
| 02 | Roller | 3 | GG-25 |
| 03 | Body cap | 1 | Polyester |
| 05 | Roller disc shaft | 1 | GG-25 |
| 05A | Roller shaft | 3 | F-114 |
| 05B | Wheel shaft | 2 | F-114 |
| 05C | Drive support shaft | 1 | F-114 |
| 06 | Reducer support | 1 | GG-25 |
| 06A | Roller disc | 1 | GG-25 |
| 06B | Roller support | 6 | GGG-42/12 |
| 06C | Drive support | 1 | F-112 |
| 06D | Drive plate support | 1 | F-112 |
| 06E | Rotary wheel support | 1 | F-112 |
| 06F | Spacer support | 1 | GG-25 |
| 15 | Closure hook cover | 4 | AISI 304 |
| 17 | Roller stop bushing | 12 | F-114 |
| 17A | Pulley-protection short separator | 4 | F-114 |
| 17B | Pulley-protection long separator | 1 | F-114 |
| 22 | Hose * | 2 | NR-A |
| 25 | Roller shaft screw | 6 | F-124 |
| 32 | Casing reinforcement | 2 | F-112 |
| 32A | Reinforcing bar | 2 | F-112 |
| 33 | Hose | 4 | AISI 304 |
| 33A | Flange | 4 | GG-25 |
| 45 | Roller fastening nut | 12 | F-124 |
| 48 | Belt protection | 1 | Polyester |
| 48A | Belt protection plate | 1 | F-112 |
| 50 | Screw | 7 | A2 |
| 50A | Countersunk screw | 8 | 8.8 |
| 51 | Allen screw | 8 | A2 |
| 51A | Allen screw | 22 | 8.8 |
| 51B | Allen screw | 8 | 8.8 |
| 52 | Hexagonal screw | 2 | A2 |
| 52A | Hexagonal screw | 8 | A2 |
| 52B | Hexagonal screw | 12 | 8.8 |
| 52C | Hexagonal screw | 12 | A2 |
| 52D | Hexagonal screw | 4 | A2 |
| 52E | Hexagonal screw | 2 | A2 |
| 52F | Hexagonal screw | 4 | 8.8 |
| 52G | Hexagonal screw | 12 | A2 |
| 52H | Hexagonal screw | 4 | A2 |
| 52I | Hexagonal screw | 14 | 8.8 |
| 52J | Hexagonal screw | 4 | 8.8 |
| 52K | Hexagonal screw | 1 | 8.8 |
| 52L | Hexagonal screw | 8 | A2 |
| 52M | Hexagonal screw | 1 | 8.8 |
| 52N | Hexagonal screw | 12 | 8.8 |

(*) Recommended spare parts

| Position | Description | Quantity | Material |
|----------|-------------|----------|----------|
|----------|-------------|----------|----------|

| | | | | |
|------|------------------------------|---|----|----------|
| 52P | Hexagonal screw | | 4 | 8.8 |
| 53 | Flat washer | | 24 | 8.8 |
| 53A | Grower washer | | 24 | A2 |
| 53B | Grower washer | | 8 | A2 |
| 53C | Flat washer | | 18 | 8.8 |
| 53D | Flat washer | | 4 | A2 |
| 53E | Grower washer | | 4 | 8.8 |
| 54 | Hexagonal nut | | 2 | A2 |
| 54A | Hexagonal nut | | 14 | A2 |
| 54B | Hexagonal nut | | 14 | A2 |
| 54C | Hexagonal nut | | 1 | 8.8 |
| 54D | Hexagonal nut | | 4 | A2 |
| 55 | Allen pin | | 24 | A2 |
| 55A | Guide stop rod | | 2 | A2 |
| 55B | Threaded rod | | 4 | A2 |
| 57 | Self-locking nut | | 18 | 8.8 |
| 66 | Elastic ring | | 1 | Steel |
| 66A | Elastic ring | | 12 | Steel |
| 66B | Elastic ring | | 2 | Steel |
| 66c | Elastic ring | | 2 | Steel |
| 70 | Oscillating roller bearing | * | 1 | Steel |
| 70A | Ball bearing | * | 12 | Steel |
| 76 | Rotary wheel and handle set | | 1 | - |
| 76A | Fixed wheel | | 2 | - |
| 78 | Membrane clamp pressostat | | 1 | - |
| 79 | Wheel support | | 2 | F-1 |
| 80 | O-ring | * | 4 | EPDM |
| 85A | Nut cap | | 1 | A2 |
| 87 | Drain plug | | 1 | A2 |
| 91 | Adapter seal | * | 2 | EPDM |
| 91A | Adapter seal | * | 1 | EPDM |
| 92 | Clamp blind bushing | | 3 | AISI 304 |
| 92A | Clamp gasket | | 4 | EPDM |
| 92B | Clamp | | 4 | AISI 304 |
| 93 | Reducer | | 1 | - |
| 93A | Motor | | 1 | - |
| 97 | Switchboard | | 1 | - |
| 98 | Inlet hose assembly | | 1 | AISI 304 |
| 98A | Outlet assembly | | 1 | AISI 304 |
| 98B | Lowering tube assembly | | 1 | AISI 304 |
| 104 | Pulley | | 1 | - |
| 104A | Pulley | | 1 | - |
| 105 | Belt | * | 5 | - |
| 110 | Roller check plate | | 6 | F-114 |
| 111 | Hose guide | | 2 | F-1 |
| 111A | Central hose guide | | 1 | F-1 |
| 112 | Eyebolt | | 2 | F-1 |
| 113 | Buffer tank | | 2 | AISI 304 |
| 114 | Hose rupture sensor assembly | | 1 | - |

(*) Recommended spare parts

8.7 PVDT-70 AND PVDT-80 HOPPER DIMENSIONS

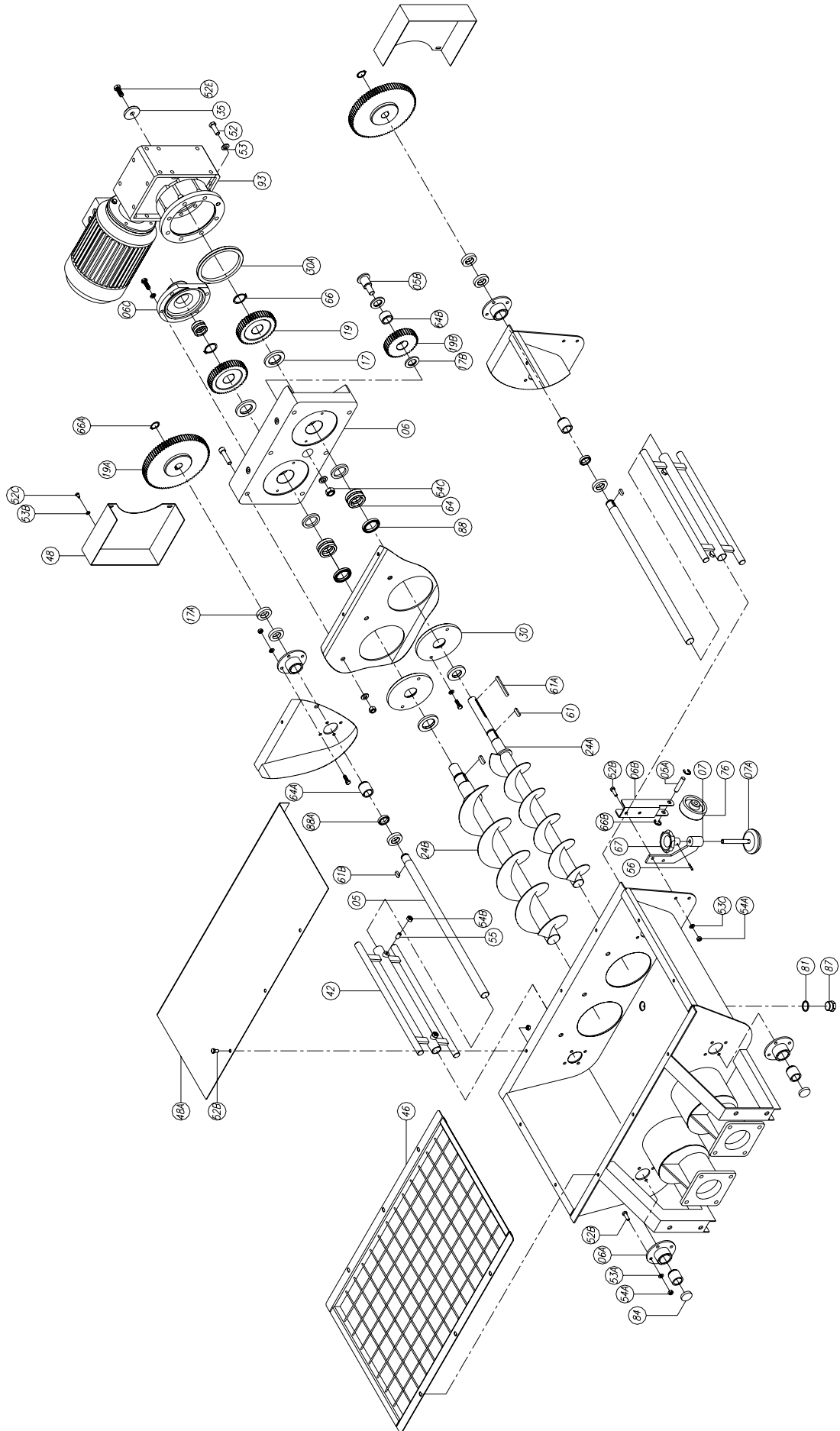

8.8 PVDT-70 AND PVDT-80 HOPPER PARTS LIST.

| Position | Description | | Quantity | Material |
|----------|------------------------------|---|----------|--------------|
| 01 | Hopper | | 1 | AISI 304 |
| 05 | Blade shaft | | 2 | AISI 304 |
| 05A | Wheel shaft | | 2 | AISI 304 |
| 05B | Intermediate pinion shaft | | 1 | F-114 |
| 06 | Support | | 1 | Aluminium |
| 06A | Guide | | 4 | AISI 304 |
| 06B | Wheel support | | 2 | AISI 304 |
| 06C | Guide bushing support | | 1 | F-114 |
| 07 | Foot support | | 2 | AISI 304 |
| 07A | Non-vibratory foot | | 2 | AISI 304 |
| 17 | Rotating washer | * | 4 | PTFE |
| 17A | Blade washer | * | 6 | PTFE |
| 17B | Pinion washer | * | 2 | PTFE |
| 19 | Reduction gear | | 2 | F-114 |
| 19A | Blade pinion | | 2 | F-114 |
| 19B | Intermediate pinion | | 1 | F-114 |
| 24A | Drive connecting rod | | 1 | AISI 304 |
| 24B | Driven connecting rod | | 1 | AISI 304 |
| 30 | Support guide plate | | 2 | AISI 304 |
| 30A | Reducer guide ring | | 1 | F-114 |
| 35 | Shaft stop washer | | 1 | AISI 304 |
| 42 | Blade | | 2 | AISI 304 |
| 46 | Grille | | 1 | AISI 304 |
| 48 | Shield | | 2 | AISI 304 |
| 48A | Drive protection | | 1 | AISI 304 |
| 51 | Allen screw | | 6 | A2 |
| 52 | Hexagonal screw | | 4 | A2 |
| 52A | Hexagonal screw | | 4 | A2 |
| 52B | Hexagonal screw | | 20 | A2 |
| 52C | Hexagonal screw | | 4 | A2 |
| 52D | Hexagonal screw | | 3 | A2 |
| 52E | Hexagonal screw | | 1 | A2 |
| 52F | Hexagonal screw | | 4 | A2 |
| 53 | Flat washer | | 10 | A2 |
| 53A | Flat washer | | 20 | A2 |
| 53B | Flat washer | | 4 | A2 |
| 53C | Grower washer | | 4 | A2 |
| 53D | Grower washer | | 1 | A2 |
| 53F | Grower washer | | 4 | A2 |
| 54 | Hexagonal nut | | 14 | A2 |
| 54A | Hexagonal nut | | 23 | A2 |
| 54C | Hexagonal nut | | 1 | A2 |
| 55 | Pin | | 4 | A2 |
| 56 | Flexible pin | | 2 | F-143 |
| 61 | Key | | 2 | F-114 |
| 61A | Key | | 1 | F-114 |
| 61B | Key | | 2 | F-114 |
| 64 | Rotating guide bushing | * | 2 | Brass |
| 64A | Blade guide bushing | * | 4 | PTFE |
| 64B | Intermediate pinion bushing | * | 1 | Brass |
| 64C | Connecting rod guide bushing | * | 1 | Brass |
| 66 | Elastic ring | | 2 | Steel |
| 66A | Elastic ring | | 2 | Steel |
| 66B | Self-locking ring | | 4 | Steel |
| 67 | Tightening knob | | 2 | Plastic |
| 76 | Fixed wheel | | 2 | Nylon |
| 81 | Stopper gasket | | 1 | PTFE + glass |
| 83 | Grease nipple | | 3 | A2 |
| 84 | Valve stopper | * | 2 | NBR |
| 87 | Stopper | | 1 | A4 |
| 88 | Lock | * | 4 | NBR |
| 88A | Lock | * | 2 | NBR |
| 93 | Gearbox drive | | 1 | - |

(*) Recommended spare parts

Насосы для виноделия — Перистальтические насосы PV PVD PVT PVDT

<http://k-tep.com.ua/>

✉ k-tep@ukr.net

☎ Office +38(044)2091823

☎ МТС +38 066 9076563

☎ Киевстар +38 098 3676414

Skype: [k-teppumps](#)

Замечания

Условия поставки: DDP склад г. Киев

Заметки

Время поставки рассчитано согласно дате предложения и изменяется в зависимости от даты подтверждения заказа.

Размещая заказ, покупатель принимает предложение и все спецификации, характеристики и условия, указанные в данном документе.