

**INSTALLATION, SERVICE AND MAINTENANCE
INSTRUCTIONS**

**PROGRESSIVE CAVITY PUMP
KIBER KSF KSFT**



c/Telers, 54 Apto. 174
E-17820 Banyoles
Girona (Spain)



Original Manual
01.611.30.06EN
(0) 2013/10

EC DECLARATION OF CONFORMITY

The manufacturer:

c/ Telers, 57
17820 Banyoles (Girona), Span

herewith declares that the machine:

KIBER KSF – KSFT Progressive Cavity pump

with the serial number: _____

conforms to the relevant provisions of the following directives:

Machinery Directive 2006/42/EC (RD 1644/2008)
Low voltage Directive 2006/95/EC
Electromagnetic Compatibility Directive 2004/108/EC

Applicable harmonised Standards:

UNE-EN ISO 12100:2012
UNE-EN 809:1999+A1:2010

In compliance with Regulation (EC) 1935/2004 relating to materials and articles intended to come into contact with food, the materials in contact with the product do not transfer their constituents to the product in quantities which could endanger human health.

Identification of the person empowered to draw up the Declaration on behalf of the manufacturer, and qualified to compile the technical file established by the Community:

Banyoles, 21 September 2014



David Reyer Brunet
Technical Office Manager

1. Safety

1.1. INSTRUCTIONS MANUAL

This manual contains information about the reception, installation, operation, assembly, disassembly and maintenance of the KIBER KSF / KSFT pumps.

The information provided in this Instructions Manual is based on updated facts. INOXPA reserves the right to modify this Instructions Manual without prior notice.

1.2. START-UP INSTRUCTIONS

This Instructions Manual contains vital and useful information for properly operating and maintaining your pump.

Read carefully these instructions before starting up the pump; become familiar with the operation and use of your pump and follow the instructions closely. It is very important that a copy of these Instructions is kept in a set place near the plant.

1.3. SAFETY

1.3.1. Warning signs



General danger of injury



Danger of injuries caused by the rotary parts of the equipment.



Electrical hazard



Danger! Caustics or etching materials



Danger! Suspended load



Danger of equipment malfunction



Compulsory requirement to ensure safety at work



Use of goggles is compulsory

1.4. GENERAL SAFETY INSTRUCTIONS



Read carefully this Instructions Manual before installing the pump and starting it up. If in doubt, contact INOXPA.

1.4.1. During installation



Always observe the *Technical Specification* given in Chapter 8.

Never start up the pump before it has been connected to the piping.

Check that the motor specifications are the required ones, especially when working under conditions that involve the risk of explosion.



During the installation of the pump, all the electrical work must be carried out by an authorized operative.

1.4.2. During operation



Always observe the *Technical Specification* given in Chapter 8. NEVER exceed the limit of the specified values.

NEVER touch the pump or the pipes during operation when the pump is being used to decant hot fluids or when it is being cleaned.



The pump contains moving parts. Never introduce your fingers into the pump while the pump is in operation.



NEVER operate the pump with the inlet and discharge valves closed.

NEVER spray the electrical motor directly with water. The standard protection of the motor is IP- 55: Protection against dust and spraying water.

1.4.3. During maintenance



Always observe the *Technical Specification* given in Chapter 8.

NEVER disassemble the pump before the pipes have been emptied. Remember that some of the fluid will always remain in the pumpcasing (when no drainage is provided). Note that the pumped fluid may be dangerous or very hot. Please refer to the regulations applicable in the respective country.

Do not leave detached parts on the floor.



ALWAYS disconnect the pump from the power before beginning the maintenance. Remove the fuses and disconnect the cables from the motor terminals.

All the electrical work must be carried out by an authorized operative.

1.4.4. Compliance with the instructions

Any failure to comply with the instructions might entail risks to the operators, the environment and the equipment, and result in the loss of the right to claim for damages.

Such non-compliance might entail the following risks:

- Failure of important functions of the equipment / plant.
- Failure of specific maintenance and repair procedures.
- Threat of electrical, mechanical and chemical risks.
- Environmental risks caused by the release of substances.

1.4.5. Warranty

Any warranty provided shall immediately and *ipso jure* become void, and INOXPA shall be indemnified against any product liability claim from third parties, if:

- the service and maintenance work was not carried out in accordance to the service instructions, or the repair work has not been carried out by our personnel or it has been carried without our written authorization;
- our materials have been changed without prior written authorization;
- the parts or lubricants used are not original INOXPA parts and products;
- the materials were used improperly or carelessly, or not in accordance to these instructions and their intended use;
- pump parts were damaged by strong pressure for lack of a safety valve.

The General Delivery Terms already furnished to you also apply.



No change can be made to the equipment without prior discussion with the manufacturer. For your safety, please use original spare parts and accessories.

The use of other parts will release the manufacturer from any liability.

The service terms can only be changed with prior written authorisation from INOXPA.

When in doubt, or if you need more detailed information on specific matters (adjustment, assembly, disassembly, etc.), please do not hesitate to contact us.

2. Index

1. Safety	
1.1. Instructions manual.....	3
1.2. Start-up instructions.....	3
1.3. Safety.....	3
1.4. General safety instructions.....	3
2. Index	
3. General information	
3.1. Description.....	6
3.2. Range of applications.....	6
4. Installation	
4.1. Reception of the pump.....	7
4.2. Handling and storage.....	7
4.3. Location.....	8
4.4. Pipes.....	8
4.5. Pressurisation tank.....	8
4.6. Electric wiring.....	9
5. Start-up	
5.1. Start-up.....	10
5.2. By-pass pressure.....	10
6. Operating problems	
7. Maintenance	
7.1. General.....	12
7.2. Storage.....	12
7.3. Cleaning.....	12
7.4. Disassembly / Assembly of the pump.....	13
8. Technical specifications	
8.1. Technical specifications.....	18
8.2. Weights.....	19
8.3. Pump dimensions with by-pass pressure.....	19
8.4. KSF pump dimensions.....	20
8.5. Dimensiones bomba KSFT.....	21
8.6. KSF pump.....	22
8.7. Parts list KSF.....	23
8.8. Despiece bomba KSFT.....	24
8.9. Parts list KSFT.....	25
8.10. Heavy duty transmission.....	26
8.11. Cooled mechanical seal.....	27
8.12. Double mechanical seal.....	28
8.13. Gland packing.....	29

3. General information

3.1. DESCRIPTION

With a compact and robust design, INOXPA's KSF/KSFT progressive cavity pumps form part of our range of positive-displacement pumps with helical rotor, intended for viscous fluids.

The hydraulic parts that form the pump are the rotor and the stator. The rotor is a round-section worm. The stator has two ribs and its pitch doubles that of the rotor, thus allowing empty cavities between the stator and the rotor. These cavities are used to transport the fluid. When the rotor turns within the stator, the cavities move longitudinally from the suction area to the discharge nozzle.

These kinds of pumps are suitable for pressures from 6 bar (single-stage stator) to 12 bar (double-stage stator).

KSF pumps are designed with a fully health-compliant and easy-to-clean transmission. For KSFT, bolts are fixed through some countersink. The standard connections are DN 11851. The discharge nozzle is eccentric.

Moreover, there is a more robust design of transmission for a longer service life under heavy duty working conditions.

Also it is possible to choose other types of connections for the pump, like the CLAMP, SMS, RJT, flanges DIN-2633 PN-16, etc.

All pump parts in contact with the pumped product are manufactured in AISI 316L stainless steel. The stator is manufactured in NBR, according to the FDA norm, and the standard sealing is EN 12756 L₁K mechanical seal.

This equipment is suitable for his use in food process.

3.2. RANGE OF APPLICATIONS

The curves shown below are valid for both the single- and double-stage stators.

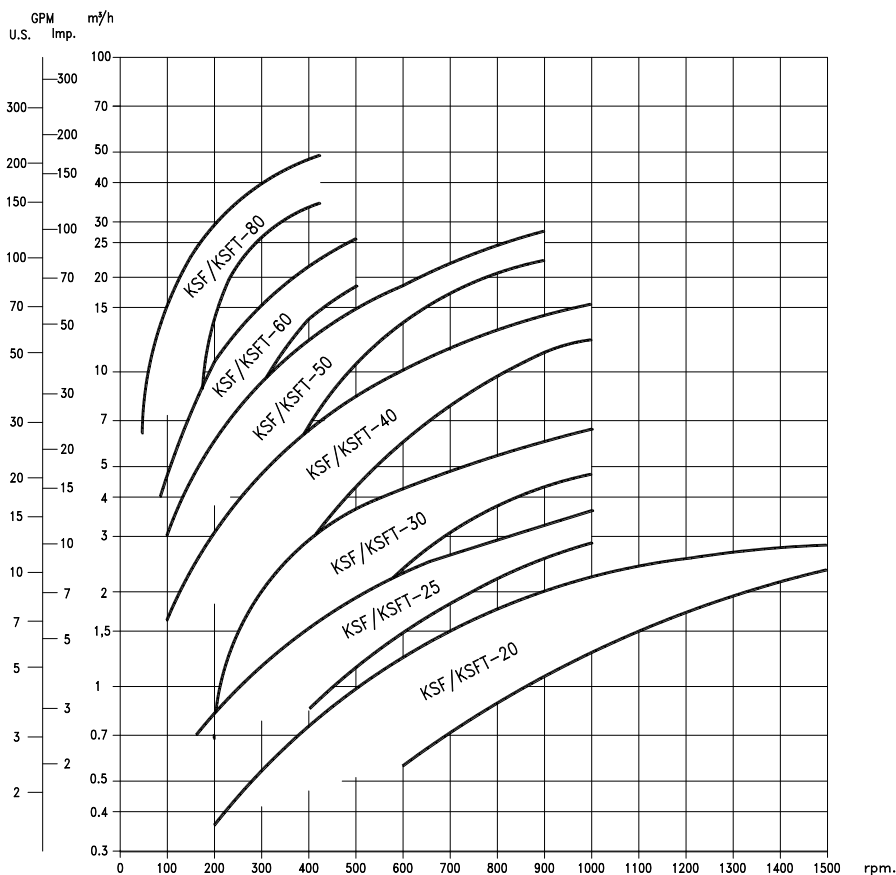

The range of application for each type of pump is limited. The pump was selected for a given set of pumping conditions when the order was placed. INOXPA shall not be liable for any damage resulting from the incompleteness of the information provided by the purchaser (nature of the fluid, RPM, etc.).

4. Installation

4.1. RECEPTION OF THE PUMP



INOXPA cannot be held responsible for the damage sustained by the equipment during transport or unpacking. Please visually check that the packaging is not damaged.

The pump package includes the following documents:

- Dispatch sheets.
 - Instructions and Service Manual of the pump.
 - Instructions and Service Manual of the motor (*)
- (*) when the pump is supplied with an motor by INOXPA.

Unpack the pump and check the following:

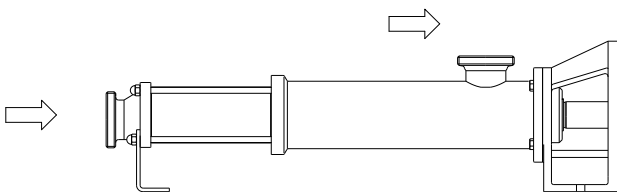

- The suction and discharge connections of the pump, removing any rest of packaging materials.
- The pump and the motor are not damaged.
- If the equipment is not in good condition and/or any part is missing, the carrier should report accordingly as soon as possible.

4.1.1. Identification of the pump

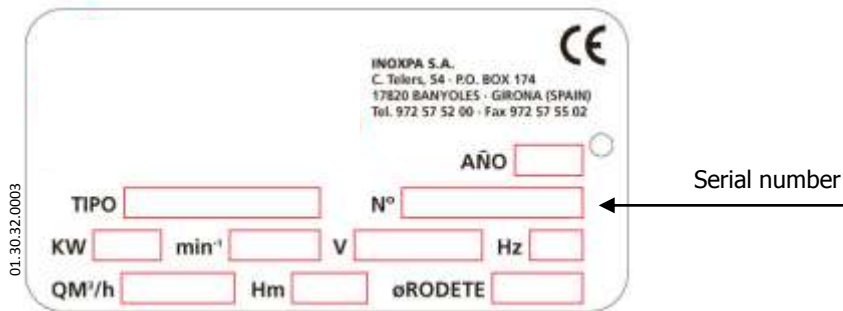

Pump plate

4.2. HANDLING AND STORAGE



KSF / KSFT pumps are often too heavy to be handled and stored manually.

Lift the pump as shown below:

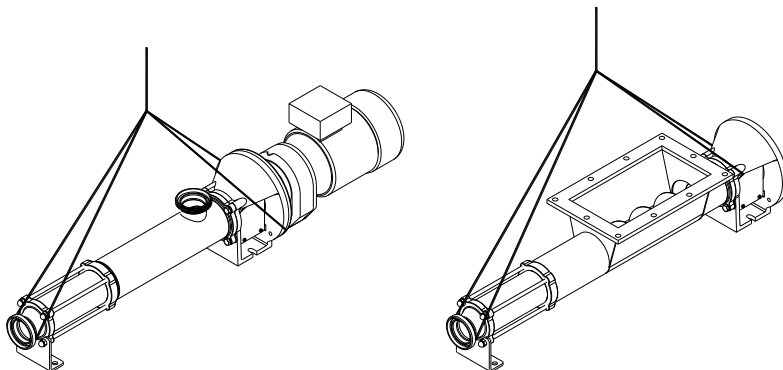

- Always use two support points placed as far apart as possible.
- Secure the supports so that they will not move.

4.3. LOCATION

Place the pump as close as possible to the suction tank, and if possible below the fluid level.

Place the pump so as to allow around it space enough to access the pump and the motor. (See Chapter 8 [Technical Specification](#) for dimensions and weight).

Mount the pump on a flat, level surface.

The foundation must be rigid, horizontal, level and vibration-proof.



Install the pump so as to allow proper ventilation.

If the pump is installed outdoors, it should be covered by a roof. Its location should allow easy access for inspection or maintenance operations.

4.4. PIPES

- As general rule, fit the suction and discharge pipes in straight sections, with the least possible number of bends and accessories in order to reduce as much as possible any loss of load caused by friction.
- Make sure that the nozzles of the pump are properly aligned to the pipe and their diameter is similar to that of the pump connections.
- Place the pump as close as possible to the suction tank, if possible below the fluid level, or even below the tank, so that the manometric head of the static suction is highest.
- Place pipe supports as close as possible to the suction and discharge nozzles of the pump.

4.4.1. Cut-off valves

The pump can be isolated for maintenance purposes. To such end, cut-off valves must be fitted to the suction and discharge nozzles of the pump.

These valves must ALWAYS be open during operation of the pump.

4.5. PRESSURISATION TANK

For models with a mechanical seal, a pressurisation tank needs to be fitted.



ALWAYS install a pressurisation tank 1 to 2 meters above the pump shaft. See Figure 4.6.

ALWAYS connect the cooling fluid inlet to the lower connection of the seal chamber. Therefore, the outflow of the cooling liquid will be through the upper connection of the chamber. See Figure 4.6.

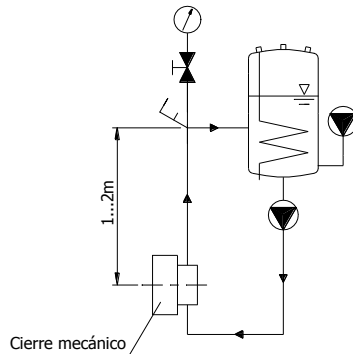

Figure 4.6: Pressurisation tank installation sketch

For more information on the pressurisation tank (installation, operation, maintenance, etc.), see the manufacturer's instructions manual.

4.6. ELECTRIC WIRING



The connection of the electrical motors must be performed by a qualified operative. Take all necessary precautions to prevent the failure of connections and cables.



The electrical equipment, the terminals and the components of the control systems may still bear electrical current when powered off. Contact with them may be dangerous for operators or cause irreversible damage to equipment.

Before handling the pump, Make sure that the motor is fully disconnected from the power.

- Connect the motor following the manufacturer's instructions.
- Check the direction of rotation (see the label on the pump).
- Start the pump motor briefly. Make sure the pumping direction is the right one. If the pump operates in the wrong direction it may cause severe damage.

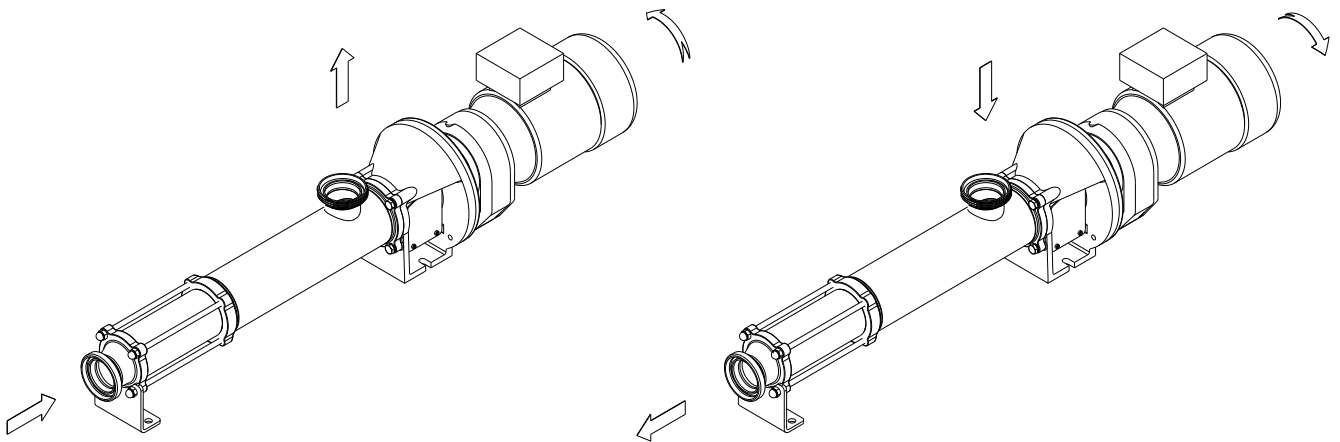

ALWAYS check the direction of rotation of motor with fluid inside de pump.

For models with a seal chamber, ALWAYS make sure that the chamber is full of fluid before checking the direction of rotation.

5. Start-up



Before starting the pump, carefully read the instructions given in Chapter 4. *Installation*.

5.1. START-UP



Read Chapter 8 *Technical Specification* carefully. INOXPA cannot be held responsible for the improper use of the equipment.



NEVER touch the pump or the pipes when hot fluid is being pumped.

5.1.1. Checks before starting up the pump

- Fully open the cut-off valves on the suction and discharge pipes.
- If the fluid does not flow into the pump, fill the pump with fluid.



The pump must **NEVER** rotate without fluid inside it.

- Check that the power supply matches the rating indicated on the motor plate.
- Check that the direction of rotation of motor is the right one.
- If the pump has a double or a cooled mechanical seal, mount the auxiliary connection corresponding to the values indicated in Chapter 8, *Technical Specification*.

5.1.2. Checks when starting up the pump

- Check whether the pump makes strange sounds.
- Check whether the absolute inlet pressure is enough to avoid cavitation in the pump. See the curve to determine the minimum pressure required above steam pressure (NPSHr).
- Control discharge pressure.
- Check that there are no leaks through the sealed areas.



A cut-off valve on the suction pipe must no be used to regulate flow. Cut-off valves must be fully open during operation.



Control motor consumption to avoid power overload.

Reduce flow and motor power consumption by reducing motor speed.

5.2. BY-PASS PRESSURE

If the pump has an incorporated pressure by-pass, the rotation can be of only one direction. To invert the direction of rotation, mount an overflow valve as indicated the next figure. The single stage pump has the overflow valve calibrated at 6 bar and at 10 bar for the double stage ones. In both cases this is the maximum pressure.

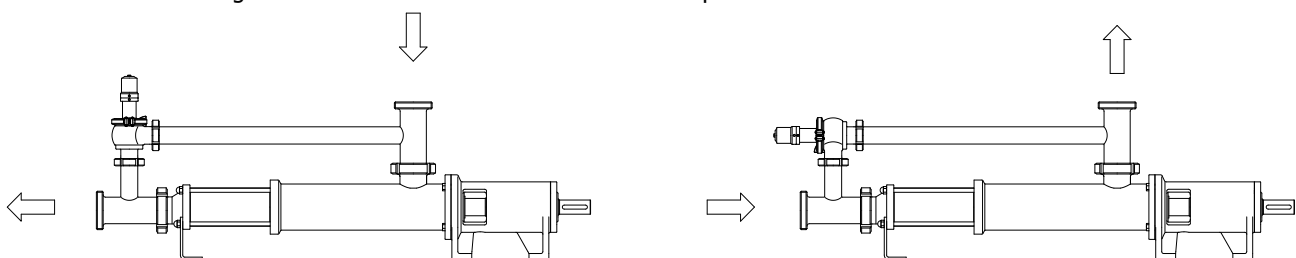

The pump always leaves INOXPA with by-pass mounted to work with the aspiration in the pump casing and the impulsion ahead.

6. Operating problems

The following table provides solutions to problems that might arise during the operation of the pump. The pump is assumed to have been properly installed and be suitable for the relevant application. Please contact INOXPA if technical assistance is required.

Operating problems	Probable causes
Motor overload	8, 9, 13, 19.
The pump does not provide enough flow or pressure	1, 2, 4, 5, 7, 9, 10, 16, 17,18.
No pressure on the discharge side	2, 3, 6, 17, 17.
Uneven discharge flow / pressure	1, 2, 4, 5, 6, 9, 20.
Noise and vibration	2, 4, 5, 6, 7, 8, 9, 10, 13, 14, 18, 19.
The pump gets clogged	9, 10, 14, 19.
Overheated pump	8, 9, 10, 14, 19.
Excessive wear	4, 5, 10, 14, 18.
The mechanical seal leaks	11, 12, 15.

Probable causes	Solutions
1 Wrong direction of rotation	Reverse the direction of rotation
2 NPSH is not high enough	Increase the available NPSH: - Place the suction tank higher - Place the pump lower - Reduce steam pressure - Increase the diameter of the suction pipe - Shorten and simplify the suction pipe
3 Pump not drained	Drain or fill
4 Cavitation	Increase suction pressure (see also 2)
5 Air is suctioned by the pump.	Check the suction pipe and all its connections
6 Clogged suction pipe	Check the suction pipe and all its filters, if any
7 Discharge pressure too high	If necessary, reduce load losses, e.g. by increasing the diameter of the pipe
8 Flow too high	Reduce speed
9 Fluid viscosity too high	Reduce the viscosity, e.g. by heating the fluid
10 Fluid temperature too high	Reduce the temperature by cooling the fluid
11 Mechanical seal damaged or worn out	Replace the seal
12 O-rings unsuitable for the fluid	Fit suitable O-rings. Consult the manufacturer.
13 Stressed pipes	Connect the pipes to the pump so as to avoid stress and align the coupling
14 Foreign matter in the fluid	Fit a filter to the suction pipe
15 The mechanical seal tension is too low	Adjust according the instructions of this Manual
16 Pump speed too low	Increase speed
17 Pump too small	Choose a larger pump size
18 The stator is worn out or has operated in vacuum	Replace the stator
19 Pump and/or motor not attached to the bedplate.	Attach the pump and/or motor and check whether the pipes are connected without stress
20 Flow reduction	Replace the worn stator



If the problem persists, use of the pump must cease immediately. Contact the pump's manufacturers or their representative.

7. Maintenance

7.1. GENERAL

Like any other machine, this pump requires maintenance. The instructions included in this manual cover the identification and replacement of spare parts. These instructions are intended for the maintenance personnel and those responsible for the supply of spare parts.



Please carefully read Chapter 8 *Technical specification*.

All replaced materials must be disposed of /recycled in accordance to the applicable local regulations.



ALWAYS disconnect the pump from the power before performing the maintenance.

7.1.1. Check the mechanical seal

Regularly check that there are no leaks in the shaft area. If there are leaks through the mechanical seal, replace it following the instructions given under the *Disassembly and Assembly* section.

7.2. STORAGE

The pump must be completely emptied of fluid before storage. If possible, avoid exposing the components of the pump to excessively humid environments.

7.3. CLEANING



The use of aggressive cleaning products, such as caustic soda and nitric acid, can cause skin burns.

Use rubber gloves during cleaning procedures.



Always use protective goggles.

7.3.1. Automatic CIP (cleaning-in-place)

If the pump is installed in a system with a CIP process, it is not necessary to disassemble the pump.

If the automatic cleaning process is not provided, proceed to disassemble the pump as indicated in the *Disassembly and Assembly* section.

Cleaning solutions for CIP processes

Use only clear water (without chlorides) for mixing with the cleaning agents:

a) Alkaline solution: 1% in weight of caustic soda (NaOH) at 70°C (150°F)

1 Kg NaOH + 100 l. water = cleaning solution

or

2,2 l. NaOH at 33% + 100 l. water = cleaning solution

b) Acid solution: 0,5% in weight of nitric acid (HNO₃) at 70°C (150°F)

0.7 liters HNO₃ at 53% + 100 l. water = cleaning solution



Control the concentration of the cleaning solutions to avoid deterioration of the pump seals.

To remove the remaining cleaning products, ALWAYS perform a final rinse with clean water on completion of the cleaning process.

7.3.2. Automatic SIP (sterilization-in-place)

The process of sterilization with steam is applied to all the equipment including the pump.



Do NOT start the pump during the process of sterilization with steam.
The parts/materials suffer no damage if the indications specified in this manual are observed.

No cold liquid can enter the pump till the temperature of the pump is lower than 60°C (140°F).

A flow by-pass is recommended to be used in order to assure the flow of sterile product after the pump.

Maximum conditions during the SIP process with steam or overheated water

a)	Max. temperature:	140°C / 284°F
b)	Max. time:	30 min
c)	Cooling:	Sterile air or inert gas
d)	Materials:	EPDM / PTFE (recommended) FPM / NBR (not recommended)

7.4. DISASSEMBLY / ASSEMBLY OF THE PUMP

7.4.1. Stator, rotor and connecting rod

7.4.1.A Standard transmission for KSF / KSFT

⇐ Disassembly

Loosen the nuts (54) and remove the leg (07) and the discharge nozzle (34). Pull out the tie bars (29/29A) and then remove the stator (22); if necessary secure the rotor (21) by holding the shaft complement (26). Remove the screws (52) and the washers (53). Pull out the pump casing (01/01A) from the front side. For KSF, remove the safe ring (30) and the bolt (27) so that the rotor (21) comes out. . And for KSFT, remove the screws (50), washers (35), and the bolt (27) to take out the rotor (21) too. Proceed likewise on the other end of the connecting rod (24/24A) in order to remove it.

⇒ Assembly

For the KSF model, connect the connecting rod (24) to the shaft complement (26) with the bolt (27) and attach the bolt with the safe ring (30). For the KSFT, connect the feeder screw (24A) to the shaft with the bolt (27) that will be attached with the screws (50), washers (35) and adds some industrial adhesive LOCTITE 270 to ensure that the screws (50) don't loosen. Proceed likewise with the rotor on the other end of the connecting rod (21). Mount the pump casing (01/01A) and fasten it with the screws (52) and the washers (53). Introduce the stator (22) lubricating it with soapy water and if necessary secure the rotor (21) by holding the shaft complement (26). Mount the discharge flange (34) and the leg (07) and fasten it with the nuts (54).

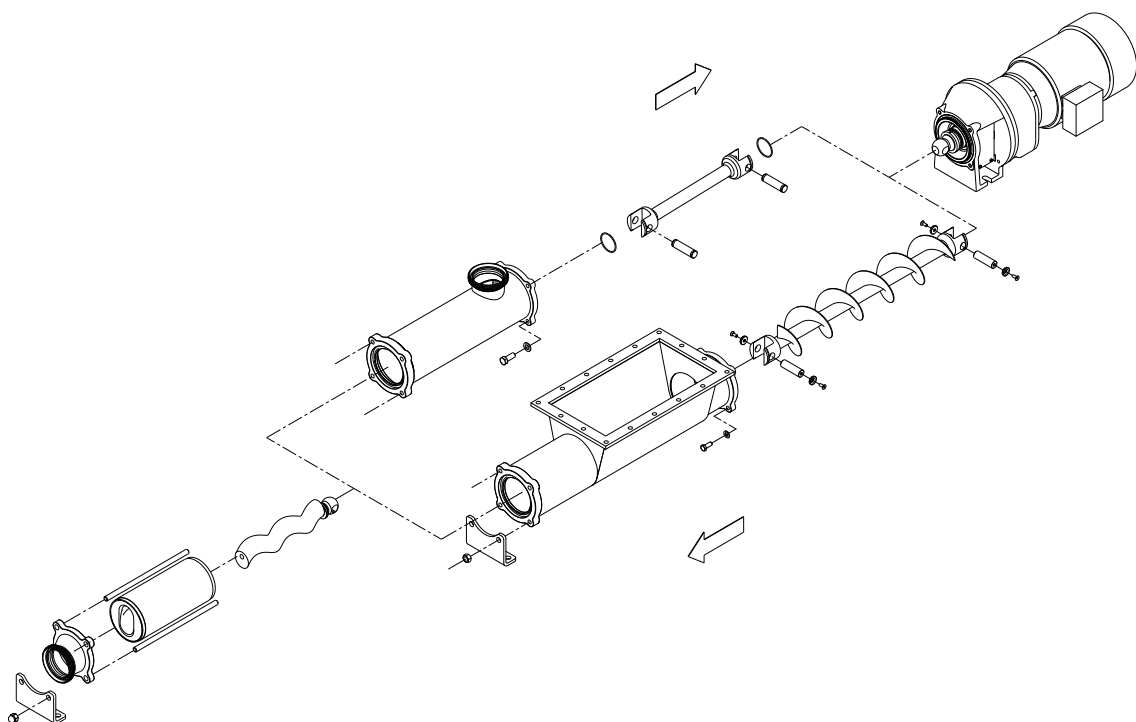

7.4.1.B Heavy duty transmission (only optional for KSF)

← Disassembly

Loosen the nuts (54) and remove the leg (07) and the discharge nozzle (34). Pull out the tie bars (29/29A) and then remove the stator (22); if necessary secure the rotor (21) by holding the shaft complement (26). Remove the screws (52) and the washers (53). Pull out the pump casing (01/01A) from the front side. Remove the safe rings (30), the transmission shield bushing (17A) and the bolts (27), so that the rotor (21) and one end of the connecting rod (24/24A) come out. Proceed likewise on the other end of the connecting rod in order to remove it.

⇒ Assembly

Place the O-ring (81) on the pump shaft (05) / shaft complement (26) and on the connecting rod (24), and the seals (80A) on the transmission bushing (43). Place this bushing on the shaft complement (26) and place the drive bolt (27) and the bolt for the connecting rod. Place the transmission shield bushing (17A) on the bushing (43) and fasten it with the safe rings (30). Proceed likewise with the rotor on the other end of the connecting rod (21). Mount the pump casing (01) and fasten it with the screws (52) and the washers (53). Introduce the stator (22) lubricating it with soapy water and if necessary secure the rotor (21) by holding the shaft complement (26). Mount the discharge flange (34) and the leg (07) and fasten it with the nuts (54).

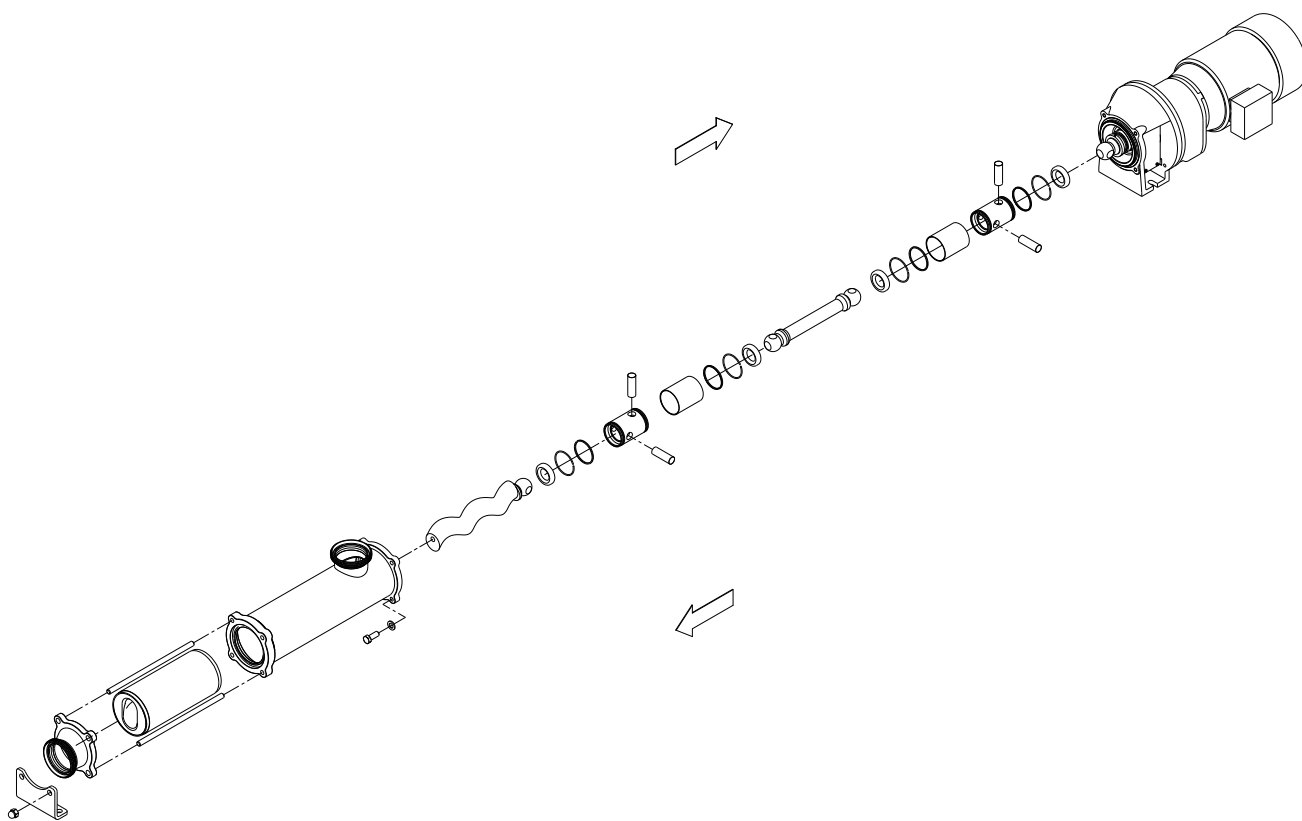

7.4.2. Mechanical seal

← Disassembly

First follow the disassembly procedure described in the preceding section. If the protections (47A) were not removed previously, remove them now. Loosen the pins (55) to remove the seal ring (31). Remove the seal cover (09) to pull out the seal at the same time as the mechanical seal (08). Finally, gently remove the stationary part of the seal, which has remained housed inside the seal cover.

⇒ Assembly

Mount the fixed part of the mechanical seal (08) and the O-ring (80) to the seal cover (09). Place the cover on the flange support (06A). Slide the rotary part of the seal (08) into the shaft complement (26). Place the seal ring (31) on the shaft and fasten it with the pins (55) according to the following assembly dimension.

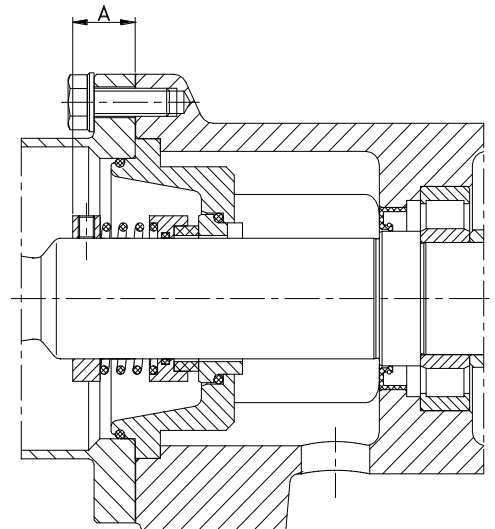
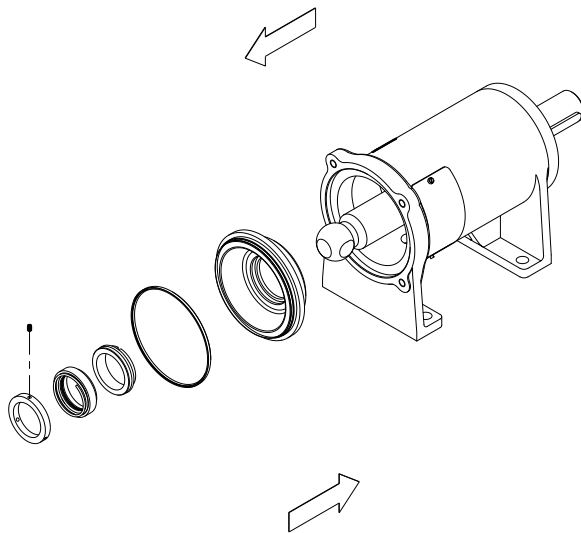

Pump type	A
KSF-20	12
KSF-25/30	16.5
KSF-40/50	23
KSF-60/80	25.5

CAUTION! When mounting the new seal, plunge the parts and seals in soapy water to facilitate sliding of both the stationary and the rotary parts.

7.4.3. Cooled mechanical seal

← Disassembly

First follow the disassembly procedure described in section 7.4.1. If the protections (47A) were not removed previously, remove them now. Remove the raccords (92) of the cover (09A). Loosen the pins (55) to remove the seal ring (31). Remove the seal cover (09A) to pull out the seal at the same time as the mechanical seal (08) and the lip seal (88B). Finally, gently remove the stationary part of the seal, which has remained housed inside the seal cover and the lip seal.

→ Assembly

Mount the fixed part of the mechanical seal (08), the lip seal (88B), the O-ring (80) and the raccords (92) to the seal cover, the quenching liquid pipes can be connected to the connections through the bearing support windows (09A). Place the cover on the flange support (06A). Slide the rotary part of the seal (08) into the shaft complement (26). Place the seal ring (31) on the shaft and fasten it with the pins (55) according to the A dimension showed in section 7.4.2..

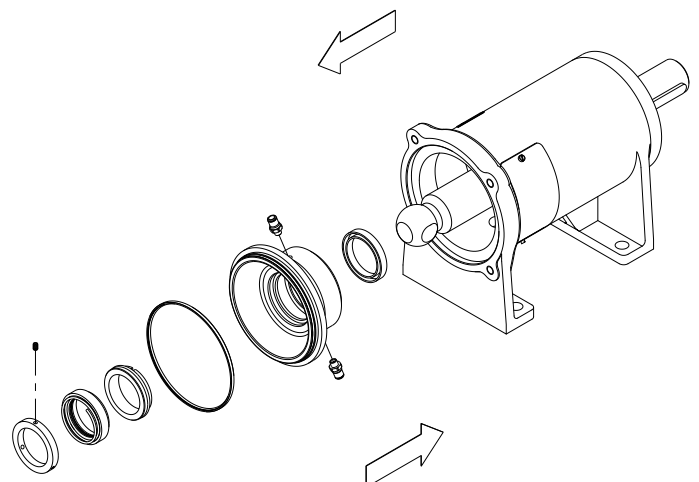
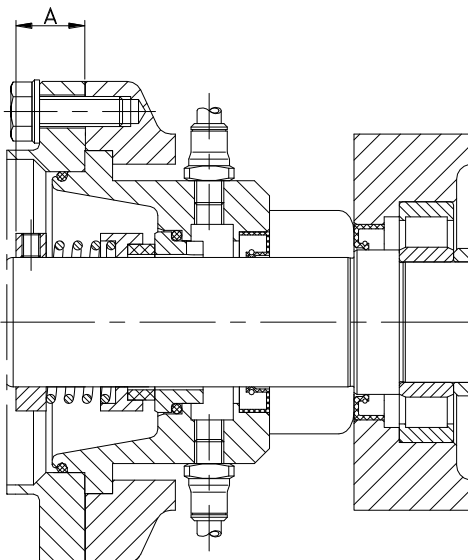

7.4.4. Double mechanical seal

← Disassembly

First follow the disassembly procedure described in section 7.4.1. First remove the protections (47A). Remove the nuts (54A); now the cap of the double seal is loose (10A). Remove the seal cover (10), the fixed part of the inside seal (08A) will remain housed inside the cap (10A). Loosen the pins (55) and, when appropriate, the pins that hold the two rotary parts of the seals and then remove these rotary parts of the seals (08A and 08B) and the seal ring (31). Remove the seal cap (10A), the fixed part of the outside mechanical seal (08A) will remain housed inside the cover.

⇒ Assembly

Place the fixed part of the outside mechanical seal (08B) in its housing inside the back cover of the double seal (10A). Insert this cover (10A), leaving it loose at the end of pump shaft (05A). Slide the rotary part of the outside mechanical seal (08B) and the seal ring (31) (only for KS-60/80), and fasten it with the pins (55) according to the assembly dimension shown in the following table. Mount the rotary part of the inside seal (08A) to the ring (31).

Place the fixed part of the inside seal (08B) into its housing inside the seal cover (10). Mount the cover (10) to the flange support (06A) having previously laced the O-rings (80-80B), and fasten it with the back cover of the double seal (10A) using the pins (55A) and nuts (54A).

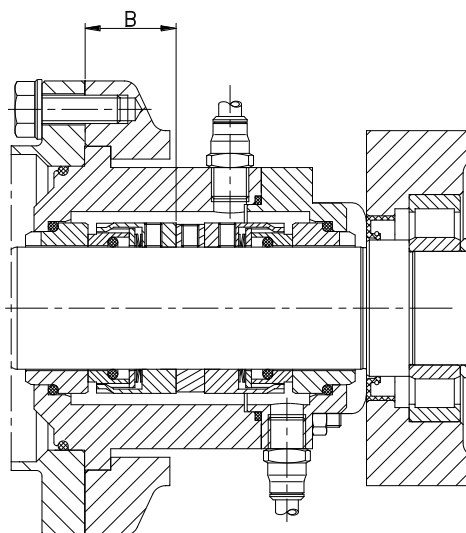
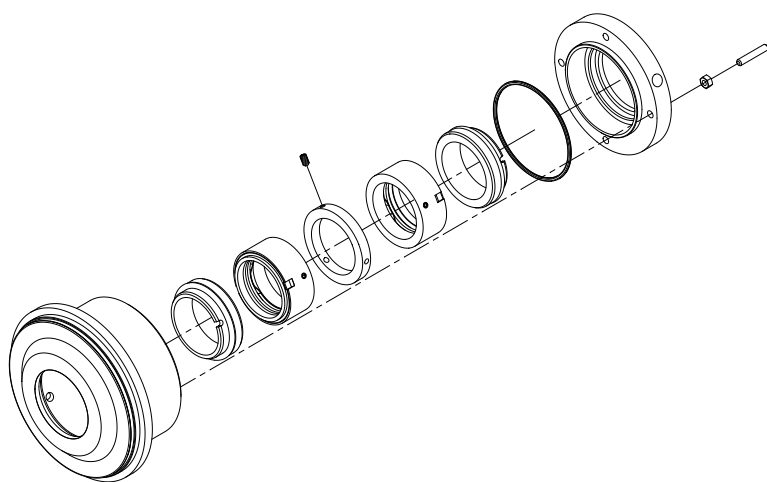

Pump type	B
KSF-20	-
KSF-25/30	35.5
KSF-40/50	32
KSF-60/80	31.5

7.4.5. Gland packing

← Disassembly

First follow the disassembly procedure described in section 7.4.1. Remove the packing from the packing box (36) with the gland (37) from the front side. Once the packing has been removed, remove the gland (37) by loosening the nuts (57). Proceed to replace the gland packing rings (08C).

⇒ Assembly

Before introducing the new gland packing, check the condition of the surface of the driving shaft (05) and the packing box (36). The shaft should have a polished surface finishing. Cut the rings to the required length with a 45° angle, as shown in Figure 7.1. Check that the cuts match on the shaft. Gently open the rings (Figure 7.2) to allow the passage of the shaft, and place each of the term in turn. First insert the junction and then push the rings to the end.

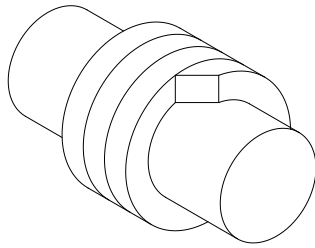
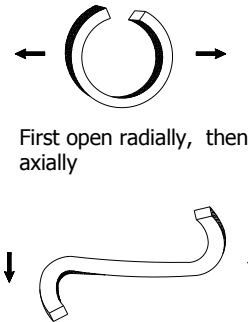

Figure 7.1



First open radially, then axially

Figure 7.2

The rings (08C) must be in contact with each other, and the cuts of each ring must be arranged against each other forming a 120° angle. Insert the gland packing (37) and fit the pins (55A) and nuts (57) avoiding to fasten them excessively. Mount this assembly to the shaft (05). Turn the drive shaft (55) from time to time to facilitate the settlement of the rings. Fasten the nuts (57) manually and evenly, and make sure that the shaft rotates freely. Now follow the assembly procedure described in section 7.4.1.

Let the pump operate with constant leaks for about 10 minutes, then fasten the gland (37) using the nuts (57) until the leaks are reduced to an acceptable level (15 to 20 drops/minute). A dripping leak is essential for the normal operation of the gland packing in order to avoid the overheating of the screws.

When the packing has become fully compressed after successive adjustments, replace the full contents of the box (never replace the packing only partially). Always use good-quality packing.

7.4.6. Change of drive

⇐ Disassembly

Remove the elastic pin (05) from the shaft complement (26).

Remove the screws (52A) and the washers (93) and pull out the drive (93).

⇒ Assembly

Drill a hole in the drive shaft as shown in the figure below. Mount the drive (93) to the flange support (06A) and fasten it with the screws (52A) and washers (53A). Slide the shaft complement (26) over the drive shaft (93) and fasten it with the pin (56).

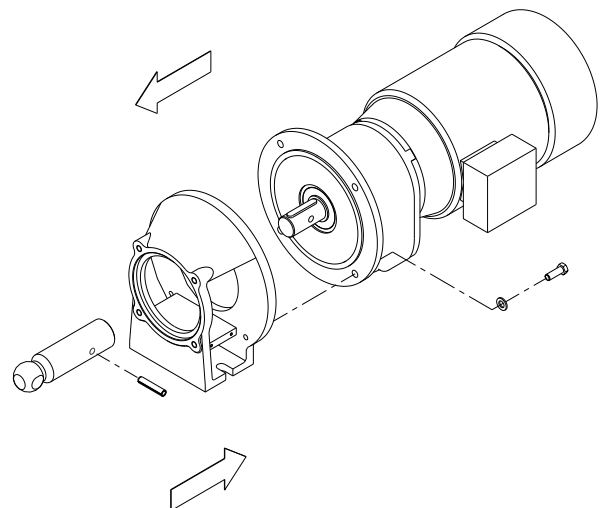
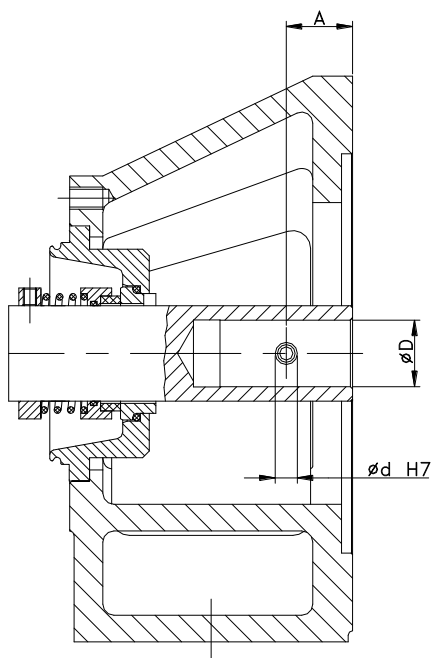

Pump type	A	ØD	Ød
KSF-20	20	19/20 24	6 8
KSF-25/30	20	24/25/28	8
KSF-40/50	30	24/25/28/30	8
KSF-60/80	35	35/38 40/42	10 12

8. Technical specifications

8.1. TECHNICAL SPECIFICATIONS

Maximum viscosity	1,000,000 mPa.s.
Maximum temperature	+85°C (NBR) +185 °F (NBR)
Sound level	60-80 dB(A)
Suction / discharge connections	DIN 11851



Use special protection when the noise level in the operation area exceeds 85 dB(A).

Materials

Parts in contact with pumped material	AISI 316L
Other parts in stainless steel.....	AISI 304
Gaskets in contact with pumped material	NBR
Stator.....	NBR black
Other materials for optional gaskets	Check with the supplier
Surface finishing	Ra 0.8 polished

Mechanical seal

Type of seal	single inside seal
Stationary parts material	ceramic
Rotary parts material	graphite
Seals material	NBR

Cooled mechanical seal

Working pressure.....	0,5 bar (7 PSI) of maximum pressure
Flow rate of the circulation	2,5-5 l/min.

Double mechanical seal

Operating pressure.....	1,5~2 bar (22~29 PSI) above the operating pressure of the pump
-------------------------	--

Gland packing

Packing material	Teflon-reinforced aramid fiber
------------------------	--------------------------------

Pump type	Capacity at 100 rev [l.]	Maximum output [m ³ /h]	Maximum pressure [bar]		Maximum speed [r.p.m.]	Minimum starting torque [Nm.]	
			Single stage	Double stage		Single stage	Double stage
KSF-20			6	12	1450	18	30
KSF-25	6.1	3.5			950	20	36
KSF-30	10.6	6			950	25	45
KSF-40	25.7	14.6			950	45	80
KSF-50	47.2	20.4			720	70	125
KSF-60	86.4	25.9			500	110	190
KSF-80	201.6	48.4			400	150	260

8.1.1. Particles size



Only soft particles can be pumped.

Pump type	Inside diameter of connections [mm]	Maximum nominal sphere size [mm]	Recommended nominal sphere size [mm]
KS-20	35	13	5
KS-25	48	18	6
KS-30	48	24	8
KS-40	60.5	30	10
KS-50	72	40	13
KS-60	97.5	48	16
KS-80	97.5	62	20

8.2. WEIGHTS

Pump type	Weight [Kg]	Pump type	Weight [Kg]	Pump type	Weight [Kg]	Pump type	Weight [Kg]
KSF-20	11	2KSF-20	12	KSFT-20	11	2KSFT-20	12
KSF-25	18	2KSF-25	19	KSFT-25	18	2KSFT-25	19
KSF-30	19	2KSF-30	20	KSFT-30	19	2KSFT-30	20
KSF-40	32	2KSF-40	38	KSFT-40	32	2KSFT-40	38
KSF-50	36	2KSF-50	45	KSFT-50	36	2KSFT-50	45
KSF-60	68			KSFT-60	68		
KSF-80	85			KSFT-80	85		

Pump weight without the dive

8.3. PUMP DIMENSIONS WITH BY-PASS PRESSURE

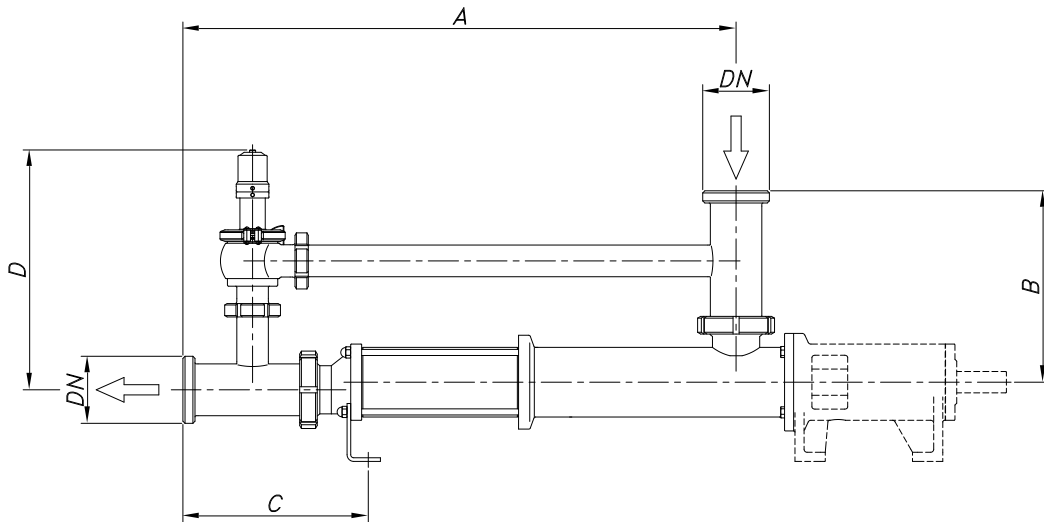

Type	DN	A	B	C	D	Type	DN	A	B	C	D
KSF-20	40	475	230	208	330	2KSF-20	40	575	230	208	330
KSF-25	50	613	262	236	360	2KSF-25	50	705	262	236	360
KSF-30						2KSF-30	763				
KSF-40	65	831	294	277	385	2KSF-40	65	1021	294	277	385
KSF-50	80	913	334	302	420	2KSF-50	80	1167	334	302	420
KSF-60	100	1104	375	339	475						
KSF-80		1224		349							

Connections DIN 11851 (standard)

8.4. KSF PUMP DIMENSIONS

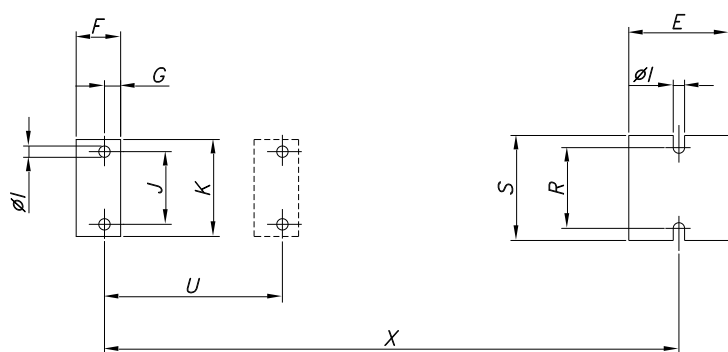
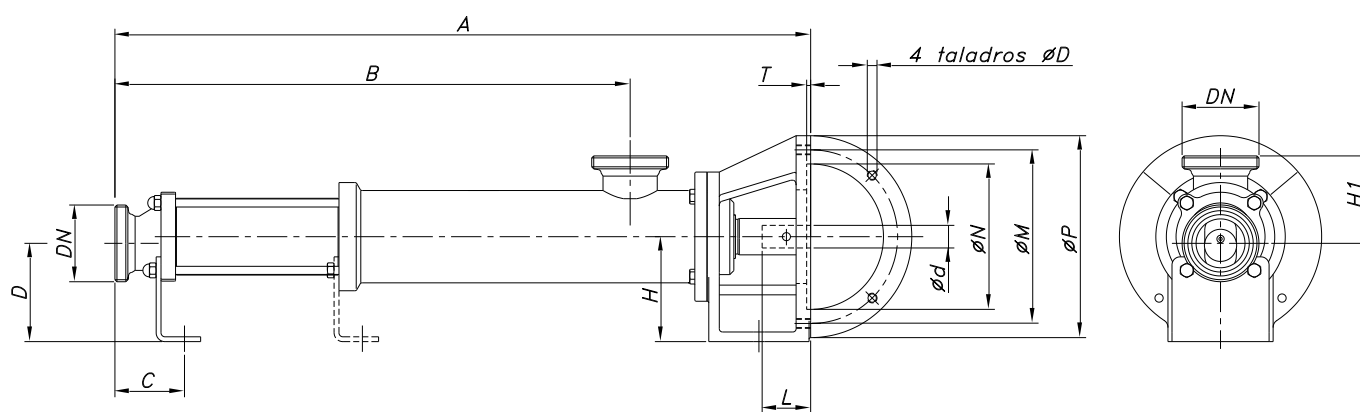

Type	Drive coupling dimensions								
	d		L		D	M	N	P	T
	Min	Max	Min	Max					
KSF-20	19	24	42	52	M8	130	110	160	5
KSF-25	24	28	52	62	M10	165	130	200	5
KSF-30	24	28	52	62	M10	165	130	200	5
KSF-40	24	30	52	72	M12	215	180	250	5
KSF-50	24	30	52	72	M12	215	180	250	5
KSF-60	35	42	72	112	M12	265	230	300	5
KSF-80	35	42	72	112	M12	265	230	300	5

Type	DN	A	B	C	D	E	F	G	H	H1	I	J	K	R	S	U	X
KSF-20	40	489	324	57	87	101	35	12	90	83	11	45	70	70	100	-	381
2KSF-20	1½"	589	424													-	481
KSF-25	50	623	439	62	107	110	40	15	110	93	11	60	90	90	120	-	504
2KSF-25	2"	715	531													-	596
KSF-30	50	623	439	62	104	110	40	15	110	96	11	60	90	90	120	-	504
2KSF-30	2"	773	589													-	654
KSF-40	65	860	637	86	122	124	55	20	130	108	14	90	120	100	130	-	710
2KSF-40	2½"	1050	827													410	900
KSF-50	80	936	713	105	117	124	55	20	130	133	14	90	120	100	130	-	767
2KSF-50	3"	1190	967													534	1021
KSF-60	100	1115	860	100	146	121	60	20	160	149	18	130	170	150	190	-	953
KSF-80	100	1245	990	120	132	121	60	20	160	163	18	150	190	150	190	-	1063

Connections DIN 11851 (standard)

8.5. DIMENSIONES BOMBA KSFT

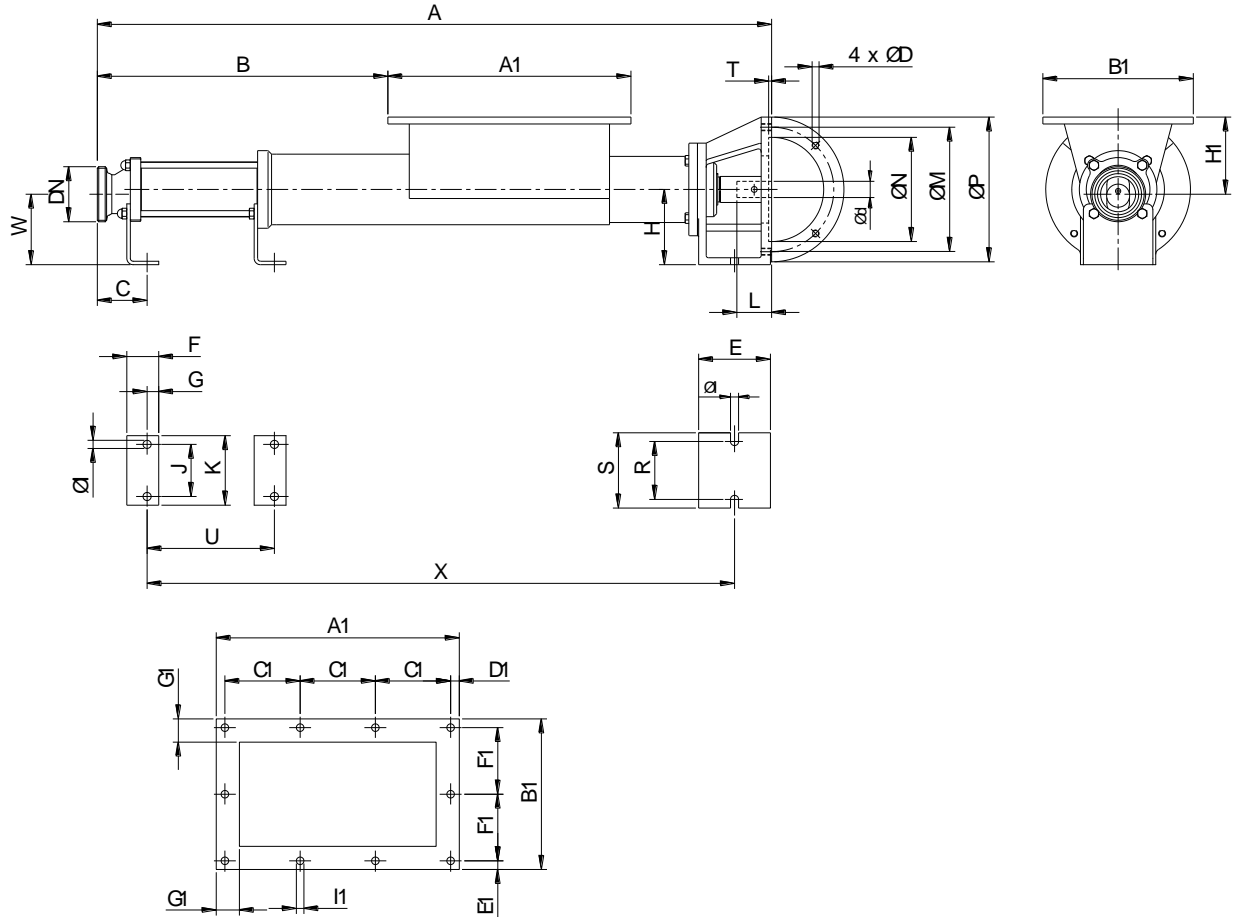

Type	DN	A	B	C	E	F	G	H	H1	I	J	K	R	S	U	X	W
KSFT-20	40	689	244	57	101	35	12	90	88	11	45	70	70	100	105	581	87
2KSFT-20	1½"	789	344												205	681	
KSFT-25	50	858	331	62	110	40	15	110	128	11	60	90	90	120	166	739	107
2KSFT-25	2"	950	423												258	831	
KSFT-30	50	858	331	62	110	40	15	110	131	11	60	90	90	120	166	739	104
2KSFT-30	2"	1008	481												316	889	
KSFT-40	65	1075	452	86	124	55	20	130	133	14	90	120	100	130	223	925	122
2KSFT-40	2½"	1265	642												413	1115	
KSFT-50	80	1151	528	105	124	55	20	130	138	14	90	120	100	130	280	982	117
2KSFT-50	3"	1405	782												534	1236	
KSFT-60	100	1445	643	100	121	60	20	160	174	18	130	170	150	190	330	1283	146
KSFT-80	100	1575	773	120	121	60	20	160	188	18	150	190	150	190	440	1393	132

Connections DIN 11851 (standard)

Type	Drive coupling dimensions								
	d		L		D	M	N	P	T
	Min	Max	Min	Max					
KSFT-20	19	24	42	52	M8	130	110	160	5
KSFT-25	24	28	52	62	M10	165	130	200	5
KSFT-30	24	28	52	62	M10	165	130	200	5
KSFT-40	24	30	52	72	M12	215	180	250	5
KSFT-50	24	30	52	72	M12	215	180	250	5
KSFT-60	35	42	72	112	M12	265	230	300	5
KSFT-80	35	42	72	112	M12	265	230	300	5

Type	Hopper dimensions							
	A1	B1	C1	D1	E1	F1	G1	I1
KSFT-20	300	210	70	10	10,5	63	25	10
KSFT-25	365	250	69	10	10	57,5	30	12
KSFT-30								
KSFT-40	420	260	130	15	15	115	40	14
KSFT-50								
KSFT-60	585	340	110	17,5	15,5	103	40	14
KSFT-80								

8.6. KSF PUMP

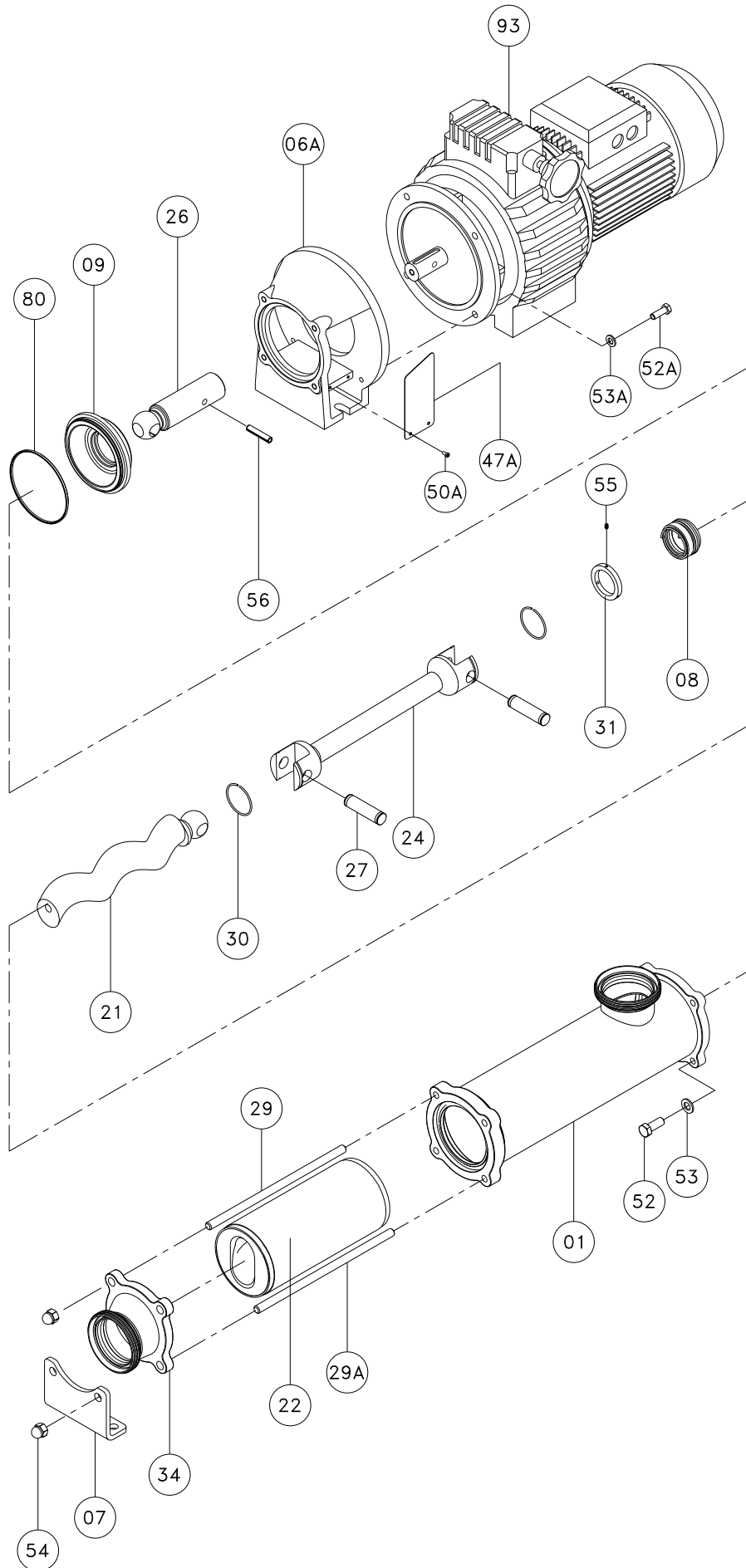

8.7. PARTS LIST KSF

Position	Description	Quantity	Material
01	Pump casing	1	AISI 316L
06A	Flange support	1	GG-25
07	Leg	1	AISI 304
08	Mechanical seal *	1	-
09	Seal cover	1	AISI 316L
21	Rotor	1	AISI 316L
22	Stator *	1	Black NBR
24	Connecting rod	1	AISI 316L
26	Shaft complement	1	AISI 316L
27	Bolt *	2	AISI 316L
29	Upper tie bar	2	AISI 304
29A	Lower tie bar	2	AISI 304
30	Safe ring	2	AISI 316L
31	Seal stop ring	1	AISI 316L
34	Discharge nozzle	1	AISI 316L
47A	Protection	2	Plastic
50A	Screw	4	A2
52	Hexagonal screw	4	A2
52A	Hexagonal screw	4	A2
53	Flat washer	4	A2
53A	Spring washer	4	A2
54	Blind nut	4	A2
55	Pin	3	A2
56	Pin	1	A2
80	O-ring *	1	NBR
93	Drive	1	-

(*) Recommended spare parts

8.8. DESPIECE BOMBA KSFT

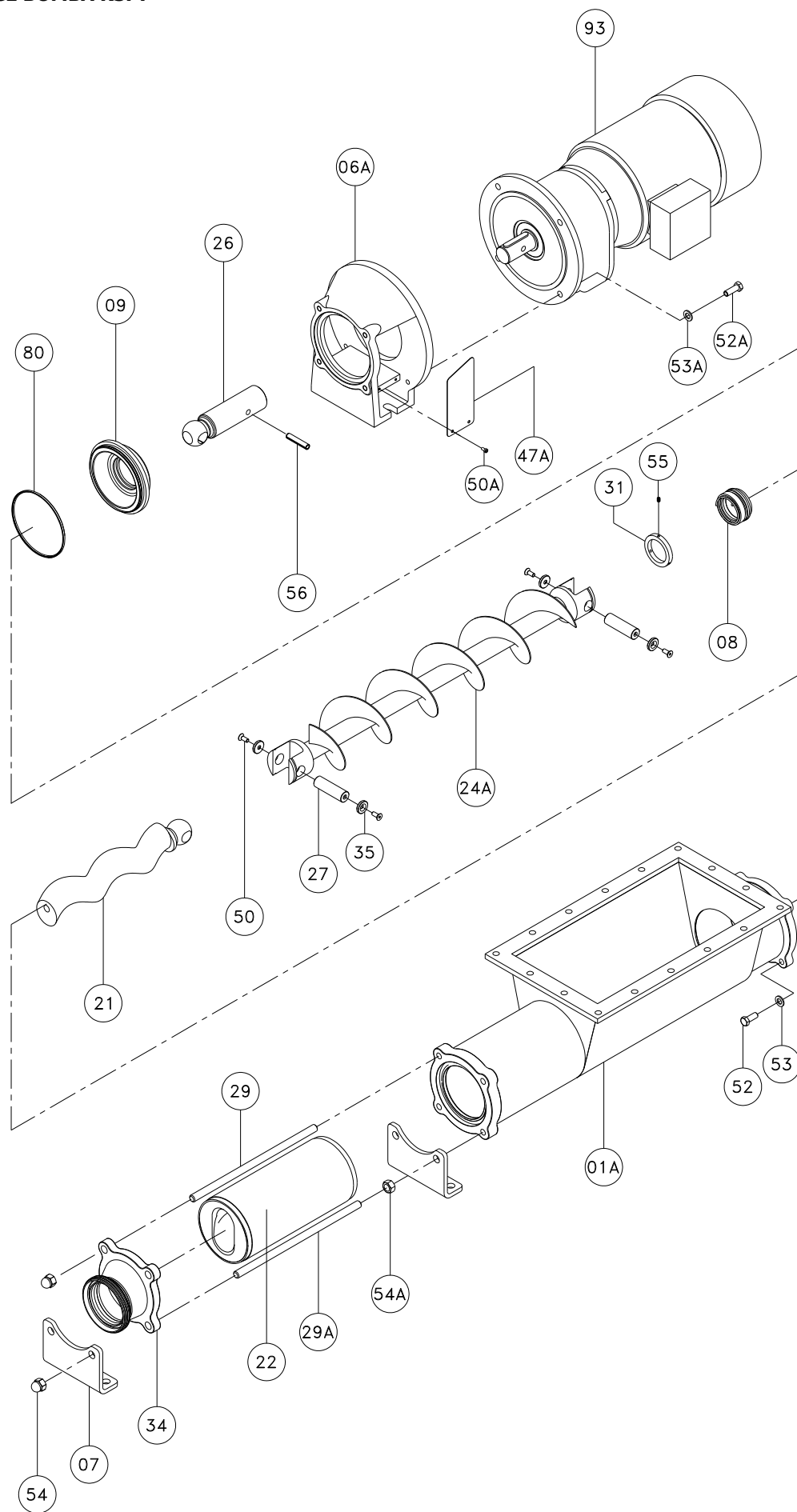

8.9. PARTS LIST KSFT

Position	Description	Quantity	Material
01A	Pump casing	1	AISI 316L
06A	Flange support	1	GG-25
07	Leg	2	AISI 304
08	Mechanical seal *	1	-
09	Seal cover	1	AISI 316L
21	Rotor	1	AISI 316L
22	Stator *	1	Black NBR
24A	Feeder screw	1	AISI 316L
26	Shaft complement	1	AISI 316L
27	Bolt *	2	AISI 316L
29	Upper tie bar	2	AISI 304
29A	Lower tie bar	2	AISI 304
31	Seal stop ring	1	AISI 316L
34	Discharge nozzle	1	AISI 316L
35	Bolt washer	4	AISI 316L
47A	Protection	2	Plastic
50	Countersunk screw	4	A2
50A	Screw	4	A2
52	Hexagonal screw	4	A2
52A	Hexagonal screw	4	A2
53	Flat washer	4	A2
53A	Spring washer	4	A2
54	Blind nut	4	A2
55	Pin	3	A2
56	Pin	1	A2
80	O-ring *	1	NBR
93	Drive	1	-

(*) Recommended spare parts

8.10. HEAVY DUTY TRANSMISSION

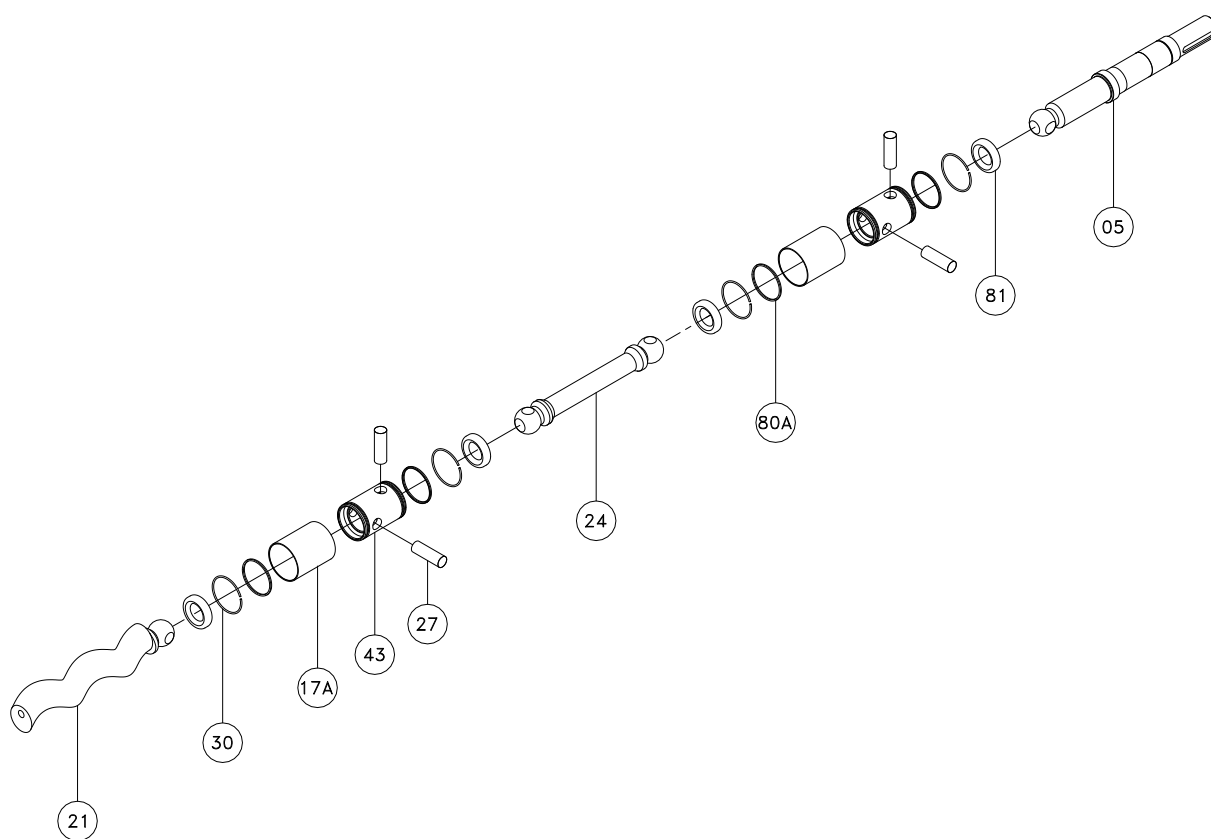

Position	Description	Quantity	Material
05	Pump shaft	1	AISI 316L
17A	Transmission shield bushing	2	AISI 316L
21	Rotor	1	AISI 316L
24	Connecting rod	1	AISI 316L
27	Bolt	4	AISI 316L
30	Safe ring	4	AISI 316L
43	Transmission bushing	2	AISI 316L
80A	O-ring	4	NBR
81	O-ring	4	NBR

(*) Recommended spare parts

8.11. COOLED MECHANICAL SEAL

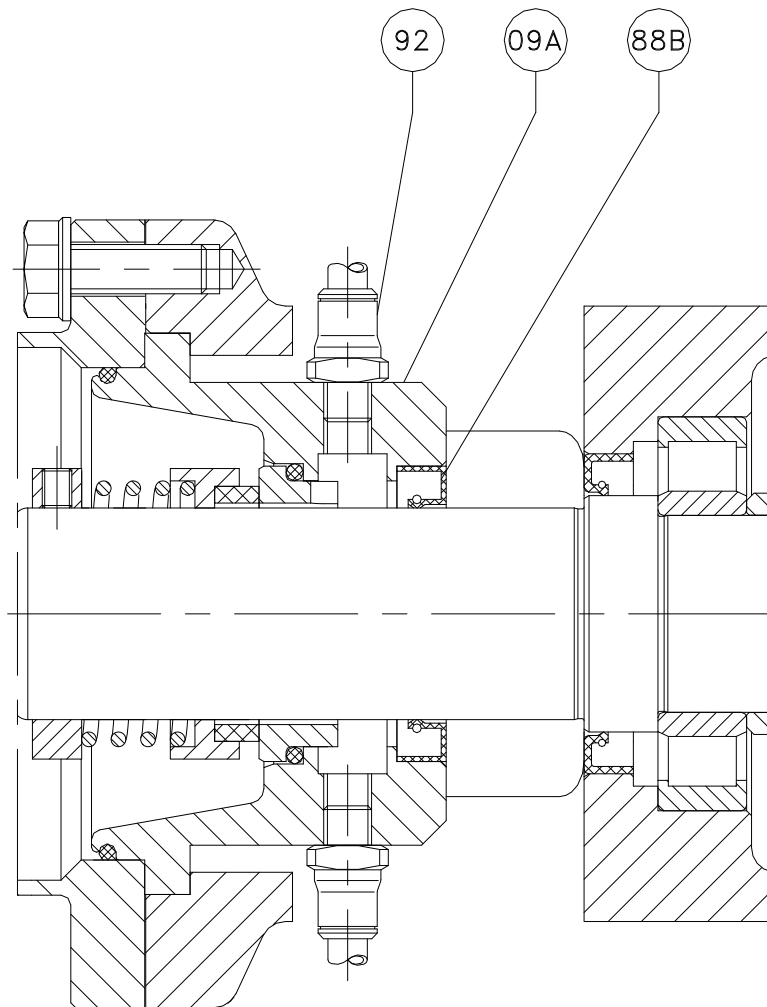

Position	Description	Quantity	Material
09A	Cooled seal cover	1	AISI 316L
88B	Lip seal *	1	NBR
92	Racord	2	AISI 316

(*) Recommended spare parts

8.12. DOUBLE MECHANICAL SEAL

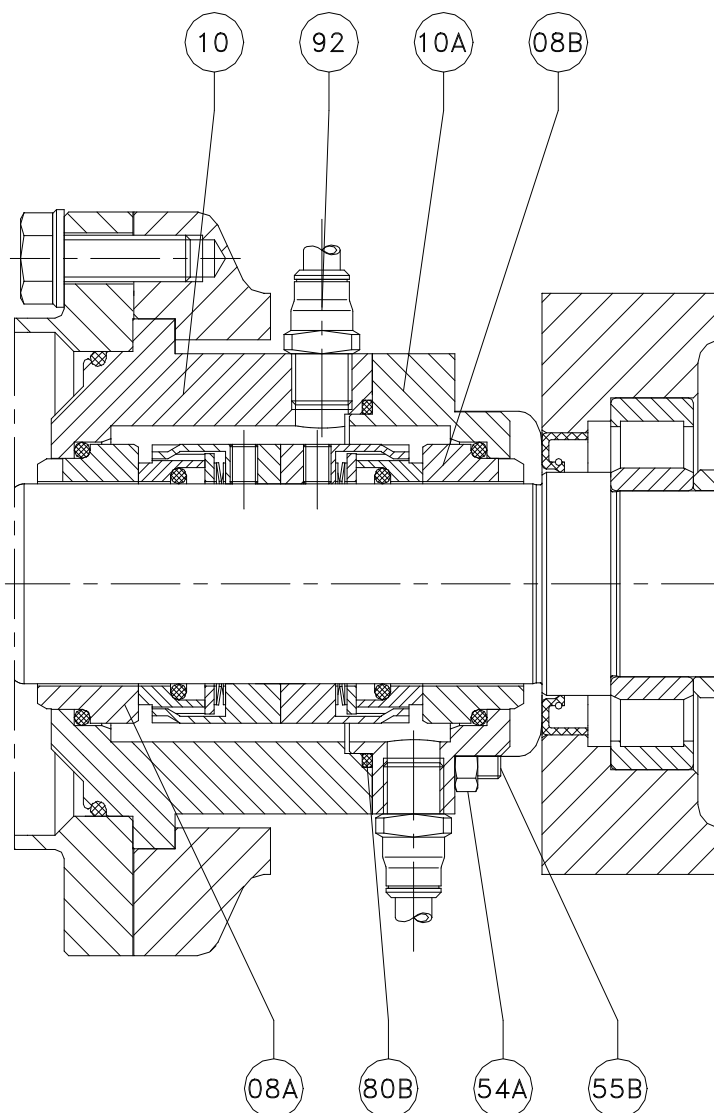

Position	Description	Quantity	Material
08A	Inside mechanical seal		-
08B	Outside mechanical seal *	1	-
10	Double seal cover	1	AISI 316L
10A	Double seal back cover	1	AISI 316L
54A	Hexagonal nut	2	A2
55B	Threaded rod	2	A2
80B	O-ring *	1	NBR
92	Racord BSPT	2	AISI 316

(*) Recommended spare parts

8.13. GLAND PACKING

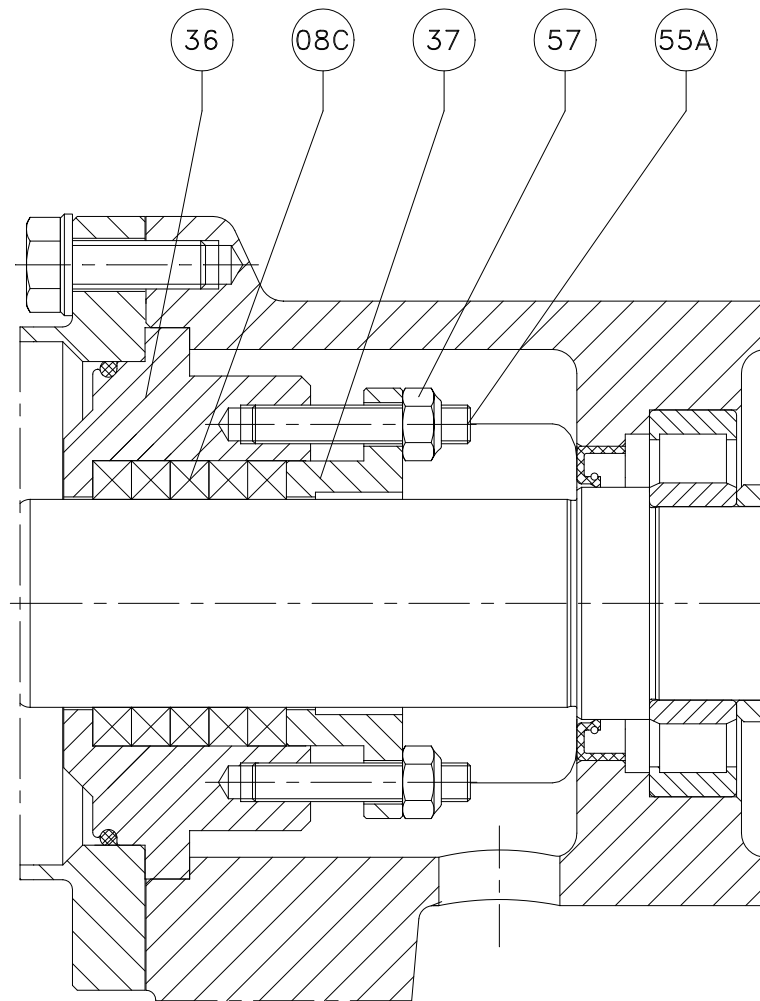

Position	Description	Quantity	Material
08C	Gland packing	5 rings	-
36	Packing box	1	AISI 316L
37	Gland	1	AISI 316L
55A	Pin	2	A2
57	Self-locking nut	2	A2

(*) Recommended spare parts

Насосы — Винтовые насосы Kiber KS, Kiber KSF

<http://k-tep.com.ua/>

✉ k-tep@ukr.net

■ МТС +38 066 9076563

■ Киевстар +38 098 3676414

Skype: [k-teppumps](#)

Замечания

Условия поставки: DDP склад г. Киев

Заметки

Время поставки рассчитано согласно дате предложения и изменяется в зависимости от даты подтверждения заказа.

Помещая заказ, Покупатель принимает предложение и все спецификации, характеристики и условия, указанные в данном документе.