

**ИНСТРУКЦИЯ ПО УСТАНОВКЕ И ТЕХНИЧЕСКОМУ  
ОБСЛУЖИВАНИЮ  
NTEA PUMP**

**INSTALLATION, SERVICE AND INSTRUCTIONS  
NTEA PUMP**



c/Telers, 54 Aptdo. 174  
E-17820 Banyoles  
Girona (Spain)



**Original Manual**  
01.621.30.00EN\_RevC  
ED. 2010/09



## EC DECLARATION OF CONFORMITY

(according to Directive 2006/42/EC, annex II, part A)

Manufacturer:

C/ Telers, 54  
17820 Banyoles (Girona) - SPAIN

Hereby declares, that the product:

HELICOIDAL IMPELLER PUMP

KIBER NTE / NTEA

Name

Type

conforms to the specifications of the Council Directive:

**Machine Directive** 2006/42/EC, and complies with the essential requirements of the Directive and Harmonised Standards:

UNE-EN ISO 12100-1/2:2004  
UNE-EN 809/AC:2001  
UNE-EN ISO 13857:2008  
UNE-EN 953:1997  
UNE-EN ISO 13732-1:2007

**Low Voltage Directive** 2006/95/CE (what repeal 73/23/EEC Directive), and are conforms with UNE-EN 60204-1:2006 and UNE-EN 60034-1:2004

**EMC Directive** 2004/108/CE (what repeal 89/336/CEE Directive), and are conforms with UNE-EN 60034-1:2004

In compliance with the Regulations **(CE) n° 1935/2004**, relating to materials and articles intended to come into contact with foodstuff (repeal Directive 89/109/EEC), the materials in contact with the product do not transfer their components in quantities which may jeopardise consumer's health or safety

Banyoles, 2012

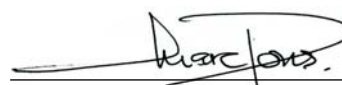
  
Marc Pons Bague Technical Manager

# 1. Safety

## 1.1. INSTRUCTIONS MANUAL

This manual contains information about the receipt, installation, operation, assembly, disassembly and maintenance of the Kiber NTE/NTEA pump.

The information published in the instruction manual is based on updated information.

INOXPA reserves the right to modify this instruction manual without prior notice.

## 1.2. START-UP INSTRUCTIONS

This Instructions Manual contains essential and useful information for properly operating and maintaining your pump.

Read these instructions carefully before starting up the pump; become familiar with the operation and use of your pump and follow the instructions closely. These instructions should be kept in a safe location near the installation.

## 1.3. SAFETY

### 1.3.1. Warning symbols



Danger for persons in general



Danger of injury caused by rotating equipment parts.



Electrical danger



Danger! Caustic or corrosive agents.



Danger! Suspended loads



Danger to the correct operation of the equipment.



Commitment to safety at the workplace.



Protective goggles requirement.

## 1.4. GENERAL SAFETY INSTRUCTIONS



Read this Instructions Manual carefully before installing the pump and starting it up. Contact INOXPA in case of doubt.

### 1.4.1. During installation



The *Technical Specifications* of Chapter 8 should always be observed.

Never start up the pump before it has been connected to the tubing.

Check that the motor specifications meet the requirements, especially when working under conditions that involve the risk of explosion.



During the installation, all the electric work should be carried out by authorised personnel.

### 1.4.2. During operation



The *Technical Specifications* of Chapter 8 should always be observed. Under no circumstances can the limit values specified be exceeded.

NEVER touch the pump or the tubes during operation when the pump is being used to decant hot fluids or when it is being cleaned.



The pump contains moving parts. Never place your fingers inside the pump while the pump is in operation.



**NEVER** operate the pump with the suction and delivery valves closed.

**NEVER** spray the electrical motor directly with water. The protection standard for the motor is IP-55: Protection against dust and sprayed water.

#### 1.4.3. During maintenance



The *Technical Specifications* of Chapter 8 should always be observed.

**NEVER** dismantle the pump before the tubes have been emptied. Remember that some of the fluid will always remain in the pump housing (when no drainage is provided). Note that the pumped fluid may be dangerous or very hot. Consult the regulations in effect in each country for these cases.

Do not leave parts loose on the floor.



**ALWAYS** disconnect the pump from the power supply before starting maintenance work. Remove the fuses and disconnect the cables from the motor terminals.

All electrical work should be carried out by authorised personnel.

#### 1.4.4. Compliance with the instructions

Any non-fulfilment of the instructions may result in a risk for the operators, the environment and the machine, and may result in the loss of your right to claim damages.

This non-fulfilment may result in the following risks:

- Failure of important functions of the machines/plant.
- Failure of specific maintenance and repair procedures.
- Possibility of electric, mechanical and chemical risks.
- Will place the environment in danger due to the release of substances.

#### 1.4.5. Guarantee

Any warranty provided shall immediately be cancelled and void *ipso jure*, and WINE PUMPS shall be compensated for any product liability claim from third parties, if:

- the service and maintenance work was not carried out in accordance with the service instructions, or the repair work has not been carried out by our personnel or it has been conducted without our written authorization;
- our equipment has been changed without prior written authorization;
- the parts or lubricants used are not original INOXPA parts and products;
- the materials were used incorrectly or negligently, or not in accordance with these instructions and their intended use;
- pump parts were damaged by excessive pressure owing to the lack of a safety valve.

The General Delivery Terms already provided also apply.



**No change can be made to the equipment without prior discussion with the manufacturer. For your safety, please use original spare parts and accessories. The use of other parts will exempt the manufacturer from any liability.**

**The service terms can only be changed with prior written authorisation from INOXPA.**

Please do not hesitate to contact us in case of doubts or if more complete explanations are required on specific data (adjustments, assembly, disassembly, etc.).

---

## 2. Table of Contents

<b>1. Safety</b>	
1.1. Instructions manual.....	3
1.2. Start-up instructions.....	3
1.3. Safety.....	3
1.4. General safety instructions.....	3
<b>2. Table of Contents</b>	
<b>3. General information</b>	
3.1. Description.....	6
3.2. Range of application.....	6
<b>4. Installation</b>	
4.1. Pump receipt.....	7
4.2. Transport and storage.....	7
4.3. Location.....	8
4.4. Tubes.....	8
4.5. Shut-off valves.....	8
4.6. Electrical installation.....	8
4.7. level sensor (OPTIONAL).....	9
<b>5. Start-up</b>	
5.1. Start-up.....	10
<b>6. Troubleshooting</b>	
<b>7. Maintenance</b>	
7.1. General information.....	12
7.2. Storage.....	12
7.3. Cleaning.....	12
7.4. Dismantling / assembly of the pump.....	13
<b>8. Technical Specifications</b>	
8.1. Technical Specifications.....	16
8.2. Weights.....	16
8.3. kiber NTE pump dimensions.....	17
8.4. kiber NTEA pump dimensions.....	17
8.5. kiber NTE pump.....	18
8.6. Kiber NTE pump parts list.....	19
8.7. Kiber NTEA pump.....	20
8.8. Kiber NTEA pump parts list.....	21

# 3. General information

## 3.1. DESCRIPTION

With a compact and robust design, INOXPA's Kiber NTE pumps form part of our range of positive-displacement pumps with helical rotor, intended for the wine industry.

NTEA version is supplied with a "bridge breaker" to provide a correct entry of the product to the feeder screw.

The hydraulic parts that form the pump are the rotor and the stator. The rotor is a round-section worm. The stator has two ribs and its pitch doubles that of the rotor, thus allowing empty cavities between the stator and the rotor. These cavities are used to transport the fluid. When the rotor turns within the stator, the cavities move longitudinally from the suction area to the discharge nozzle.

This type of pump is appropriate for pressures of up to 6 bars.

All pump parts in contact with the pumped product are made of stainless steel AISI 304L. The stator is made of PERBUNAN with a hardness particular to this application.

The most significant build details of this type of pump are as follows:

- Pump mounted on trolley
- Stainless steel hopper with drain
- Gearbox drive with conical gears
- Switchboard with stop/start, contactor, and emergency stop.
- Level sensor or product detector (optional)
- Frequency converter (optional)

This equipment is suitable for his use in food process.

## 3.2. RANGE OF APPLICATION

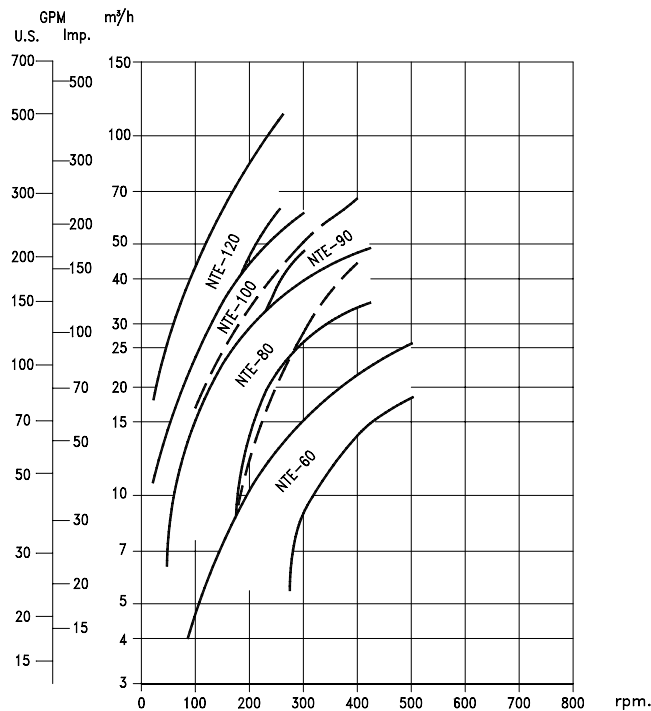

Each pump has performance limits. The pump was selected for certain pumping conditions at the time the order was placed. INOXPA shall not be liable for any damages resulting from the incompleteness of the information provided by the purchaser (nature of the fluid, RPM, etc.).

# 4. Installation

## 4.1. PUMP RECEIPT



**INOXPA cannot be held responsible for any damage to the equipment during transport or unpacking. Visually check that the packaging is not damaged.**

The pump will be accompanied by the following documents:

Dispatch notes.

Pump Instructions and Service Manual.

Motor Instructions and Service Manual (\*)

(\*) if the pump is supplied with a motor from INOXPA.

Unpack the pump and check the following:

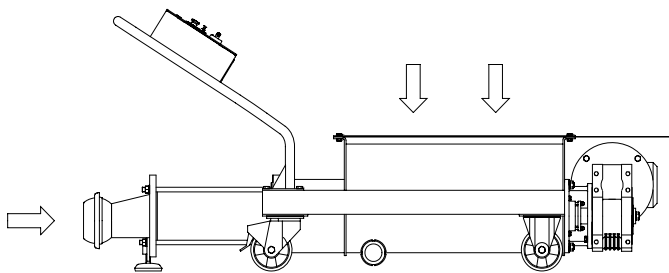

- The pump delivery connections and the inside of the hopper, removing the remains of any packaging materials.
- Check that the pump and the motor have not suffered any damage.
- If the equipment is not in good condition and/or any part is missing, the carrier should draw up a report accordingly as soon as possible.

### 4.1.1. Pump identification

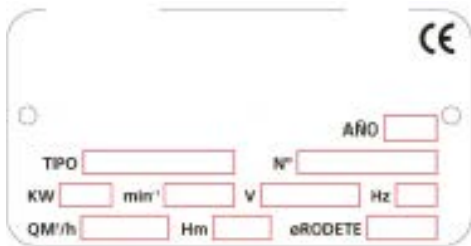

Serial number

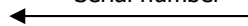

Pump plate

## 4.2. TRANSPORT AND STORAGE



**KIBER NTE/NTEA pumps are too heavy to be stored manually.**

Lift the pump as shown below:

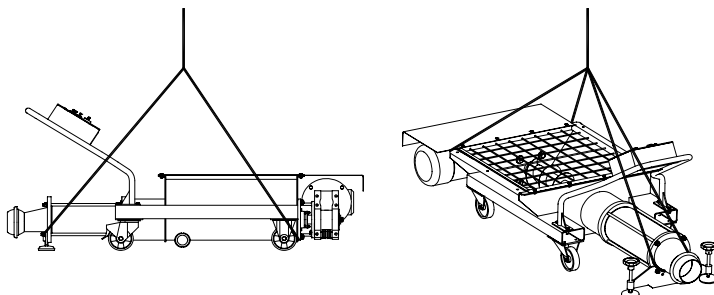

---

### 4.3. LOCATION

Place the pump as close as possible to the suction tank, and if possible below the fluid level.

Place the pump so as to allow sufficient space around it to access the pump and the motor. (See chapter 8. *Technical specifications* for dimensions and weights).

Set up the pump on a flat, level surface.



**Install the pump so as to allow sufficient ventilation.**

**If the pump is installed outdoors, it should be protected by a roof. Its location should enable easy access for any inspection or maintenance operations.**

### 4.4. TUBES

As a general rule, the suction and delivery tubes should be fitted in straight sections, with the least possible number of bends and accessories, in order to minimise head loss caused by friction.

Ensure that pump input and output fittings are properly aligned with the tubing and of a similar diameter to the pump connections.

Place the pump as close as possible to the suction tank, if possible below the fluid level, or even below the tank, to achieve the maximum static suction head.

Place tube supports as close as possible to the pump's suction inlet and delivery outlet.

### 4.5. SHUT-OFF VALVES

The pump can be isolated for maintenance purposes. To this end, shut-off valves should be fitted to the pump's suction and delivery connections.

These valves should ALWAYS be open when the pump is operating.

### 4.6. ELECTRICAL INSTALLATION



**The connection of the electrical motors must be performed by qualified personnel.**

**Take all necessary measures to prevent damage to connections and cables.**



**The electrical equipment, terminals and components of the control systems may still contain electric current when switched off. Contact with them may be dangerous for operators or cause irreversible damage to the equipment.**

**Before opening the pump, make sure that the electrical circuit is switched off.**

**Connect up the motor following the manufacturer's instructions.**

Electrical circuit diagram is supplied with a separate sheet.



#### 4.7. LEVEL SENSOR (OPTIONAL)

The level sensor of the NTE version has 3 detectors: one detects the maximum level, the other detects the minimum level and the third one detects the medium level. For a correct performance, the sensor must be assembled as indicated

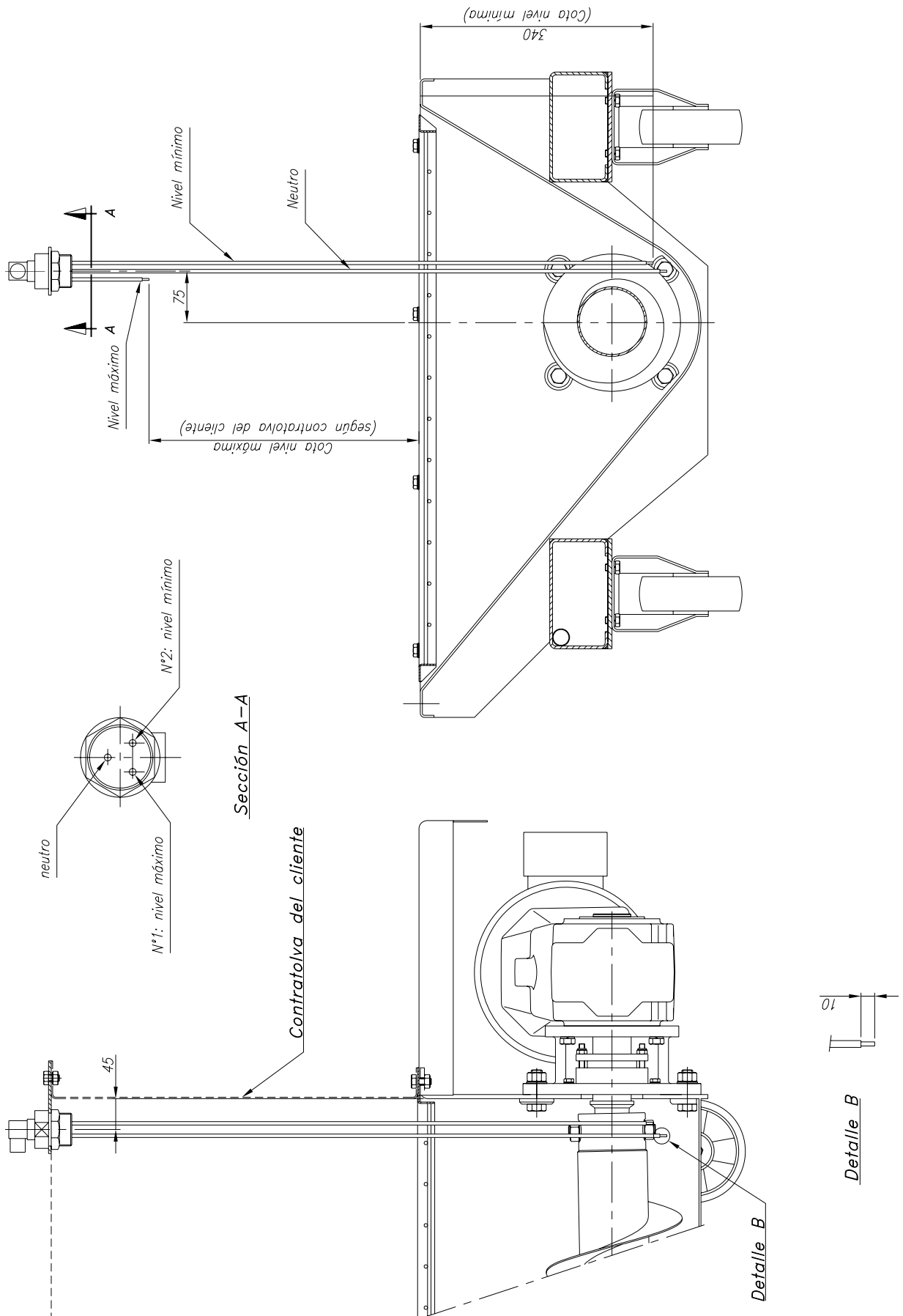

---

# 5. Start-up



Before starting the pump, carefully read the instructions provided in Chapter 4. *Installation*.

## 5.1. START-UP



Read Chapter 8. *Technical Specifications* carefully. INOXPA cannot be held liable for the incorrect use of the equipment.



**NEVER** touch the pump or the pipes when hot fluid is being pumped.

### 5.1.1. Checks before starting up the pump

- Fully open the shut-off valves on the suction and delivery pipes.
- If the fluid does not flow into the pump, prime the pump with fluid to be pumped.



The pump must **NEVER** be run dry.

- Check that the motor's direction of rotation is correct.

### 5.1.2. Checks when starting up the pump

- Check that the pump is not making any unusual noises.
- Check the flow pressure.
- Check that there are no leaks through the sealed areas.



A shut-off valve on the suction pipe must not be used to regulate flow. Shut-off valves must be fully open during operation.



Check the motor's power consumption to avoid electric overload.

### 5.1.3. Danger signs in the hopper

The hopper must show caution signs to symbolise the danger of removing any residue inside the hopper. These signs must be situated where the operators handling these residues can see them.

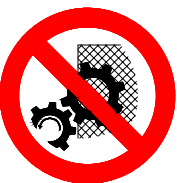

Do not remove protective elements.



Risk of injury in dangerous areas.

## 6. Troubleshooting

The following table provides solutions to problems that might arise during pump operation. The pump is assumed to have been properly installed and correctly selected for the application.

Please contact INOXPA if you require technical assistance.

Operating problems	Probable causes
Motor overload	3, 7, 8, 9.
The pump does not provide enough flow or pressure	4, 5, 7, 8.
No pressure on the delivery side	1, 2.
Uneven delivery flow / pressure	3, 8.
Noise and vibration	3, 4, 7, 8, 9, 10.
The pump gets clogged	7, 8, 9, 10.
Overheated pump	3, 7, 8, 9.
Abnormal wear	4, 9, 10.
Leaking through the packing material.	6.

Probable causes	Solutions
1 Wrong direction of rotation	Reverse the motor rotation direction.
2 Lack of product.	Fill the hopper.
3 Pump speed too high	Reduce the pump speed.
4 Stator worn out or running dry.	Replace the stator
5 Pump speed too low	Increase the pump speed.
6 Damaged or worn packing material.	Replace packing material.
7 Delivery pressure too high	If necessary, reduce load losses, e.g. by increasing the diameter of the delivery tube.
8 Fluid viscosity too high	Reduce the pump speed.
9 Taught tubes	Connect the tubing to the pump avoiding taughtness.
10 Foreign particles in the fluid	Reverse the pump rotation direction and remove foreign particles.



**If the problems persist, stop using the pump immediately. Contact the pump manufacturer or their representative.**

# 7. Maintenance

## 7.1. GENERAL INFORMATION

Like any other machine, this pump requires maintenance. The instructions contained in this manual cover the identification and replacement of spare parts. The instructions have been prepared for maintenance personnel and for those responsible for the supply of spare parts.



Please read Chapter 8. *Technical Specifications* carefully.

All replaced material should be duly eliminated/recycled according to the directives in effect in the area.



ALWAYS disconnect the pump from the power supply before undertaking maintenance work.

### 7.1.1. Check packing material

Regularly check that there are no leaks in the shaft area. If there are leaks through the packing material, replace it following the instructions given under the Assembly and Dismantling section.

## 7.2. STORAGE

The pump must be completely emptied of fluid before storage. If possible, avoid exposing the components of the pump to excessively damp environments.

## 7.3. CLEANING

### Manual cleaning



The use of aggressive cleaning products such as caustic soda and nitric acid may give rise to skin burns.

Use rubber gloves during the cleaning process.



Always use protective goggles.

### 7.3.1. Automatic CIP (cleaning-in-place)

If the pump is installed in a system fitted with a CIP process, there will be no need for stripping.

The recommended minimum liquid speed for an effective process of cleaning is 1,8 m/s (minimum  $Re > 100\,000$  at 1,0~2,5 bar). If it is not fitted with an automatic cleaning process, strip the pump pursuant to the instructions given in the section entitled Stripping and Assembly of the pump.

#### Cleaning solutions for CIP processes.

Only use clear water (chloride free) to mix with the cleaning agents:

**a) Alkaline solution:** 1% in weight of caustic soda (NaOH) to 70°C (150°F)

1 Kg NaOH + 100 l. water = cleaning solution

or

2.2 l. NaOH at 33% + 100 l. of water = cleaning solution

**b) Acid solution:** 0.5% in weight of nitric acid (HNO<sub>3</sub>) to 70°C (150°F)

0.7 litres HNO<sub>3</sub> to 53% + 100 l. water = cleaning solution



Monitor the concentration of cleaning solutions, it could give rise to the deterioration of the pump sealing gaskets.

In order to remove any remains of cleaning products, ALWAYS rinse the element in question with clean water after completing the cleaning process.

### 7.3.2. Automatic SIP (sterilization-in-place)

The process of sterilization with steam is applied to all the equipment including the pump.



**Do NOT start the pump during the process of sterilization with steam.**

**The parts/materials suffer no damage if the indications specified in this manual are observed.**

**No cold liquid can enter the pump till the temperature of the pump is lower than 60°C (140°F).**

**A flow by-pass is recommended to be used in order to assure the flow of sterile product after the pump.**

#### **Maximum conditions during the SIP process with steam or overheated water**

a)	<b>Max. temperature:</b>	140°C / 284°F
b)	<b>Max. time:</b>	30 min
c)	<b>Cooling:</b>	Sterile air or inert gas
d)	<b>Materials:</b>	EPDM / PTFE (recommended) FPM / NBR (not recommended)

## 7.4. DISMANTLING / ASSEMBLY OF THE PUMP

### 7.4.1. Stator, rotor and connecting rod

#### ⇐ Disassembly

Loosen the nuts (54) and remove the washers (53). Remove the leg (07, from NTE-80 to NTE-120) and the discharge nozzle (34). Remove the stator (22), if necessary secure the rotor (21) by holding the connecting rod (24A). For sizes NT-80/90, remove the stator ring (30) and the O-ring (80). Remove the protection grid (46) from the hopper. Remove the screws (52B) and washers (35B) from the bolt (27) on the drive side. Remove the bolt (27), if necessary use an extractor with the bolt holes. Remove the connecting rod (24A) with the rotor (21). For NTE-60 move forward and remove it from the hopper in the body. Remove the bolt (27) from the rotor (21) as indicated above.

#### ⇒ Assembly

Connect the rotor (21) to the connecting rod (24A) using the bolt (27) and secure in place with the screws (52B) and washers (35B). Mount the assembly at the front of the hopper (for NTE-60, insert it into the hopper). Connect the connecting rod (24A) to the shaft (05) using the bolt (27) and secure in place with the screws (52B) and washers (35B). For sizes NT-80/90, place the stator ring (30) and the O-ring (80) in front of the casing. Insert the stator (22), if necessary secure the rotor (21) by holding the connecting rod (24A). Mount the discharge nozzle (34) and the leg (07, from NTE-80 to NTE-120). Place the nuts (54A) and washers (53).

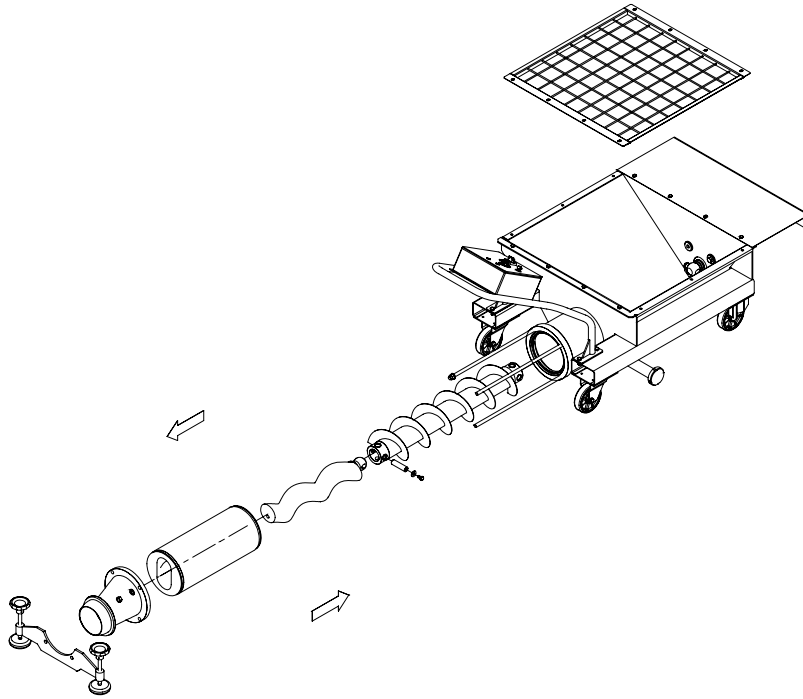

#### 7.4.2. Drive shaft and packing material

##### ⇒ Disassembly

Remove the drive protection (47). Remove the screws (52A) and washers (35, 35A by loosening the nuts (54) and disassembling the lantern (04), shaft (05), and drive (93) assembly. Remove the screw (52F) and the washer (35C) from the back part of the drive. Remove the screws (52C) and washers (53C) that are fixing the packing box (36). Remove the packing from the packing box (36) and the shaft (05) from the front. Once the packing has been removed, remove the gland (37) by loosening the nuts (57). Proceed to replace the gland packing rings (08G).

##### ⇐ Assembly

Before introducing the new gland packing, check the condition of the surface of the shaft (05) and its packing box (36). The shaft should have a polished surface finishing. Cut the rings to the required length with a 45° angle, as shown in Figure 7.1. Check that the cuts match the shaft. Gently open the rings (Figure 7.2) to allow the passage of the shaft, and place each of the term in turn. First insert the junction and then push the rings to the end.

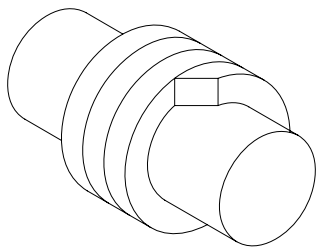
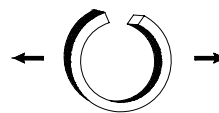

Figure 7.1



First open radially and then axially.

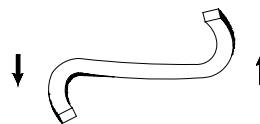
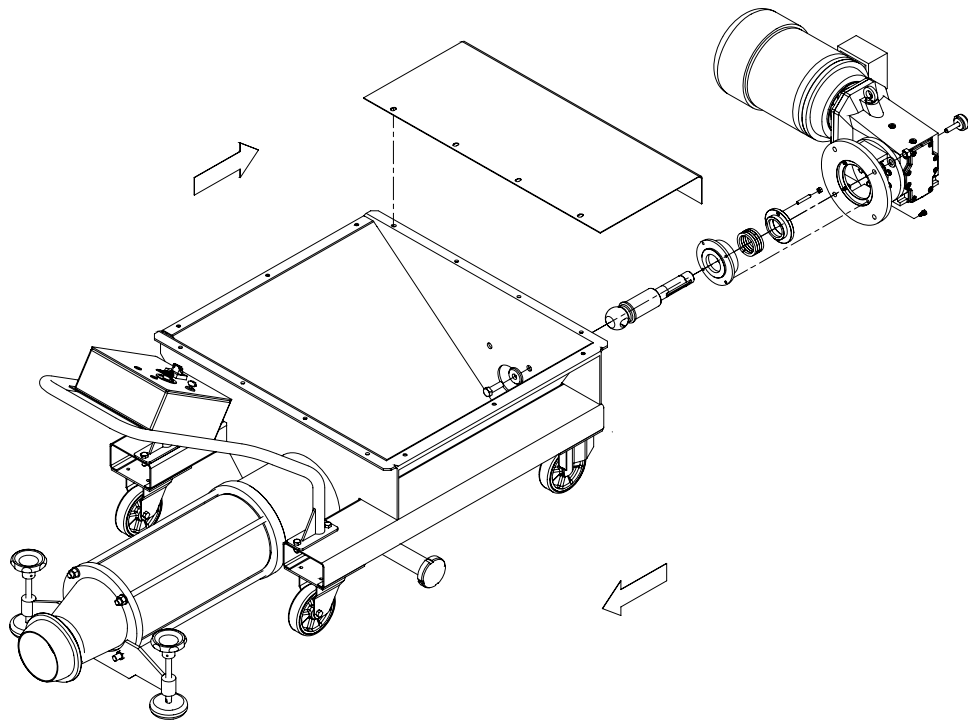

Figure 7.2

The rings (08G) must be in contact with each other, and the cuts of each ring must be arranged against each other forming a 120° angle. Turn the shaft (55) from time to time to facilitate the settlement of each ring. Insert the gland (37) and place the nuts (57). Fasten the nuts (57) manually and evenly, and make sure that the shaft rotates freely. Assemble the packing of the packing box (36) and the shaft (05) inside the lantern (04). Fix the screws (52C) with the washers (53C) and the shaft (05) at the back of the drive (93) with the screw (52F) and washer (35C).

Let the pump operate with constant leaks for about 10 minutes, then fasten the gland (37) using the nuts (57) until the leaks are reduced to an acceptable level (15 to 20 drops/minute). A dripping leak is essential for the normal operation of the gland packing in order to avoid the overheating of the screws.

When the packing has become fully compressed after successive adjustments, replace the full contents of the box (never replace the packing only partially). Always use good-quality packing.



### 7.4.3. Change of drive



#### **Disassembly.**

Loosen the screws (52E) and the washers (53E). Remove the screw (52F) and the washer (35C) and pull out the drive (93).



#### **Assembly.**

Insert the hollow drive shaft (93) into the drive shaft (05) and secure it with screws (52E) and washers (53E). Then secure this assembly with the screw (52F) and washer (35C).

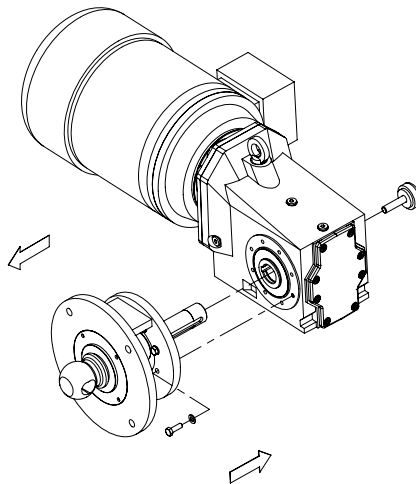

# 8. Technical Specifications

## 8.1. TECHNICAL SPECIFICATIONS

Maximum working pressure .....	6 bar (87 PSI)
Maximum temperature .....	85°C (NBR) 185 °F (NBR)
Noise level .....	60-80 dB(A)
Delivery connections .....	Spherical adapter (standard)



Use special protection when the noise level in the operation area exceeds 85 dB(A).

Pump type	Power (kW)	Speed (rpm)	Output (m <sup>3</sup> /h)	Minimum starting torque (Nm)
NTE-60	3	210	8 – 11	110
NTE-80	5.5	210	20 - 25	150
NTE-90	7.5	210	25 - 35	190
NTE-100	7.5	210	40 - 50	245
NTE-120	15	170	55-70	270

(1) Nominal flow for de-stemmed grapes at 2 - 4 bar.

Pump type	Power (kW)	Speed (r.p.m.)	Output (2) (m <sup>3</sup> /h)	Minimum starting torque (Nm)	Feed	
					Power (kW)	Speed (r.p.m.)
NTEA-80	5,5	185	10 – 18	150	1,5	60
NTEA-100	7,5	169	20 - 38	245	1,5	60

(2) Nominal flow for fermented grapes at 2 - 4 bar.

### Materials

Parts in contact with the product .....	AISI 304L
Stator .....	NBR
Other materials for optional stators .....	Check with the supplier
Surface finish .....	Sand blasted

### Packing material

Packing material .....	Teflon-reinforced aramid fibre
------------------------	--------------------------------

## 8.2. WEIGHTS

Pump type	Weight [Kg]	Weight [lbs]
NTE-60	190	420
NTE-80	295	650
NTE-90	320	705
NTE-100	345	760
NTE-120	570	1260
NTEA-80	365	805
NTEA-100	415	915



### 8.3. KIBER NTE PUMP DIMENSIONS

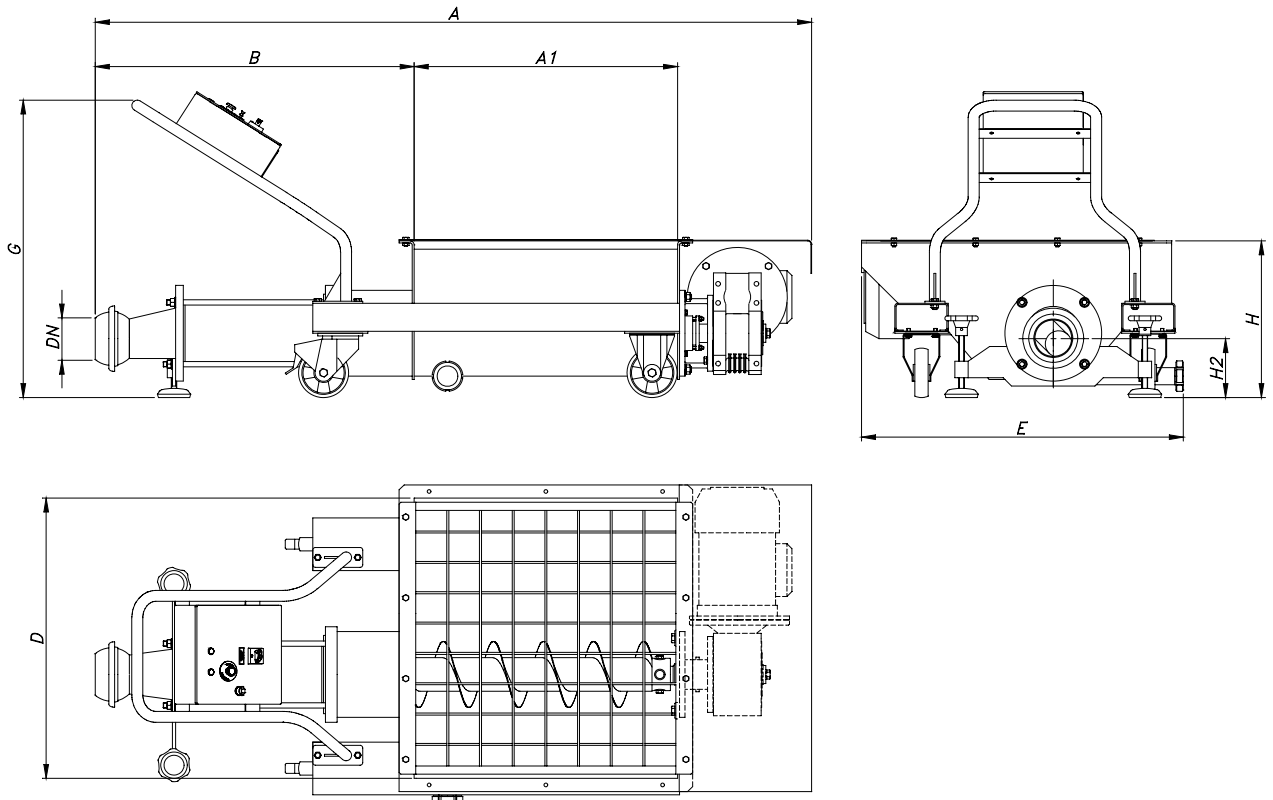

PUMP TYPE	DN	A	A1	B	D	E	G	H	H2
NTE-60	100	1720	700	670	750	835	900	405	148
NTE-80	120	2150	790	955	850	950	950	475	180
NTE-90		2210		1015					170
NTE-100	150	2255	850	1060	1000	1100	950	490	165
NTE-120		2490		1185					163

### 8.4. KIBER NTEA PUMP DIMENSIONS

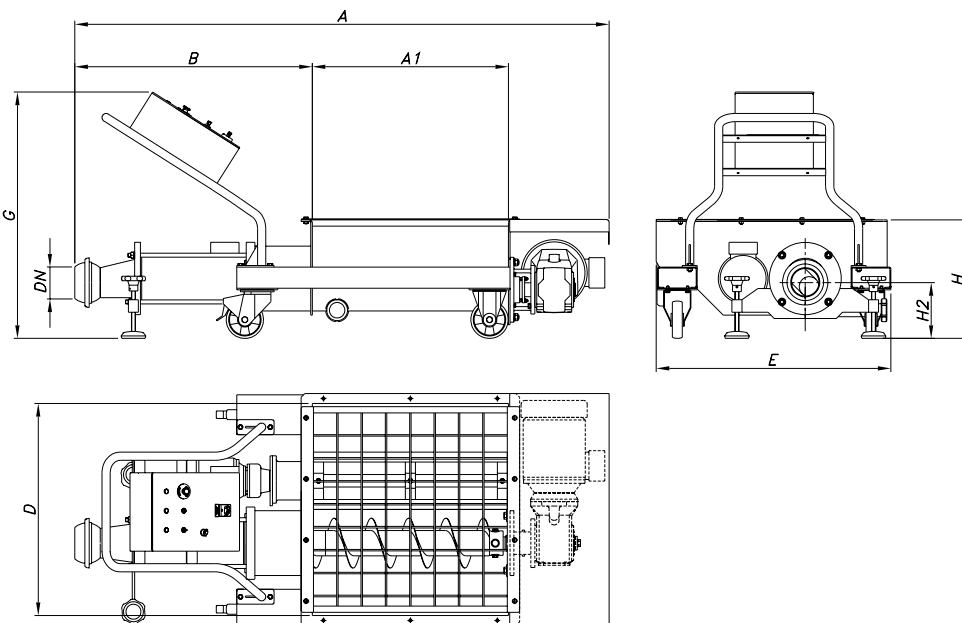

PUMP TYPE	DN	A	A1	B	D	E	G	H	H2
NTEA-80	120	2150	790	955	850	950	1000	475	225
NTEA-100	150	2255		1060					210

8.5. KIBER NTE PUMP

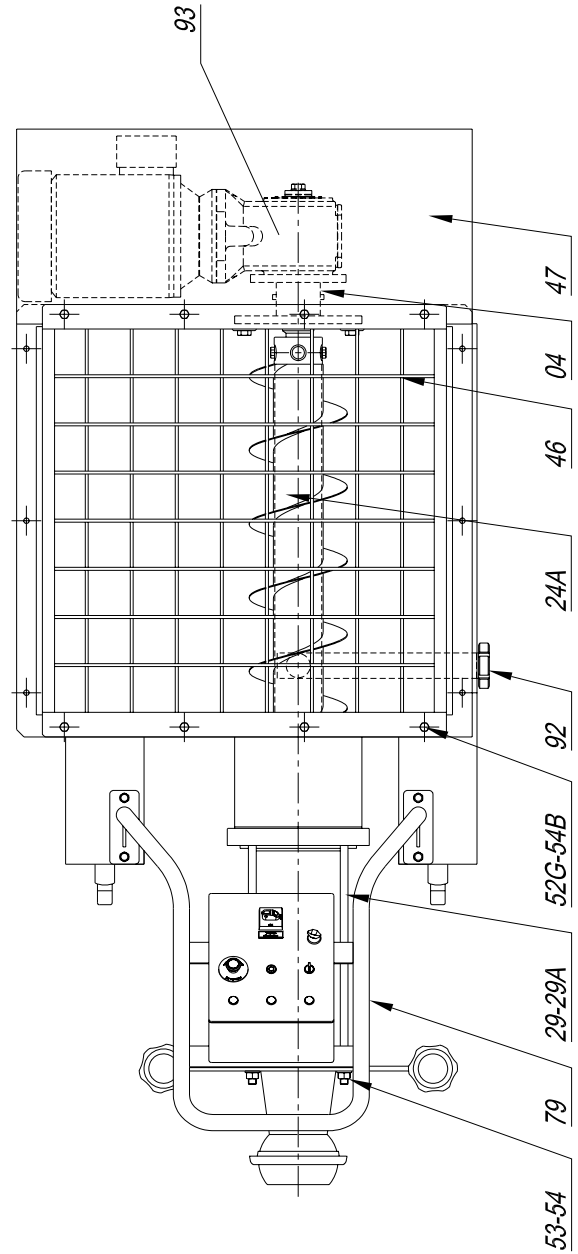
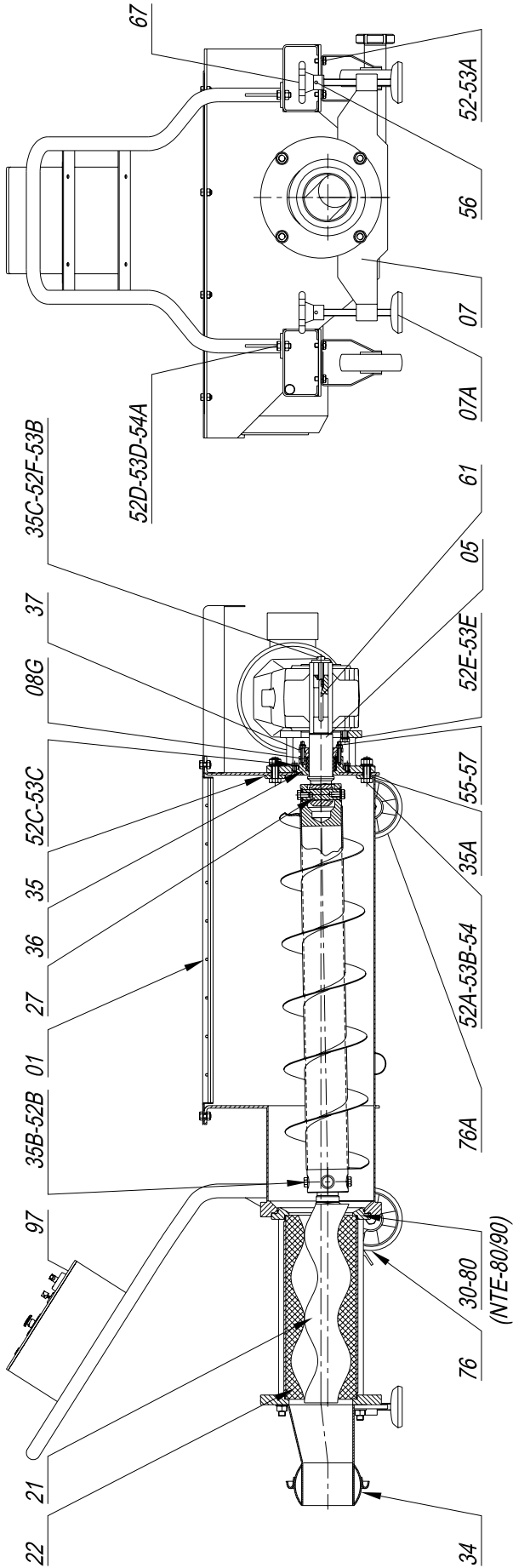

## 8.6. KIBER NTE PUMP PARTS LIST

Position	Description	NTE-60	NTE-80/90	NTE-100	NTE-120	Material
01	Hopper casing			1		AISI 304
04	Lantern			1		F-1
05	Drive shaft			1		AISI 329
07	Brake support plate	-		1		F-1
07A	Non-vibratory foot	-		2		-
08G	Packing material *			4		Teflon-reinforced
21	Rotor			1		AISI 304
22	Stator *			1		Perbunan
24A	Connecting rod			1		AISI 304
27	Bolt *			2		AISI 329
29	Upper tie bar			2		AISI 304
29A	Lower tie bar			2		AISI 304
30	Stator ring	-	1		-	AISI 304
34	Discharge nozzle			1		AISI 304
35	Lantern-fixing washer			2		AISI 304
35A	Lantern-fixing washer			2		AISI 304
35B	Bolt washer			4		AISI 304
35C	Shaft-fixing washer			1		AISI 304
36	Packing box			1		AISI 304
37	Gland			1		AISI 304
46	Protective grid			1		AISI 304
47	Drive protection			1		AISI 304
52	Hexagonal screw			16		A2
52A	Hexagonal screw			4		A2
52B	Hexagonal screw			4		A2
52C	Hexagonal screw			4		A2
52D	Hexagonal screw			4		A2
52E	Hexagonal screw			8		A2
52F	Hexagonal screw			1		A2
52G	Hexagonal screw			8		A2
53	Flat washer			4		A2
53A	Grower washer			16		A2
53B	Grower washer			5		A2
53C	Grower washer			4		A2
53D	Grower washer			4		A2
53E	Grower washer			8		A2
54	Hexagonal nut			8		A2
54A	Hexagonal nut			4		A2
54B	Hexagonal nut			8		A2
55	Pin			2		A2
56	Flexible pin	-		2		F-143
57	Self-locking nut			2		A2
61	Key			1		F-114
67	Brake wheel	-		2		Plastic
76	Rotary wheel			2		Polyurethane
76A	Fixed wheel			2		Polyurethane
79	Trolley handle			1		F-1
80	O-ring *	-	1		-	NBR
92	Cap nut			1		Plastic
93	Gearbox drive			1		-
97	Electrical controls			1		-

(\*) Recommended spare parts

8.7. KIBER NTEA PUMP

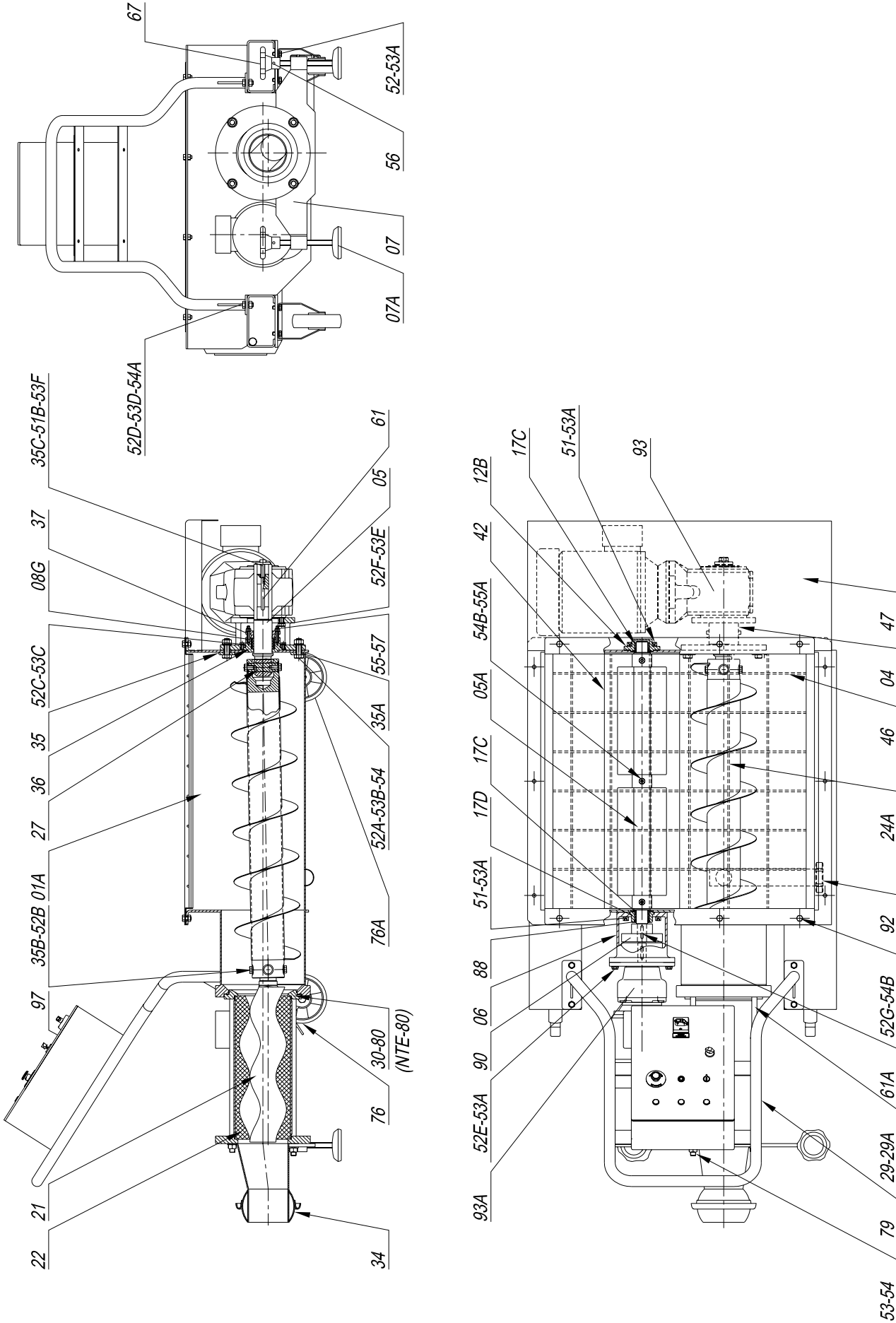

## 8.8. KIBER NTEA PUMP PARTS LIST

Position	Description	NTEA-80	NTEA-100	Material
01A	Hopper casing		1	AISI 304
04	Lantern		1	F-1
05	Drive shaft		1	AISI 329
05A	Blade shaft		1	AISI 304
06	Gear support		1	GG-15
07	Brake support plate		-	F-1
07A	Non-vibratory foot		-	-
08G	Packing material *		4	Teflon-reinforced
12B	Bushing cover		1	AISI 304
17C	Friction bearing		2	PTFE
17D	Guide bushing		1	AISI 304
21	Rotor		1	AISI 304
22	Stator *		1	Perbunan
24A	Connecting rod		1	AISI 304
27	Bolt *		2	AISI 329
29	Upper tie bar		2	AISI 304
29A	Lower tie bar		2	AISI 304
30	Stator ring	1	-	AISI 304
34	Discharge nozzle		1	AISI 304
35	Lantern-fixing washer		2	AISI 304
35A	Lantern-fixing washer		2	AISI 304
35B	Bolt washer		4	AISI 304
35C	Shaft-fixing washer		1	AISI 304
36	Packing box		1	AISI 304
37	Gland		1	AISI 304
42	Blade		1	AISI 304
46	Protective grid		1	AISI 304
47	Drive protection		1	AISI 304
51	Hexagonal screw		6	A2
51B	Hexagonal screw		1	8.8
52	Hexagonal screw		16	A2
52A	Hexagonal screw		4	A2
52B	Hexagonal screw		4	A2
52C	Hexagonal screw		4	A2
52D	Hexagonal screw		4	A2
52E	Hexagonal screw		8	A2
52F	Hexagonal screw		1	A2
52G	Hexagonal screw		8	A2
53	Flat washer		4	A2
53A	Grower washer		16	A2
53B	Grower washer		5	A2
53C	Grower washer		4	A2
53D	Grower washer		4	A2
53E	Grower washer		8	A2
54	Hexagonal nut		8	A2
54A	Hexagonal nut		4	A2
54B	Hexagonal nut		8	A2
55	Pin		2	A2
55A	Stud		3	A2
56	Flexible pin		-	F-143
57	Self-locking nut		2	A2
61	Key		1	F-114
61A	Key		1	F-114
67	Brake wheel		-	Plastic
76	Rotary wheel		2	Polyurethane

76A	Fixed wheel		2	Polyurethane
79	Trolley handle		1	F-1
80	O-ring *	1	-	NBR
88	Lip seal		1	NBR
90	Coupling		1	-
92	Cap nut		1	Plastic
93	Gearbox drive		1	-
97	Electrical controls		1	-

(\*) Recommended spare parts

<http://k-tep.com.ua/>

✉ [k-tep@ukr.net](mailto:k-tep@ukr.net)

■ Office +38 044 2091823

■ МТС +38 066 9076563

■ Киевстар +38 098 3676414

Skype: [k-teppumps](#)

## Замечания

*Условия поставки: DDP склад г. Киев*

### Заметки

Время поставки рассчитано согласно дате предложения и изменяется в зависимости от даты подтверждения заказа.

Размещая заказ, покупатель принимает предложение и все спецификации, характеристики и условия, указанные в данном документе.