

**ИНСТРУКЦИЯ ПО УСТАНОВКЕ И
ТЕХНИЧЕСКОМУ ОБСЛУЖИВАНИЮ**

Steriping — Система безразборной очистки

**INSTALLATION, SERVICE AND
MAINTENANCE INSTRUCTIONS**

STERIPIG FLUID RECOVERY SYSTEM



c/Telers, 54 Aptdo. 174
E-17820 Banyoles
Girona (Spain)



EC DECLARATION OF CONFORMITY (according to Directive 2006/42/CE, annex II, part A)

Manufacturer:

C/ Telers, 54
17820 Banyoles (Girona) - SPAIN

Hereby declares, that the product:

FLUID RECOVERY SYSTEM

Name

STERIPIG – 1 ball

Type

conforms to the specifications of the Council Directive:

Machine Directive 2006/42/CE, and complies with the essential requirements of the Directive and Harmonised Standards:

UNE-EN ISO 12100-1/2:2004
UNE-EN 953:1997
UNE-EN ISO 13732-1:2007

Pressure Equipment Directive 97/23/CE, the equipment has been designed and manufactured in accordance with the requirements of the Directive.

Max operating P.: DN-40/1 1/2" to DN-80/3" = 10 bar

Diameter: DN-25 < X < ó = DN-100

Equipment category: Category I, determined according Article 3 Section 1.3.a, first paragraph Annex II, Table 6

This material SHALL carry CE marking.

Conformity Assessment Module: Module A

In compliance with the Regulations (CE) n° 1935/2004, relating to materials and articles intended to come into contact with foodstuff (repeal Directive 89/109/CEE), the materials in contact with the product do not transfer their components in quantities which may jeopardise consumer's health or safety.

Declaration of Incorporation (Directive 2006/42/CE, annex II, part B):

The equipments above mentioned won't put to operation till the machine into or onto it will be installed must comply with the stipulations of the Machine Directive.

Banyoles, 2012

Marc Pons Bague Technical Manager

1. Safety

1.1. INSTRUCTION MANUAL

This instruction manual contains basic recommendations which should be met during the installation, start-up and operation of the plant.

The information published in the instruction manual is based on current data. INOXPA reserves the right to modify this instruction manual without prior notice.

1.2. INSTRUCTIONS FOR START-UP

This instruction manual contains important information on operating and maintaining the equipment.

Not only should the safety instructions indicated in this chapter be observed and fulfilled, but so should the special measures and recommendations included in the other chapters of this manual. These instructions should be kept in a safe location near the installation.

1.3. SAFETY

1.3.1. Warning symbols



Danger for persons in general



Danger of injury caused by rotating equipment parts.



Electrical danger



Danger! Caustic or corrosive agents.



Danger! Suspended loads



Danger to the correct operation of the equipment.



Commitment to safety at the workplace.



Protective goggles requirement.



Strong magnetic field.

1.4. GENERAL SAFETY INSTRUCTIONS



Read the instruction manual carefully before installing and starting up the equipment. Contact INOXPA in case of doubt.

This equipment is suitable for processing of food products and/or pharmaceutical products.

Do not use in processes with products and/or temperatures that are not compatible with the sealing materials and/or the PIG. It is the responsibility of the system designer to determine this compatibility.

The equipment must only be handled by qualified staff.

The compatibility of the electrical equipment is the responsibility of the designer of the system or the person who determines its specifications.

1.4.1. During the installation



The Technical Specifications of Chapter 8 should always be observed.

The installation and use of the equipment should always be carried out in accordance with applicable regulations regarding health and safety.

Do not use the equipment until you have checked that it is functioning correctly. Once it has been assembled, repaired, cleaned or modified connect the air and the electrical supplies and check that the unit operates correctly with no leaks.



Fully tighten all the components prevent them from becoming loose. If the equipment operates at high frequency or is installed where there is substantial vibration, ensure that all the parts are securely fastened.

Provide for possible pressure drops in the pneumatic circuit and/or faults in the electrical supply. This may lead to safety problems in the installation.

Provide for emergency shutdowns.

Check the operation of the equipment when restarting after an emergency or unexpected shutdown.



The PIG and the discs inside the actuating carriage are magnetised. DO NOT place close to metal components as they have a strong magnetic attraction. DO NOT leave the components on metal tables or benches during handling. DO NOT place close to metal tools and/or objects that can be attracted by the magnetic field.

When handling the magnetic discs, DO NOT place any part of your body between a disc and a metal component, and/or another disc, as they have a very strong magnetic pull. Establish the safety measures required to be able to handle these items without risk.



The working lifetime of the PIG greatly depends on the quality of the installation including the interior finishing of pipes, welds, cleanliness, and any deformity that may affect the smooth movement of the PIG.

The equipment must be installed and used in accordance with the normal good practices of the industry, and only by qualified staff.



During the installation, all the electric work should be carried out by authorised personnel.

1.4.2. During operation

NEVER EXCEED the specified threshold values.



Do not use in atmospheres where there are corrosive gases as this might damage the actuator and the seals.

Do not use in atmospheres with strong magnetic fields as this may adversely affect the PIG detectors.



The working lifetime of the PIG greatly depends on the quality of the installation including the interior finishing of pipes, welds, cleanliness, and any deformity that may affect the smooth movement of the PIG.

The equipment must be used in accordance with the normal good practices of the industry and by qualified staff.



NEVER touch the equipment and/or pipes that are in contact with the liquid during operation. If working with hot fluids, there is a risk of burns.

The PIG travels through the tubes at high speeds so the circuit must be designed to be safe and never allow the PIG to be ejected during operation.

Do not touch the actuator when the installation is in operation and/or under compressed-air pressure.

The degree of water-protection of the PIG detectors and the actuator detector is IP 67 (completely protected from dust and immersion in water).

1.4.3. During maintenance



The *Technical Specifications* of Chapter 8 should always be observed.

NEVER disassemble the equipment until the pipes have been drained and are not pressurised, and the actuator air supply has been disconnected. Bear in mind that the liquid in the pipe may be dangerous or extremely hot. Consult any relevant regulations.

The pipes must be depressurised before opening any part of the circuit, as the PIG may escape at high speed and cause serious personal injury.

Do not leave parts loose on the floor.

When inspecting the equipment, ensure the necessary measures are in place to prevent falling of displaced objects and loss of control of the equipment, etc. Isolate the pneumatic and electrical supply and release any pressure. When starting up the equipment check that the actuator is in the correct position and the detectors are giving the correct signal.



The PIG and the discs inside the actuating carriage are magnetised. **DO NOT** place close to metal components as they have a strong magnetic attraction. **DO NOT** leave the components on metal tables or benches during handling. **DO NOT** place close to metal tools and/or objects that can be attracted by the magnetic field.

When handling the magnetic discs, **DO NOT** place any part of your body between a disc and a metal component, and/or another disc, as they have a very strong magnetic pull. Establish the safety measures required to be able to handle these items without risk.

The working lifetime of the PIG greatly depends on the quality of the installation including the interior finishing of pipes, welds, cleanliness, and any deformity that may affect the smooth movement of the PIG.



All electrical work should be carried out by authorised personnel.

1.4.4. In compliance with the instructions

Any non-fulfilment of the instructions may result in a risk for the operators, the environment and the machine, and may result in the loss of your right to claim damages.

This non-fulfilment may result in the following risks:

- Failure of important functions of the machines/plant.
- Failure of specific maintenance and repair procedures.
- Possibility of electric, mechanical and chemical risks.
- Will place the environment in danger due to the release of substances.

1.5. GUARANTEE.

Any guarantee will be cancelled immediately and as a matter of law and, in addition, we will require compensation for any claims of civil liability presented by third parties, in case:

- The installation and maintenance work has not been carried out according to the instructions of this manual.
- The repairs are not carried out by our personnel or have been carried out without our written authorisation.
- The parts used are not INOXPA genuine parts.
- Modifications have been carried out on our materials without written authorisation.
- The material has been badly used, incorrectly used, or used with negligence or has not been used according to the indications and intended use specified in this manual.

The general conditions of delivery already in your possession are also applicable.

Please do not hesitate to contact us in case of doubts or if more detailed explanations are required on specific data (adjustments, assembly, disassembly, etc.).

2. Table of Contents

1.		
	1.1. Instruction manual	3
	1.2. Instructions for start-up	3
	1.3. Safety	3
	1.4. General safety instructions	3
	1.5. Guarantee	5
2.		
3.		
	3.1. Check the shipment	7
	3.2. Delivery and unpacking	7
	3.3. Identification	8
	3.4. Locations	8
	3.5. Installation	8
	3.6. Inspecting and checking	8
	3.7. Actuator air connection	8
4.		
	4.1. Start-up	9
	4.2. Operation	9
5.		
6.		
	6.1. General information	11
	6.2. Maintenance	11
	6.3. Cleaning	12
7.		
	7.1. Disassembly/Assembly of the equipment	14
	7.2. Disassembly/Assembly of the actuator carriage.	15
	7.3. Pig Position	16
	7.4. Orientation of the equipment	17
	7.5. Fluid connections	17
	7.6. Detector positioning	18
8.		
	8.1. Technical Specifications	19
	Recommendations for use	19
	8.2. Equipment dimensions	20
	8.3. Steripig exploded view and part list	21
	8.4. Pig detector exploded and part list	23

Operating I

3. Receipt and installation

3.1. CHECK THE SHIPMENT

On receiving the equipment verify that it agrees with the delivery note.

INOXPA will inspect all the equipment before packing, although it cannot guarantee that the merchandise will arrive intact to the user. For this reason, the equipment received should be checked and, if it is found to be damaged or incomplete the carrier should submit a report as soon as possible.

All equipment has a serial number shown on a nameplate. Include this number in all documents and correspondence. The equipment will have a nameplate with the following information.

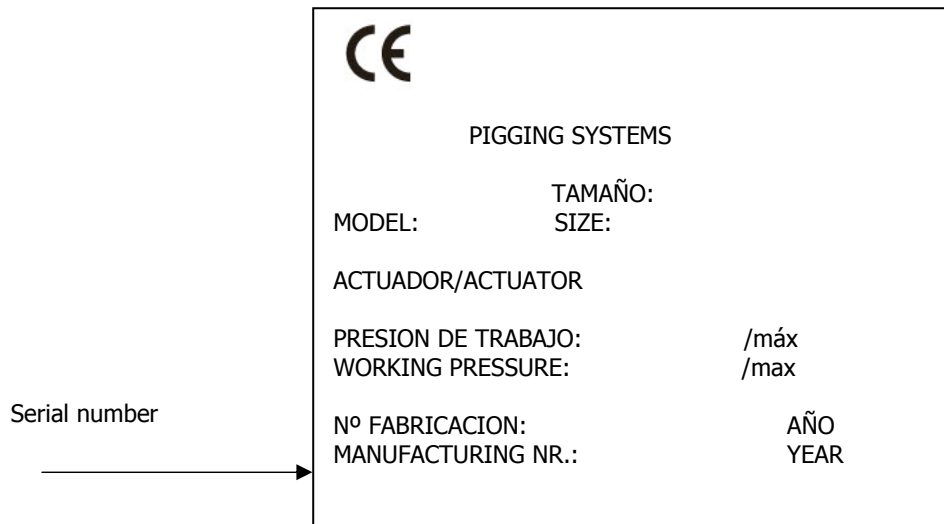

3.2. DELIVERY AND UNPACKING



INOXPA will not be responsible for the inappropriate unpacking of the equipment and its components.

3.2.1. Delivery:

Check all the components against the delivery note

- Full equipment
- Spare Parts (if supplied).
- Instruction manual.

3.2.2. Unpacking:

- Remove all traces of packing materials from the equipment.
- Inspect the equipment or its constituent parts for possible damage caused during transport.
- Avoid any possible damage when handling the equipment.

3.3. IDENTIFICATION

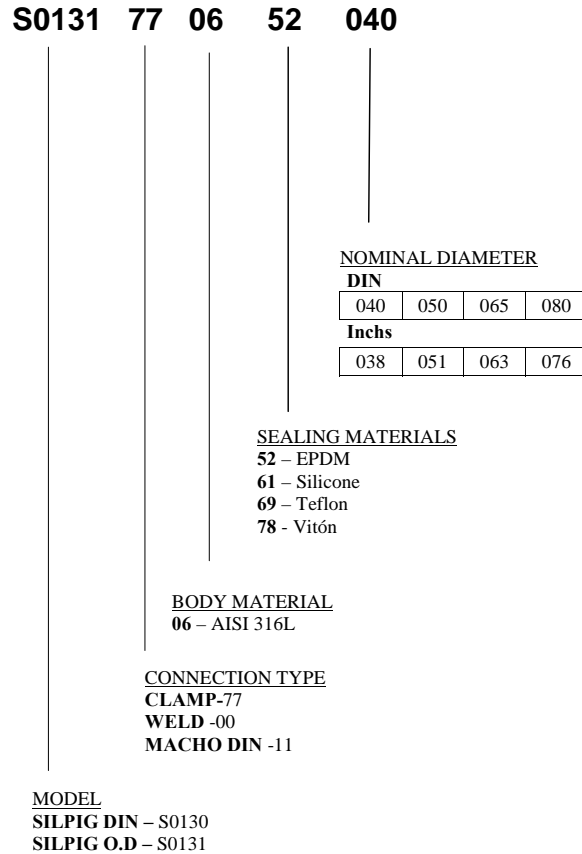

The buyer or user will be responsible for the assembly, installation, starting and operation of the equipment.

3.4. LOCATIONS

Place the equipment in such a way as to facilitate inspections and checks. Leave sufficient room around the equipment for service, disassembly and maintenance operations. It is very important to be able to access the air-connection of the actuator, even when in operation.

3.5. INSTALLATION

Once the location of the equipment has been established, install in the pipework using the necessary fittings. Excessive stress should be avoided during the installation of the equipment and special attention should be given to the following:

- Vibration which may be produced in the installation.
- Expansion of the pipes during circulation of hot liquids.
- Correct and adequate support
- Use of correct fittings and seals.

3.6. INSPECTING AND CHECKING

The following should be checked before operation:

- The PIG is magnetised and correctly located by the actuator.
- The actuator operates correctly by applying air three or four times in both directions and noting the movement of the PIG.
- The actuator moves the PIG inside the body.
- All detectors operate correctly.
-

3.7. ACTUATOR AIR CONNECTION

- Connect and check the air connections (1/8" Gas thread) to the double acting actuator.
- Check the air pressure and quality (use clean air free of oils, chemical products, or any other product that could damage the actuator).
- Mind the quality of the compressed air according to the specifications described in chapter 8 *Technical Specifications*.

4. Start-up

The start-up of the equipment can be carried out provided the instructions indicated in Chapter 3 – *Receiving and Installation* are followed.

4.1. START-UP



Before start-up, the responsible persons should be duly informed of the operation of the equipment and the safety instructions to be followed. This instruction manual should be available to personnel at all times.

The following should be taken into consideration before starting up the equipment:

- Check that the installation is completely free from any traces of welding or other foreign matter. Carry out the cleaning of the system if required.
- Check that the actuator introduces the PIG into the piping system correctly and smoothly.
- Check that the compressed air pressure at the intake to the actuator complies with the Technical Specifications (*Chapter 8*).
- Mind the quality of the compressed air according to the specifications described in chapter 8 Technical Specifications.
- Check that the equipment is moving smoothly. If necessary, lubricate with special grease or soapy water.
- Check for possible leaks
- Start up the equipment.
-

4.2. OPERATION



Do not modify the operating parameters for which the equipment has been designed without written prior authorisation from INOXPA.

Do not touch the moving parts of the coupling between the actuator and the body when the actuator is connected to the compressed air.

Danger of burns! Do not touch the equipment or pipes when hot liquids are circulating or when cleaning and/or sterilisation are being carried out.

5. Operating Problems, Causes and Solutions

PROBLEM	CAUSE/EFFECT	SOLUTION
EXTERNAL LEAK.	The main seal is worn or deteriorated.	<ul style="list-style-type: none"> • Replace the seals. • Replace the seals with others of different material and more appropriate for the product.
THE PIG HAS BEEN INCORRECTLY INTRODUCED OR RECEIVED.	<p>Incorrect operation of the actuator.</p> <p>Worn actuator components.</p> <p>Dirt in actuator.</p>	<ul style="list-style-type: none"> • • Check that the air connections are correct. • Check the actuator. • Check the compressed air pressure. •
THE PIG DETECTORS ARE NOT DETECTING	<p>The PIG is damaged or blocked up.</p> <p>The detectors are not working correctly</p> <p>The PIG is being driven by the compressed air at high speed and does not give the sensor time to detect it as it passes.</p>	<ul style="list-style-type: none"> • • Recover the PIG. Use a detection pen to find the ball in the installation. • Replace the PIG • Check the connection • Lower the air pressure
PREMATURE WEAR OF THE PIG	The PIG is driven by compressed air at high speed, creating considerable friction and hammering against the PIG deflector.	<ul style="list-style-type: none"> • • Lower the air pressure

6. Maintenance

6.1. GENERAL INFORMATION

This equipment, just like any other mechanical components, requires maintenance. The instructions contained in this manual cover the identification and replacement of spare parts. The instructions have been prepared for maintenance personnel and for those responsible for the supply of spare parts.



Carefully read Chapter 8. *Technical Specifications*.

All replaced material should be duly scrapped/recycled according to the directives in effect in the area.

Assembly and disassembly of the equipment must only be carried out by qualified staff.

Before beginning the maintenance work, ensure that the compressed air is disconnected and the pipes are not pressurised.

6.2. MAINTENANCE

The following is recommended for appropriate maintenance:

- A regular inspection of the equipment and its components.
- Keep a record of the operation of each component noting any problems.
- Always have spare seals in stock.

During maintenance, pay particular attention to the possible dangers identified in this manual.



Do not touch moving parts when the actuator is connected to the compressed air.

The equipment and pipes should not be pressurised during maintenance.

The equipment should not be hot during maintenance. Danger of burns!

6.2.1. Maintenance of the seals

REPLACEMENT OF SEALS	
Preventive maintenance	Replace after twelve (12) months.
Maintenance after a leak	Replace at the end of the process.
Scheduled maintenance	Regularly check that there are no leaks and that the valve is operating smoothly. Keep a record for the equipment. Use statistics to plan inspections.
Lubrication	During assembly, apply lubricants compatible with the seal material. See the following table.

SEAL COMPONENT	LUBRICANT	Class NLGI DIN 51818
NBR/ FPM/ VMQ	Klübersynth UH 1 64-2403	3
EPDM/ NBR/ FPM	PARALIQ GTE 703	3

The preventive maintenance periods may vary according to the working conditions to which the equipment is subjected: Temperature, pressure, number of operations per day, type of cleaning solutions used, etc.

6.2.2. Storage

Storage of the equipment should be carried out in an enclosed area, under the following conditions:

Temperature from 15°C to 30°C
Relative humidity <60%

Open-air storage of the equipment is NOT allowed.

6.2.3. PIG Maintenance

The wear of the PIG greatly depends on the quality of the installation including the surface finish of the pipework, welds, cleanliness, and anything that impedes the proper passage of the ball. It is also influenced by the driving medium, frequency of use, etc. Regular inspection is therefore recommended with the frequency being dependant upon the characteristics of the installation and its use.

Visually check that the PIG has not been deformed, worn, or cracked. The PIG must be replaced if any such defects are detected.

6.2.4. Spare parts

To request spare parts, it is necessary to indicate the type of equipment, the code and the description of the part which can be found in the *Technical Specification* chapter.

6.3. CLEANING



The use of aggressive cleaning products such as caustic soda and nitric acid may cause burns to the skin.

Use rubber gloves during the cleaning process.



Always use protective goggles.

6.3.1. Automatic CIP (cleaning-in-place)

If the equipment is installed in a system which is cleaned in place disassembly will not be required.

Cleaning solutions for CIP processes.

Only use clean water (chlorine-free) to mix with the cleaning agents:

a) Alkaline solution: 1% by weight of caustic soda (NaOH) at 70°C (150°F)

1 Kg NaOH + 100 l. of water = cleaning solution

o

2.2 l. NaOH at 33% + 100 l. of water = cleaning solution

b) Acid solution: 0.5% by weight of nitric acid (HNO₃) at 70°C (150°F)

0.7 litres HNO₃ at 53% + 100 l. of water = cleaning



Check the concentration of cleaning solutions. This may cause the deterioration of the equipment seals.

To remove any remains of cleaning products, **ALWAYS** perform a final rinse with clean water on completion of the cleaning process.



Before beginning the disassembly and assembly work, clean the equipment inside and outside.

6.3.2. Automatic SIP (sterilization-in-place)

The process of sterilization with steam is applied to all the equipment including the pigging.



Do NOT start the equipment during the process of sterilization with steam.
The parts/materials suffer no damage if the indications specified in this manual are observed.

No cold liquid can enter the equipment till the temperature of the equipment is lower than 60°C (140°F).

Maximum conditions during the SIP process with steam or overheated water

- a) Max. temperature: 140°C / 284°F
- b) Max. time: 30 min
- c) Cooling: Sterile air or inert gas
- d) Materials: EPDM / PTFE (recommended)
FPM / NBR / VMQ (not recommended)

7. Assembly and Disassembly



Proceed with caution. There is danger of personal injury.

Assembly and disassembly of the equipment must only be carried out by qualified staff.

Always disconnect the compressed air before carrying out any assembly or disassembly operation. Do not touch moving parts when the actuator is connected to the compressed air.

The equipment and pipes should not be pressurised during assembly and disassembly.

The valve should not be hot during assembly and disassembly. Danger of burns!



The following tools are required to disassemble the valve:

- 4mm Allen key and 2 11mm fixed wrenches for equipment (DN- 1.5", DN-2", DN-40, and DN-50)
- 6mm Allen key and 2 17mm fixed wrenches for equipment (DN-2.5", DN-3", DN-65, and DN-80)

7.1. DISASSEMBLY/ASSEMBLY OF THE EQUIPMENT

Disassembly

1. Disconnect the compressed air from the actuator (10a).
2. Remove the actuating carriage (10a) by releasing the screws (23a).
3. Remove the clamp (34).
4. Split the body assembly (01a) from the end caps (12a) and remove gasket (61).
5. Extract the ball (65) and handle carefully as it is magnetic (see section 1.4.1)

Assembly

6. Place the gasket (61) on the end cap (12a)
7. Insert the ball
8. Connect the end cap (12a) to the body (01a) using the clamp (34).
10. Secure the actuating carriage (10a) using the screws (23a).
11. Connect the compressed air.

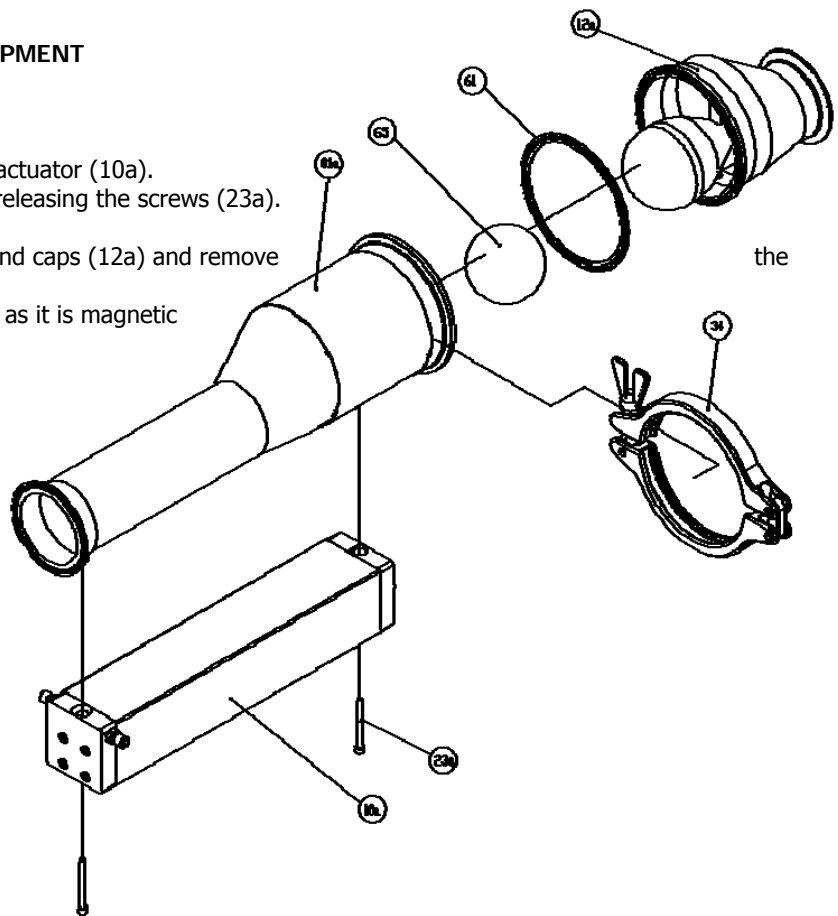

Before starting up the equipment, operate the actuator several times to ensure that it is moving smoothly.

7.2. DISASSEMBLY/ASSEMBLY OF THE ACTUATOR CARRIAGE.

Disassembly

13. 1. Disconnect the compressed air.
14. 2. Unscrew the nuts (37a)
15. 3. Remove the cap (12a)
16. 4. Unscrew screws (23c)
17. 5. Release the air lines and remove actuator (10b) from the cap (12b).
18. 6. Release the carriage (13) by unscrewing the screw (23b)
19. 7. Remove the magnetic discs (67) from the carriage (13) by unscrewing the pins (28)
20. 8. Handle the magnetic discs (67) carefully as they have a strong magnetic pull (see section 1.4.1)
21. 9. Unscrew connectors (18a) and (18b)

Assembly

22. 10. Connect the actuator (10b) to the cap (12b) with the screws (23c)
23. Place the magnetic discs (67) in the carriage (13) by fixing the pins (28)
24. Fit carriage (13) with actuator (10b) with screw (23b)
25. Thread the rods (11) into the cap (12b)
26. Fit the connectors (18a) and (18b)
27. Fit the tube (01b)
28. Locate the cap (12a)
29. Screw the nuts (37a) onto the rods (11)
30. Connect the compressed air.
- 1.

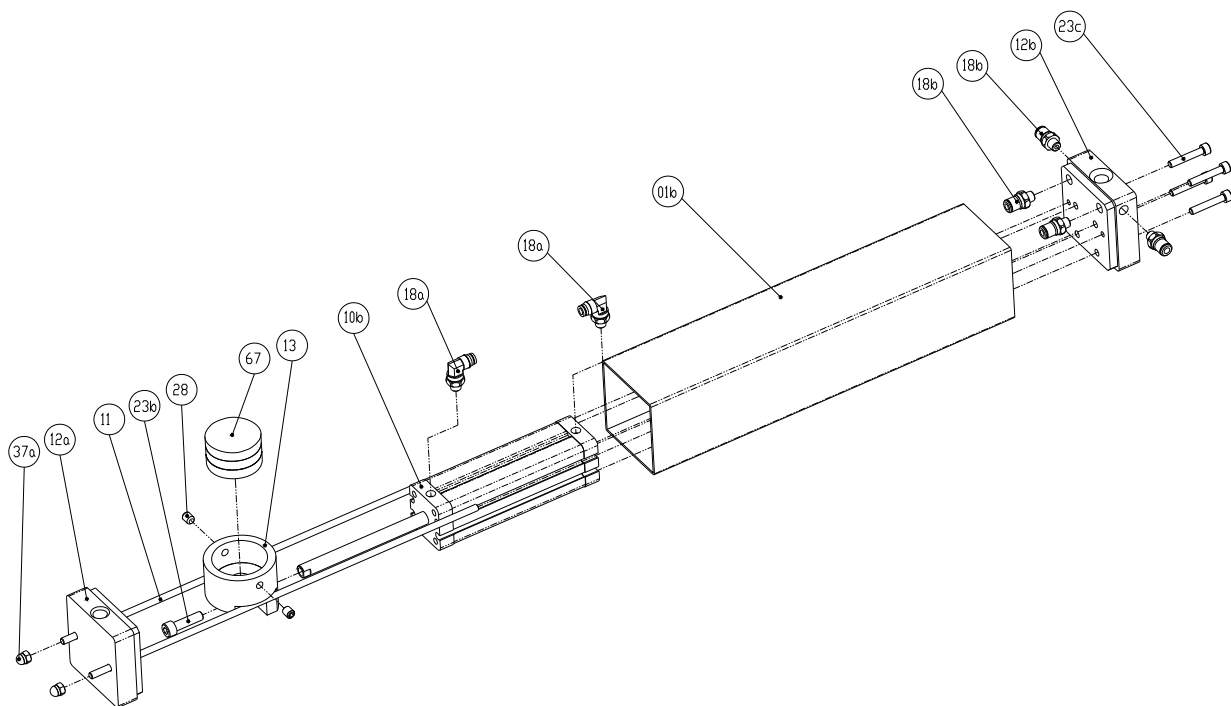

Before starting up the equipment, open and close the actuator several times to ensure that it is moving smoothly.

7.3. PIG POSITION

The position of the PIG (65) must be checked during assembly/disassembly or replacement of the actuator.

- POSITION 1: When the PIG is introduced into the pipe.
- POSITION 2: When the PIG is recovered and is in the resting position, or is awaiting the return of the PIG.

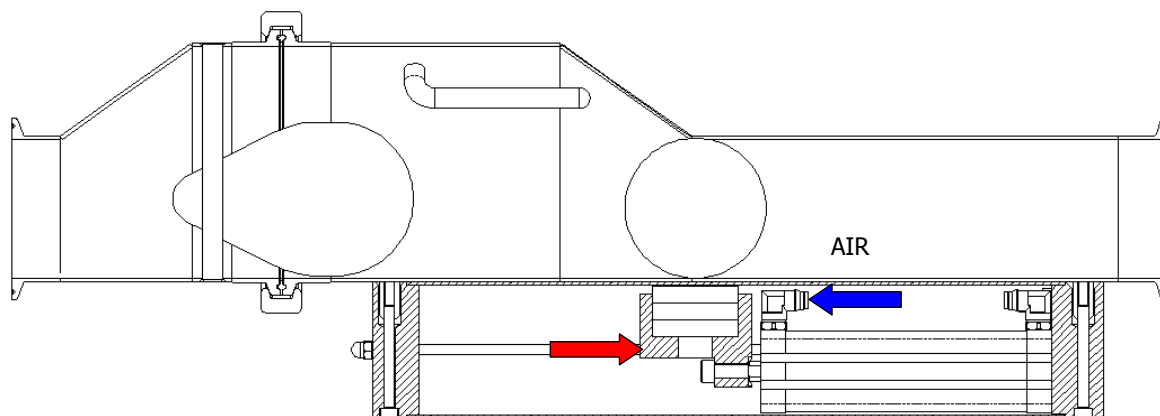

POSITION 1 (drive / recovery of ball)

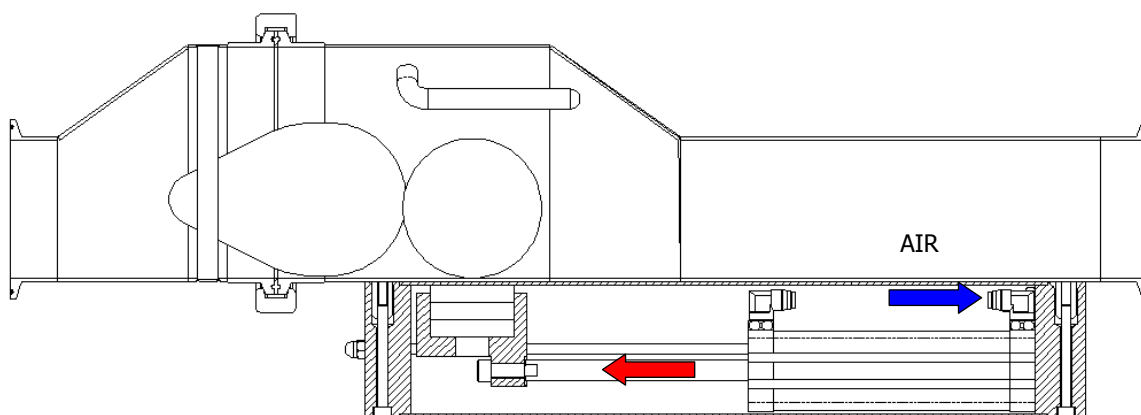

POSITION 2 (recovery)

AIR INLET TO INTRODUCE PIG INTO PIPE (POSITION 1)

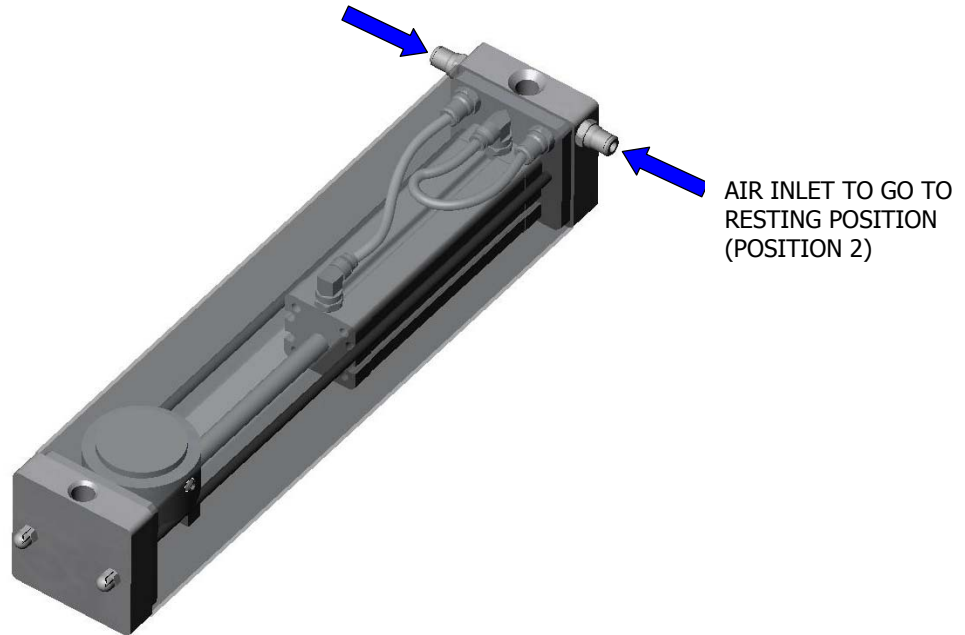

7.4. ORIENTATION OF THE EQUIPMENT

The equipment must be positioned either horizontally or vertically on the same centre line as the installation. If positioned vertically, the fluid must move upwards from below. That is, the fluid inlet at the bottom and the outlet at the top. The fluid inlets and outlets are positioned in the direction indicated in the section 7.5 – fluid connections

7.5. FLUID CONNECTIONS

The equipment has an inlet (1) and an outlet (2) for the fluid, which are connected to the main pipeline of the installation using appropriate fittings.



7.6. DETECTOR POSITIONING

The PIG detector is placed immediately after the STERIPIG outlet. NEVER before, as this could interfere with the PIG's magnetic field and produce an incorrect signal. Check that the detector is functioning correctly before starting up the equipment. **DO NOT** connect the detector before carefully reading the manual and the technical document for the detector. The connection must be made only by qualified staff.

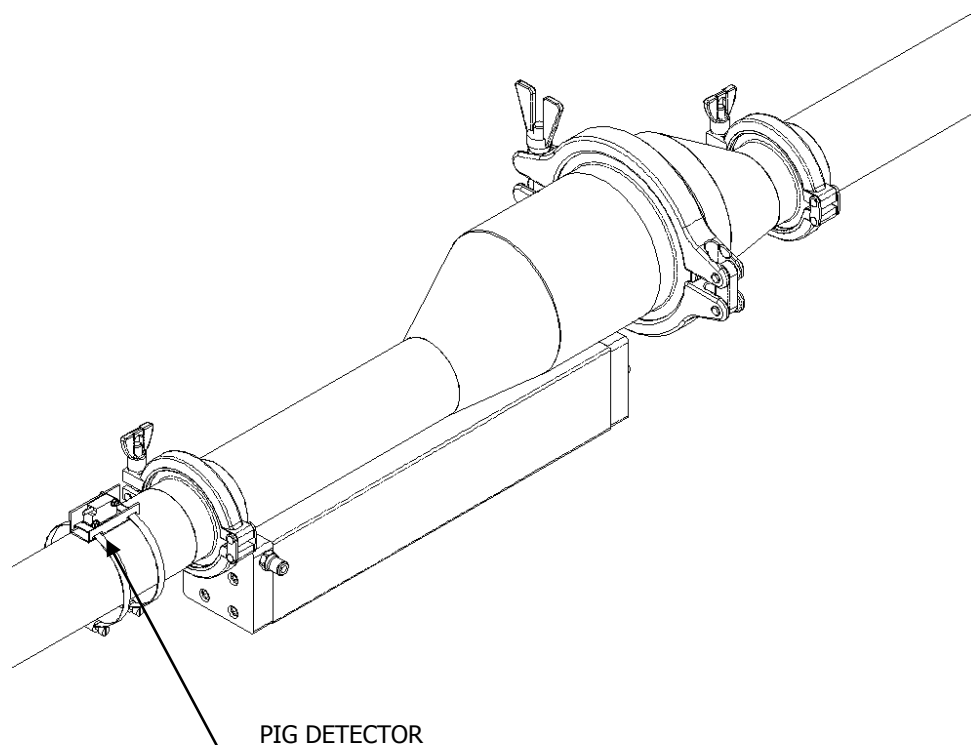

8. Technical Specifications

8.1. TECHNICAL SPECIFICATIONS

VALVE GENERAL DATA		
Maximum working pressure	DN-40 / 80 DN-1.5"/3"	10 bar
Maximum working temperature	121°C (250°F) EPDM standard seals (Other seal materials will be adapted for higher temperatures)	
Surface finish	In contact with the product: $Ra \leq 0.8 \mu m$ ($Ra \leq 0.4$ on request) External surfaces: satin-finished	

EQUIPMENT MATERIALS	
Parts in contact with the product	AISI 316L (1.4404)
Other metallic components	AISI 304 (1.4301)
Seals in contact with the product	EPDM (Standard) - NBR - VITON - SILICONE.
Surface finish	Parts in contact with the product $Ra < 0.8 \mu m$ ($Ra < 0.4 \mu m$ on request)
Type of connections	Welding, FIL-IDF, BS-RJT, SMS, Clamp, Flanges, Macon.

PNEUMATIC ACTUATOR GENERAL DATA	
Operation	Dual-effect (DA)
Compressed air pressure (Actuator)	5-7 bar (72-101 PSI)
Air compressed quality	According to DIN/ISO 8573.1 <ul style="list-style-type: none"> o <u>Solid particle content</u>: Quality class 3 / Particle size max. 5 micres / Particle density max. 5 mg/m³ o <u>Water content</u>: Quality class 4 / max. Dew point +2°C If the valve is used at higher altitudes or at low ambient temperatures, the dew point must be adapted accordingly o <u>Oil content</u>: Quality class 5, preferably oil free / max. 25 mg oil in 1 m³ air
Continuous working temperature	-10°C to +60°C
Air connections	R1/8" (Gas)

8.2. RECOMMENDATIONS FOR USE

The maximum admissible flowrate depends on the model and viscosity of the fluid driving the PIG.

If using compressed air as the PIG-driving fluid, it is advisable not to drive the PIG through dry-running pipes. The admissible air pressure depends on the model, conditions of use, and the state of the installation.

Also, increase the pressure gradually until it reaches the proper pressure. Generally the recommended initial pressure boosting product is between 1 to 2 bar, and may increase to a maximum of 4-5 bar, depending on the product and working conditions.



When there is no product in the pipe, the return in the PIG should be done at low pressure. If the impelling fluid is compressed air, a pressure of return between 0,5 – 1 bar is recommended, depending on the installation, model and conditions of use. In case of doubt, please consult INOXPA because a speed of return too high might seriously damage the PIG system.

Tools/assembly tightening torque

ALLEN KEY	4	5	6
Tightening torque	7 Nm	8Nm	10 Nm

8.3. EQUIPMENT DIMENSIONS

DN	D1	A	B	C	L	DN	D1	A	B	C	L
40	38	102	*	*	635	1 1/2"	34.8	100	72	69	640
50	50	108	91	83	574	2"	47.5	106	92	83	586
65	66	116	117	120	661	2 1/2"	60.2	113	120	120	661
80	81	123	115	120	663	3"	72.9	119	120	120	673

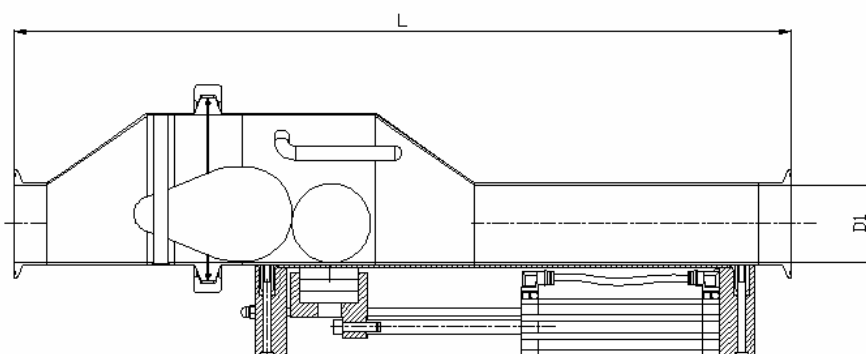
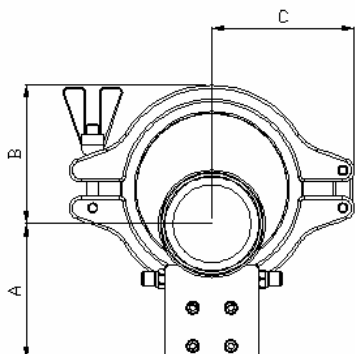

* To be consulted. It depends on the clamp available at any given time.

8.4. STERIPIG EXPLODED VIEW AND PART LIST

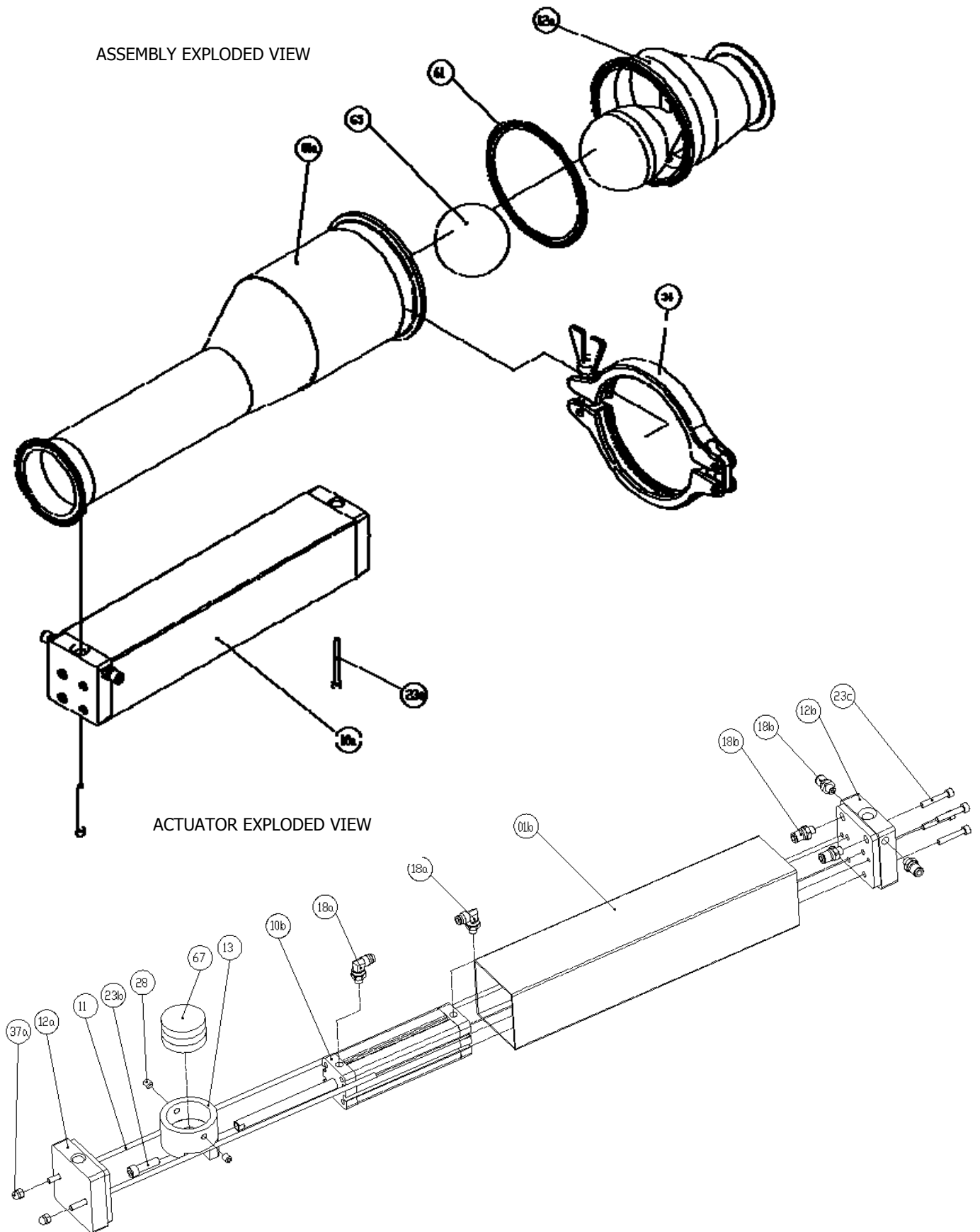

		ASSEMBLY PARTS CODE			
POS	DESCRIPTION	DN-80	DN-65	DN-50	DN-40
01a	BODY	1S030-0170006080	1S030-0170006065	1S030-0170006050	1S030-0170006040
10a	ACTUATOR CARRIAGE	1S030-1000003040	1S030-1000003040	1S030-1000003050	1S030-1000003040
12a	CASING/COVER	1S030-0270006080	1S030-0270006065	1S030-0270006050	1S030-0270006040
23a	ALLEN SCREW	1T112-0606004	1T112-0606004	1T112-0606004	1T112-0606004
34	CLAMP	R0720-004140	R0720-004140	R0720-004100	R0720-004065
61	CLAMP SEAL (EPDM)	R1760-050140	R1760-050140	R0760-050100	R1760-050076
	CLAMP SEAL (SILICONE)	R0760-061140	R0760-061140	R0760-060100	R1760-060076
	CLAMP SEAL (VITON)	R1760-080140	R1760-080140	R0760-078100	R1760-080076
65	PIG (SILICONE)	S8000-6100040	S8000-6100050	S8000-6100065	S8000-6100080
	PIG (EPDM)	S8000-5200040	S8000-5200050	S8000-5200065	S8000-5200080
	PIG (VITON)	S8000-7800040	S8000-7800050	S8000-7800065	S8000-7800080

		ASSEMBLY PARTS CODE			
POS	DESCRIPTION	DN-3"	DN-2 1/2"	DN-2"	DN-1 1/2"
01a	BODY	1S030-0170106076	1S030-0170106063	1S030-0170106050	1S030-0170106040
10a	ACTUATOR CARRIAGE	1S030-1000003040	1S030-1000003040	1S030-1000003050	1S030-1000003040
12a	CASING/COVER	1S030-0270106076	1S030-0270106063	1S030-0270106050	1S030-0270106040
23a	ALLEN SCREW	1T112-0606004	1T112-0606004	1T112-0606004	1T112-0606004
34	CLAMP	R0720-004140	R0720-004140	R0720-004100	R0720-004065
61	CLAMP SEAL (EPDM)	R1760-050140	R1760-050140	R0760-050100	R1760-050076
	CLAMP SEAL (SILICONE)	R0760-061140	R0760-061140	R0760-060100	R1760-060076
	CLAMP SEAL (VITON)	R1760-080140	R1760-080140	R0760-078100	R1760-080076
65	PIG (SILICONE)	S8000-6101076	S8000-6101063	S8000-6101050	S8000-6101040
	PIG (EPDM)	S8000-5201076	S8000-5201063	S8000-5201050	S8000-5201040
	PIG (VITON)	S8000-7801076	S8000-7801063	S8000-7801050	S8000-7801040

		ACTUATOR CARRIAGE PARTS CODE	
PART N°	DESCRIPTION	1S030-1000003040	1S030-1000003050
01b	PIPE	2S030-0100003040	2S030-0100003050
10b	PNEUMATIC PISTON	2S030-1000020040	2S030-1000020050
12a	ACTUATOR CAP 1	2S030-1210088040	2S030-1210088040
12b	ACTUATOR CAP 2	2S030-1200088040	2S030-1200088040
13a	CARRIAGE	2S030-1300084040	2S030-1300084040
18a	BEND CONNECTOR	1P120-0030000624	1P120-0030000624
18b	STRAIGHT CONNECTOR	1P110-0030000605	1P110-0030000605
23b	DIN 912 M8X30	1T112-0803004	1T112-0803004
23c	DIN 912 M6X35	1T112-0603504	1T112-0603504
28	DIN 916 M8X10	1T216-0801004	1T216-0801004
37a	M6 BLIND NUT	1T387-0600004	1T387-0600004
67	(Disc) MAGNETS	2S030-6700019040	2S030-6700019040

8.5. PIG DETECTOR EXPLODED AND PART LIST

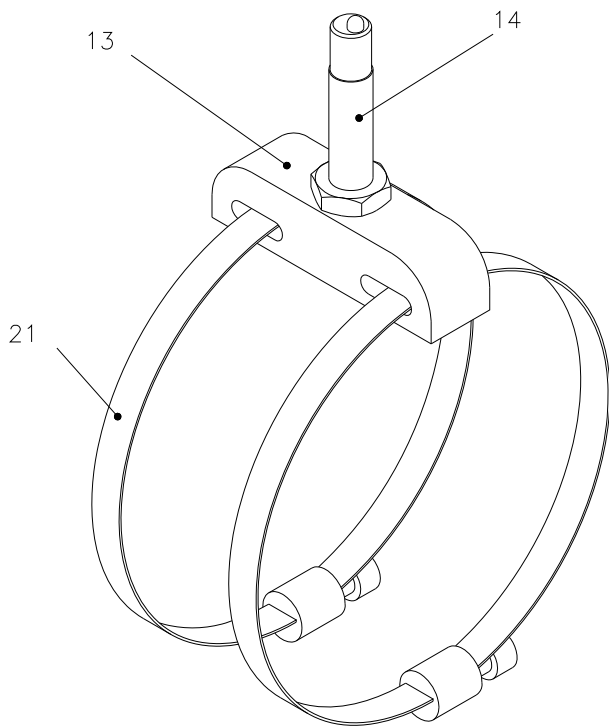

PART N°	DESCRIPTION	CODE			
		DN-1 1/2"	DN-2"	DN-2 1/2"	DN-3"
13	SUPPORT	1S900-42088040	1S900-42088040	1S900-42088040	1S900-42088040
14	DETECTOR	1S900-330000	1S900-330000	1S900-330000	1S900-330000
21	CLIP	1S900-34003065	1S900-34003065	1S900-34003040	1S900-34003040

<http://k-tep.com.ua/>

✉ k-tep@ukr.net

■ Office +38 044 2091823

■ МТС +38 066 9076563

■ Киевстар +38 098 3676414

Skype: [k-teppumps](#)

Замечания

Условия поставки: DDP склад г. Киев

Заметки

Время поставки рассчитано согласно дате предложения и изменяется в зависимости от даты подтверждения заказа.

Размещая заказ, покупатель принимает предложение и все спецификации, характеристики и условия, указанные в данном документе.