

REVISION HISTORY

REV	DESCRIPTION	DATE	APPROVED

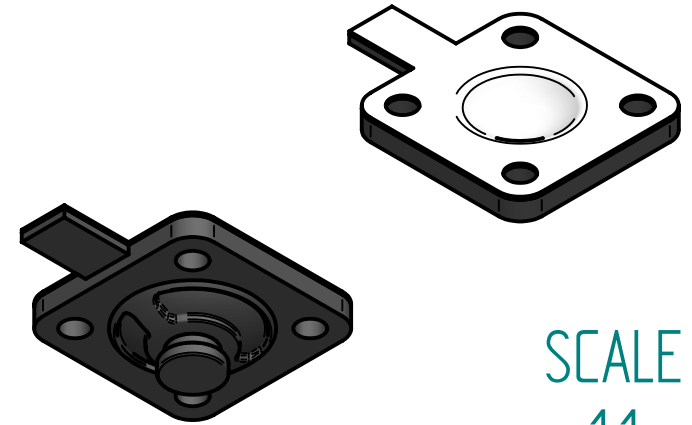

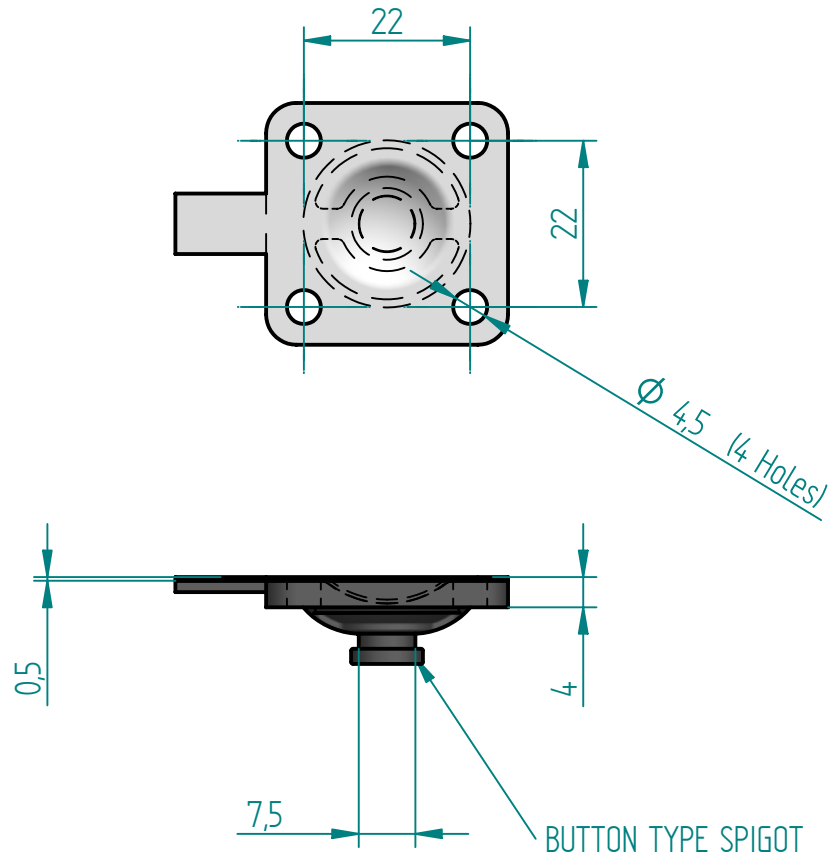

SCALE  
1:1

Replacement Diaphragm for :-

OEM PART NR. = 600008-M-52

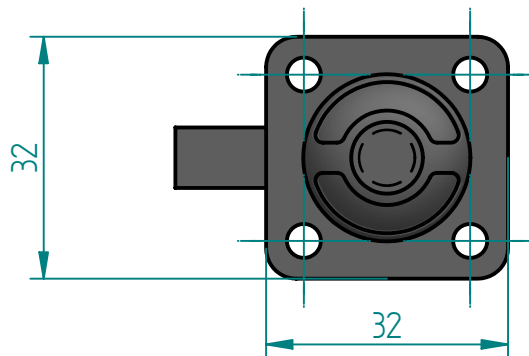
USED ON 1/2" (DN8,) Diaphragm Valve



	NAME	DATE	 <b>DIAPHRAGM DIRECT</b>
DRAWN	M. MC KEON	08/21/14	
CHECKED			
<b>Material -</b> <u><b>EPDM BACKING</b></u> <u><b>PTFE - DIAPHRAGM</b></u> Complies with CFR 177.2600 and Conforms to USP Class VI Biological Reactivity Tests Section #87 and #88			TITLE <b>DD03-GTFML</b>
SIZE A	<b>FOOT PRINT DIMENSIONS</b>		REV C
FILE NAME: DD03-GTFML.dft		SCALE: 1 : 1	ECO:0605 SHEET 1 OF 1

Disclaimer - Diaphragm Direct® does not manufacture, represent, nor sell OEM valves or diaphragms manufactured by any other company. Diaphragm Direct® brand diaphragms are not sponsored by any other manufacturers. Any name, model, part number, brand, image, material or referral is for descriptive purposes only. Diaphragm Direct® brand replacement diaphragms are guaranteed to fit OEM equipment and meet or exceed OEM specifications. Diaphragm Direct® brand replacement diaphragms are covered by the standard Diaphragm Direct® limited product warranty.