

REVISION HISTORY			
REV	DESCRIPTION	DATE	APPROVED

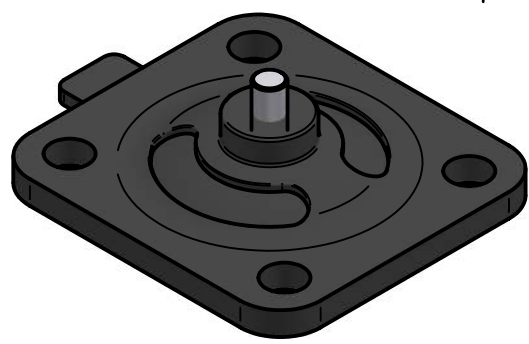

Replacement Diaphragm for :-
 OEM PART = 1P16 or S2 With Threaded Connection
 USED ON 1" (DN25) Diaphragm Valve

	NAME	DATE
DRAWN	M.MC KEON	07/15/18
CHECKED	M.MC KEON	07/22/18
Material - EPDM		
Complies with CFR 177.2600 and Conforms to USP Class VI Biological Reactivity Tests Section #87 and #88		

TITLE DD10-AE7	
SIZE A	REV <input type="checkbox"/>
FOOT PRINT DIMENSIONS	
FILE NAME: DD10-AE7.dft	
SCALE: 1 : 1	SHEET 1 OF 1

Disclaimer - Diaphragm Direct® does not manufacture, represent, nor sell OEM valves or diaphragms manufactured by any other company. Diaphragm Direct® brand diaphragms are not sponsored by any other manufacturers. Any name, model, part number, brand, image, material or referral is for descriptive purposes only. Diaphragm Direct® brand replacement diaphragms are guaranteed to fit OEM equipment and meet or exceed OEM specifications. Diaphragm Direct® brand replacement diaphragms are covered by the standard Diaphragm Direct® limited product warranty.