

1/4" - Whitworth (INSERT SCREW)

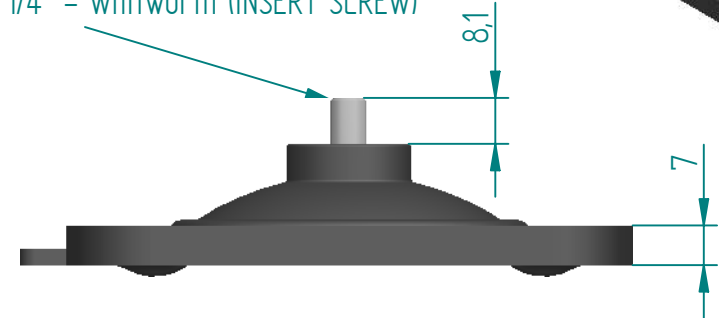

SCALE  
1:2



Replacement Diaphragm for .-  
OEM PART = 600040-M-13  
USED ON 1.5" (DN40) Diaphragm Valve

Disclaimer - Diaphragm Direct® does not manufacture, represent, nor sell OEM valves or diaphragms manufactured by any other company. Diaphragm Direct® brand diaphragms are not sponsored by any other manufacturers. Any name, model, part number, brand, image, material or referral is for descriptive purposes only. Diaphragm Direct® brand replacement diaphragms are guaranteed to fit OEM equipment and meet or exceed OEM specifications. Diaphragm Direct® brand replacement diaphragms are covered by the standard Diaphragm Direct® limited product warranty.

REVISION HISTORY			
REV	DESCRIPTION	DATE	APPROVED

	NAME	DATE
DRAWN	M.MC KEON	09/25/17
CHECKED	M.MC KEON	11/20/17

**Material - EPDM**

Complies with CFR 177.2600  
and Conforms to  
USP Class VI Biological Reactivity  
Tests Section #87 and #88



TITLE  
**DD15-GE7**

SIZE A	<b>FOOT PRINT DIMENSIONS</b>	REV D
-----------	------------------------------	----------

FILE NAME: DD15-GE7.dft

SCALE: 1:133	4790/339	SHEET 1 OF 1
--------------	----------	--------------