

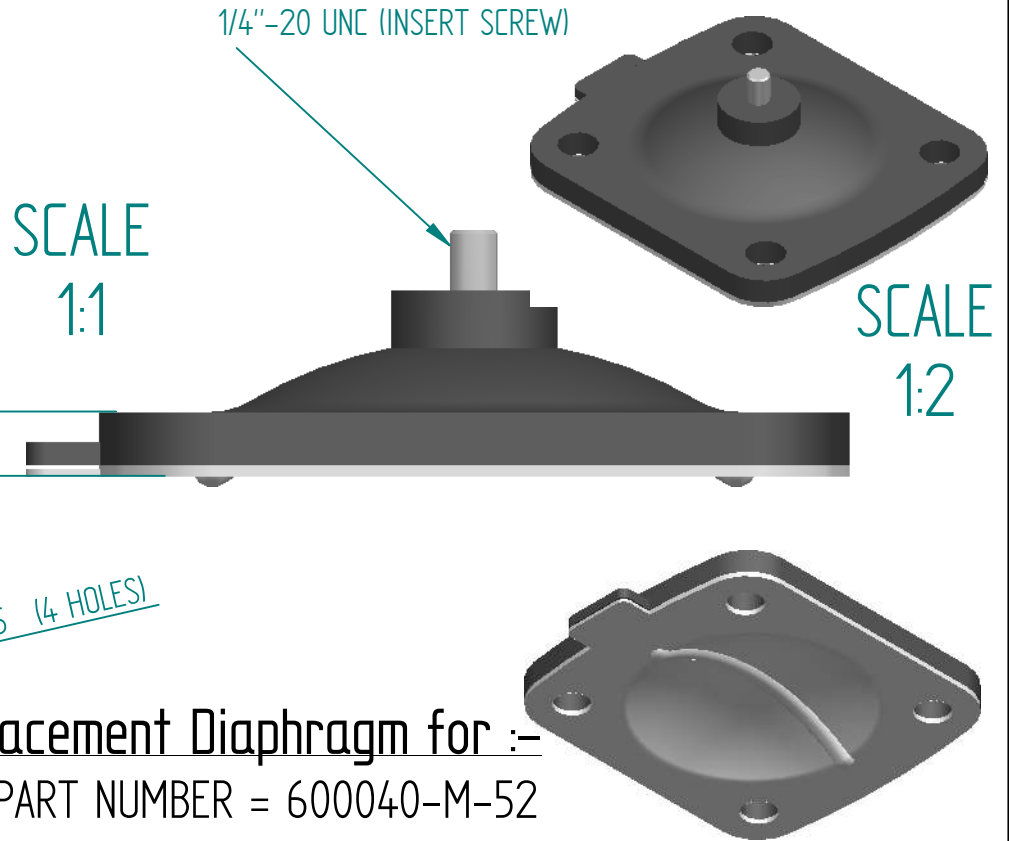

REVISION HISTORY			
REV	DESCRIPTION	DATE	APPROVED



Replacement Diaphragm for :-
 OEM PART NUMBER = 600040-M-52
 USED ON 1.5" (DN40) Diaphragm Valve

NAME	DATE	 DIAPHRAGM DIRECT	
DRAWN	08/29/14		
CHECKED			
<u>Material -</u>		TITLE	
<u>EPDM BACKING</u>		DD15-GTFM	
<u>PTFE - DIAPHRAGM</u>		SIZE	
Complies with CFR 177.2600 and Conforms to		A	
USP Class VI Biological Reactivity Tests Section #87 and #88		FOOT PRINT DIMENSIONS	
		REV	
		B	
		FILE NAME: DD15-GTFM.dft	
		SCALE: 1 : 1	ECD:0605
		SHEET 1 OF 1	

Disclaimer - Diaphragm Direct® does not manufacture, represent, nor sell OEM valves or diaphragms manufactured by any other company. Diaphragm Direct® brand diaphragms are not sponsored by any other manufacturers. Any name, model, part number, brand, image, material or referral is for descriptive purposes only. Diaphragm Direct® brand replacement diaphragms are guaranteed to fit OEM equipment and meet or exceed OEM specifications. Diaphragm Direct® brand replacement diaphragms are covered by the standard Diaphragm Direct® limited product warranty.