

REVISION HISTORY			
REV	DESCRIPTION	DATE	APPROVED

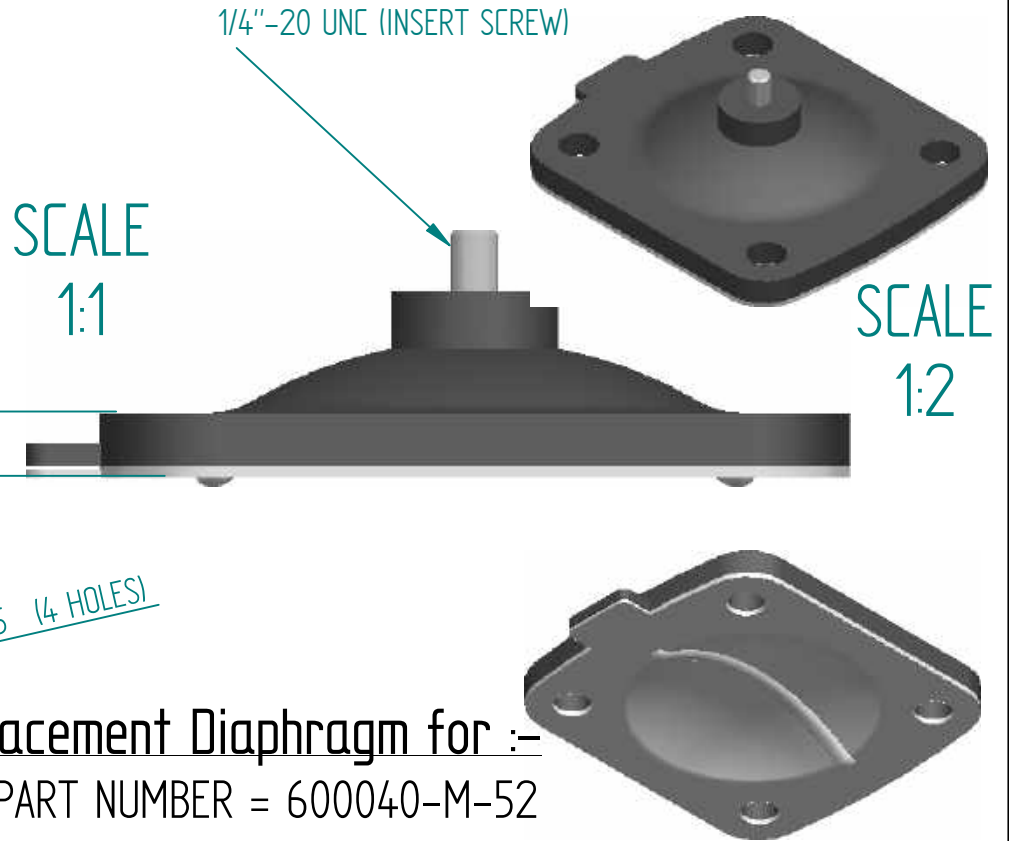

Replacement Diaphragm for :-  
 OEM PART NUMBER = 600040-M-52  
 USED ON 1.5" (DN40) Diaphragm Valve

	NAME	DATE
DRAWN	M.MC KEON	08/29/14
CHECKED		



**Material -**  
**PTFE laminate EPDM**  
**- DIAPHRAGM**

Complies with CFR 177.2600  
 and Conforms to  
 USP Class VI Biological Reactivity  
 Tests Section #87 and #88

TITLE		
DD15-GTFML		
SIZE	FOOT PRINT DIMENSIONS	REV
A		A
FILE NAME: DD15-GTFML.dft		
SCALE: 1 : 1	ECO:0605	SHEET 1 OF 1

Disclaimer - Diaphragm Direct® does not manufacture, represent, nor sell OEM valves or diaphragms manufactured by any other company. Diaphragm Direct® brand diaphragms are not sponsored by any other manufacturers. Any name, model, part number, brand, image, material or referral is for descriptive purposes only. Diaphragm Direct® brand replacement diaphragms are guaranteed to fit OEM equipment and meet or exceed OEM specifications. Diaphragm Direct® brand replacement diaphragms are covered by the standard Diaphragm Direct® limited product warranty.