

Ø 10.5 (4 Holes)

REVISION HISTORY			
REV	DESCRIPTION	DATE	APPROVED

SCALE
1:2

1/4" - 20 UNC (INSERT SCREW)

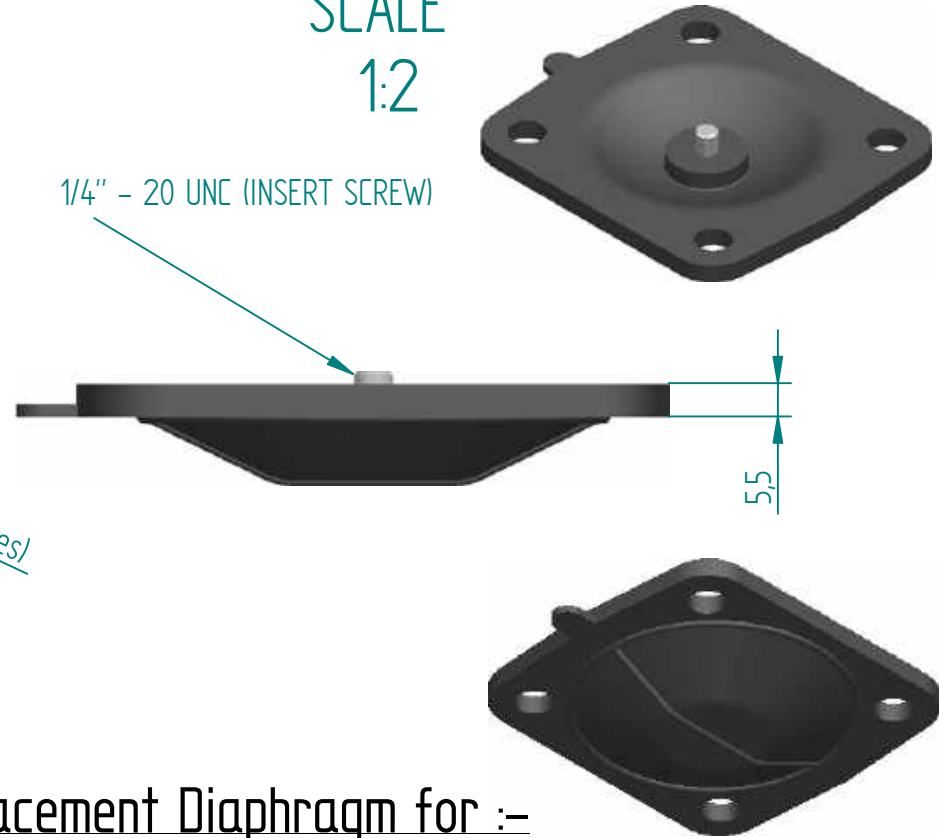

Replacement Diaphragm for :-
OEM PART = 41284 or 46606
USED ON 1.5" (DN40) Diaphragm Valve

	NAME	DATE		
DRAWN	M. MC KEON	08/21/14		
CHECKED			TITLE	
Material - EPDM			DD15-IE7	
Complies with CFR 177.2600 and Conforms to USP Class VI Biological Reactivity Tests Section #87 and #88			SIZE A	REV B
			FOOT PRINT DIMENSIONS	
			FILE NAME: DD15-IE7.dft	
SCALE: 1:125		ECC:0605	SHEET 1 OF 1	

Disclaimer - Diaphragm Direct® does not manufacture, represent, nor sell OEM valves or diaphragms manufactured by any other company. Diaphragm Direct® brand diaphragms are not sponsored by any other manufacturers. Any name, model, part number, brand, image, material or referral is for descriptive purposes only. Diaphragm Direct® brand replacement diaphragms are guaranteed to fit OEM equipment and meet or exceed OEM specifications. Diaphragm Direct® brand replacement diaphragms are covered by the standard Diaphragm Direct® limited product warranty.