

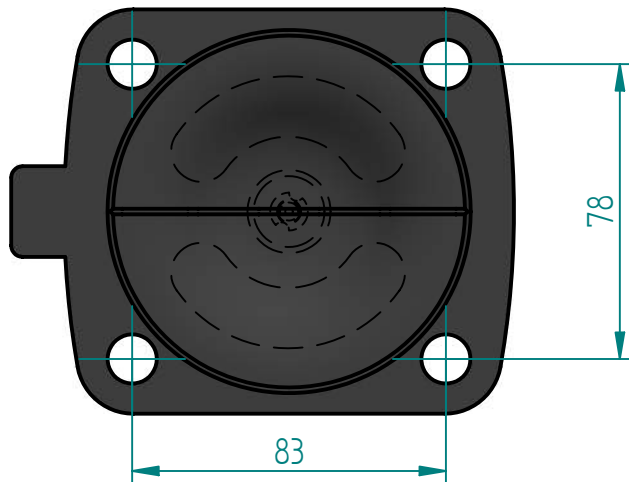

REVISION HISTORY

REV	DESCRIPTION	DATE	APPROVED

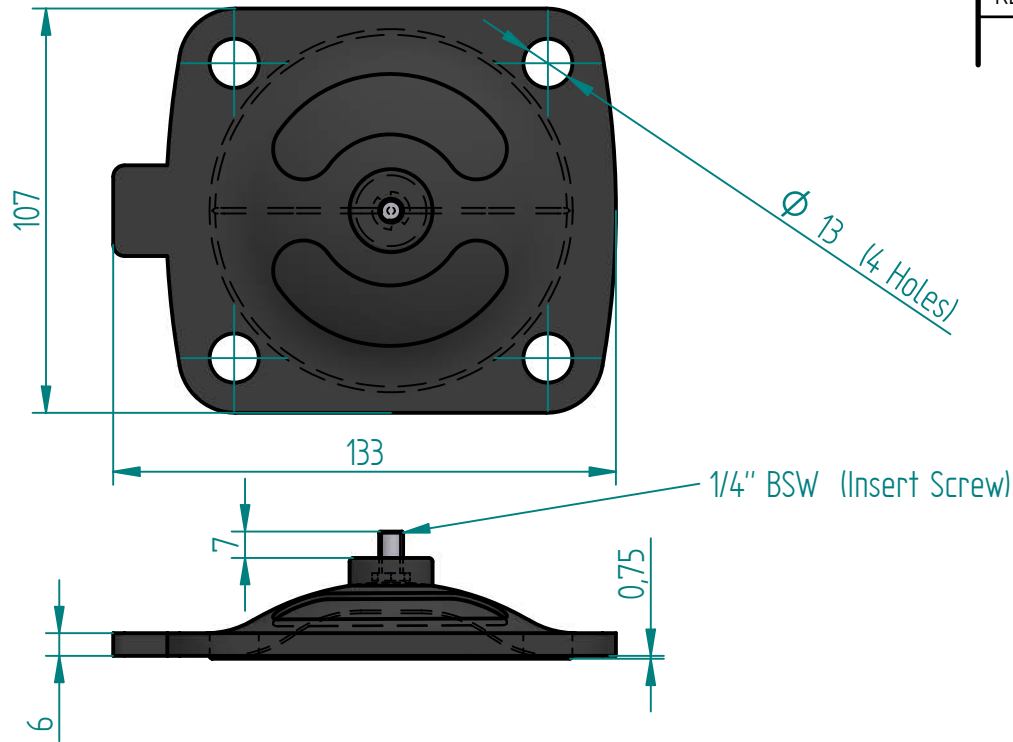
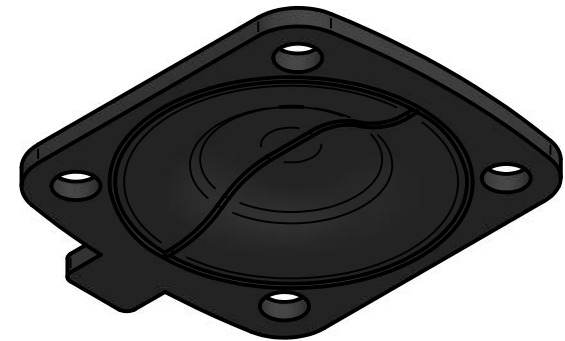
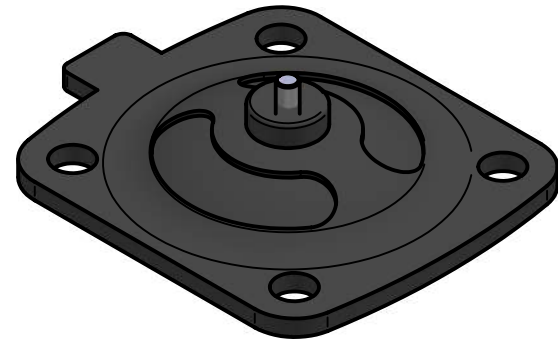

Replacement Diaphragm for :-  
 OEM PART = 1P32 With Threaded Connection  
 USED ON 2" (DN50) Diaphragm Valve

	NAME	DATE	 <b>DIAPHRAGM DIRECT</b>	
DRAWN	M Mc Keon	07/22/18		
CHECKED	M Mc Keon	07/22/18		
<b>Material - EPDM</b>			TITLE <b>DD20-AE7</b>	
Complies with CFR 177.2600 and Conforms to USP Class VI Biological Reactivity Tests Section #87 and #88			SIZE A	REV 0
			<b>FOOT PRINT DIMENSIONS</b> FILE NAME: DD20-AE7.dft	
SCALE: 1 : 2		1633-09-17-4	SHEET 1 OF 1	

Disclaimer - Diaphragm Direct® does not manufacture, represent, nor sell OEM valves or diaphragms manufactured by any other company. Diaphragm Direct® brand diaphragms are not sponsored by any other manufacturers. Any name, model, part number, brand, image, material or referral is for descriptive purposes only. Diaphragm Direct® brand replacement diaphragms are guaranteed to fit OEM equipment and meet or exceed OEM specifications. Diaphragm Direct® brand replacement diaphragms are covered by the standard Diaphragm Direct® limited product warranty.