

REVISION HISTORY			
REV	DESCRIPTION	DATE	APPROVED

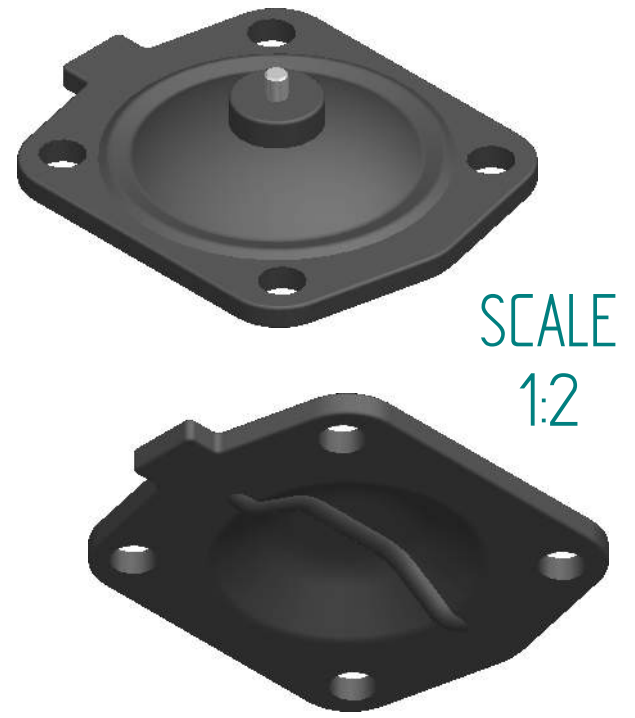

Replacement Diaphragm for :-
 OEM PART = 600050-M-13
 USED ON 2" (DN50) Diaphragm Valve

	NAME	DATE
DRAWN	M. MC KEON	09/25/17
CHECKED	M. MC KEON	04/15/18

Material - EPDM

Complies with CFR 177.2600
 and Conforms to
 USP Class VI Biological Reactivity
 Tests Section #87 and #88



TITLE		
DD20-GE7		
SIZE A	FOOT PRINT DIMENSIONS	REV C
FILE NAME: DD20-GE7.dft		
SCALE: 1:133	4281/339	SHEET 1 OF 1

Disclaimer - Diaphragm Direct® does not manufacture, represent, nor sell OEM valves or diaphragms manufactured by any other company. Diaphragm Direct® brand diaphragms are not sponsored by any other manufacturers. Any name, model, part number, brand, image, material or referral is for descriptive purposes only. Diaphragm Direct® brand replacement diaphragms are guaranteed to fit OEM equipment and meet or exceed OEM specifications. Diaphragm Direct® brand replacement diaphragms are covered by the standard Diaphragm Direct® limited product warranty.