

REVISION HISTORY			
REV	DESCRIPTION	DATE	APPROVED

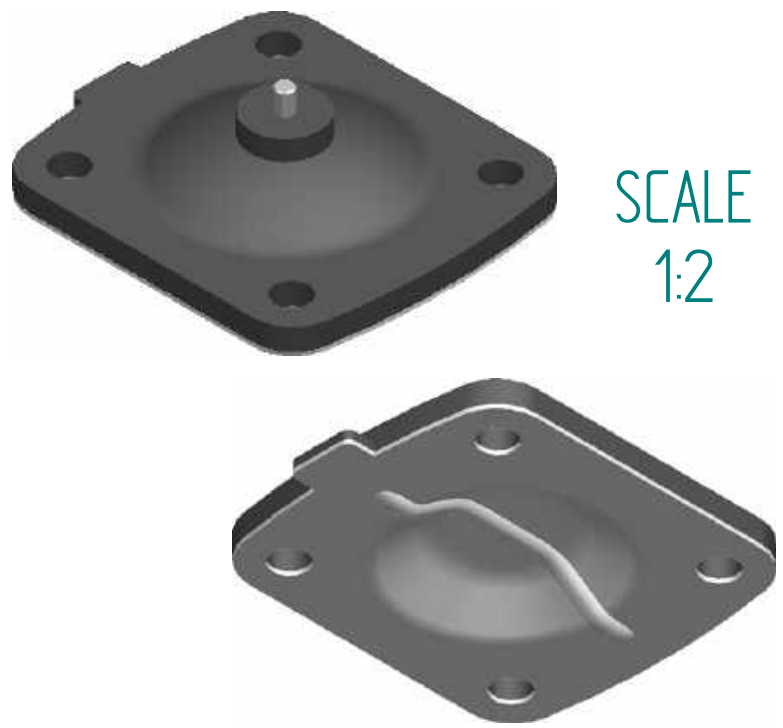

**Replacement Diaphragm for :-**  
 OEM PART NUMBER = 600050-M-52  
 USED ON 2" (DN50) Diaphragm Valve

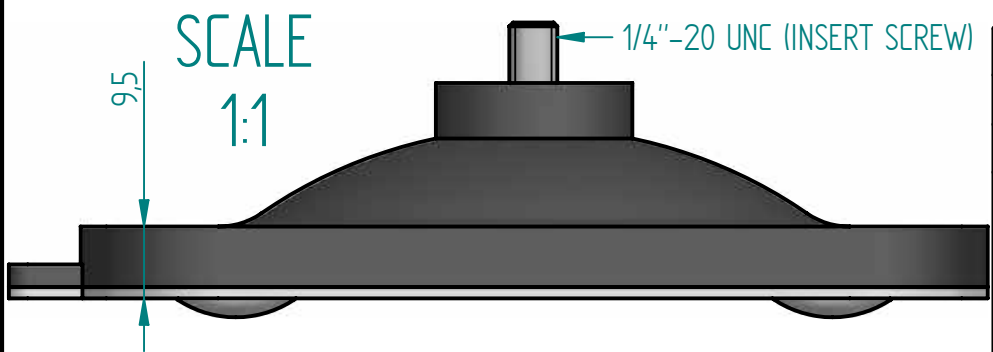

	NAME	DATE
DRAWN	M. MC KEON	08/21/14
CHECKED		



**Material -**  
**PTFE laminate EPDM**  
**- DIAPHRAGM**

TITLE  
**DD20-GTFML**

Complies with CFR 177.2600  
 and Conforms to  
 USP Class VI Biological Reactivity  
 Tests Section #87 and #88

SIZE	FOOT PRINT DIMENSIONS	REV
A		A

SCALE: 1 : 1	ECO:0605	SHEET 1 OF 1
--------------	----------	--------------

Disclaimer - Diaphragm Direct® does not manufacture, represent, nor sell OEM valves or diaphragms manufactured by any other company. Diaphragm Direct® brand diaphragms are not sponsored by any other manufacturers. Any name, model, part number, brand, image, material or referral is for descriptive purposes only. Diaphragm Direct® brand replacement diaphragms are guaranteed to fit OEM equipment and meet or exceed OEM specifications. Diaphragm Direct® brand replacement diaphragms are covered by the standard Diaphragm Direct® limited product warranty.