

REVISION HISTORY

REV	DESCRIPTION	DATE	APPROVED

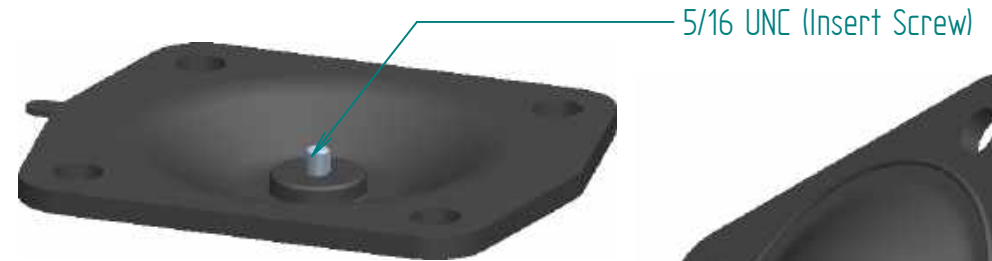

SCALE
1:2.5

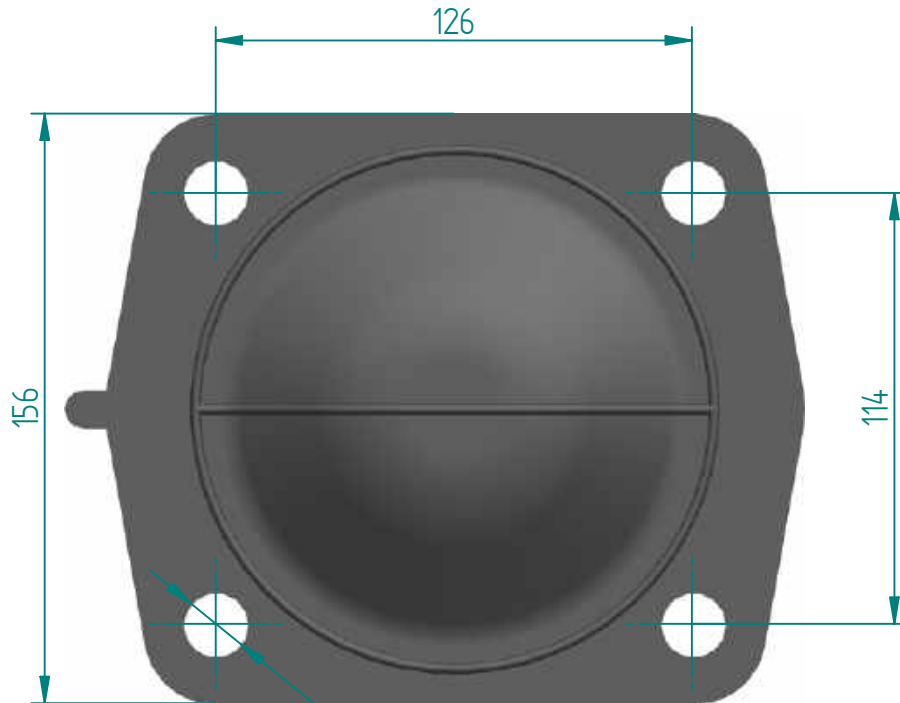

Ø 17 (4 Holes)

Replacement Diaphragm for :-
OEM PART = 41286 or 47002
USED ON 2.5" (DN65) Diaphragm Valves.

	NAME	DATE	 DIAPHRAGM DIRECT
DRAWN	M.MC KEON	08/21/14	
CHECKED			
<p>Material - EPDM</p> <p>Complies with CFR 177.2600 and Conforms to USP Class VI Biological Reactivity Tests Section #87 and #88</p>			<p>DD25-IE7 Same as DD30-IE7</p>
SIZE A	FOOT PRINT DIMENSIONS		REV C
FILE NAME: DD25-IE7.dft			
SCALE: 1:2 (mm)	ECD: 0605	SHEET 1 OF 1	

Disclaimer - Diaphragm Direct® does not manufacture, represent, nor sell OEM valves or diaphragms manufactured by any other company. Diaphragm Direct® brand diaphragms are not sponsored by any other manufacturers. Any name, model, part number, brand, image, material or referral is for descriptive purposes only. Diaphragm Direct® brand replacement diaphragms are guaranteed to fit OEM equipment and meet or exceed OEM specifications. Diaphragm Direct® brand replacement diaphragms are covered by the standard Diaphragm Direct® limited product warranty.