

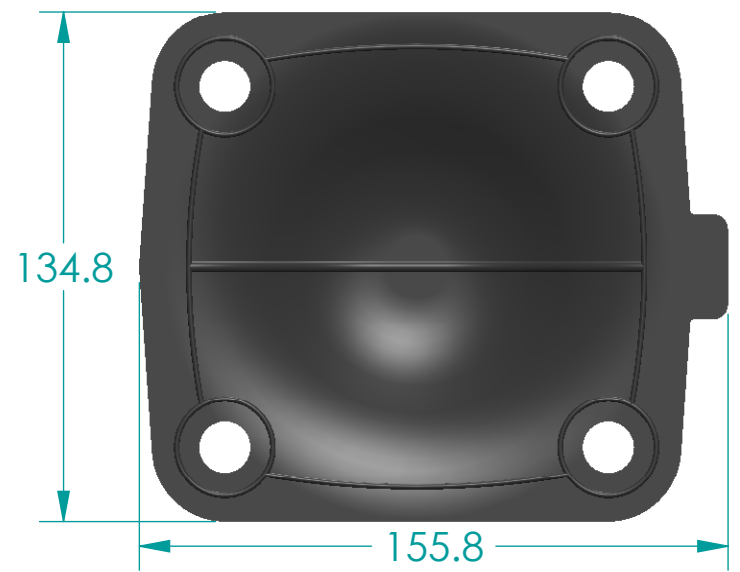

Revision History

Rev	Description	Date	Approved
D	OEM PART changed to DA065ER	05/12/21	JB

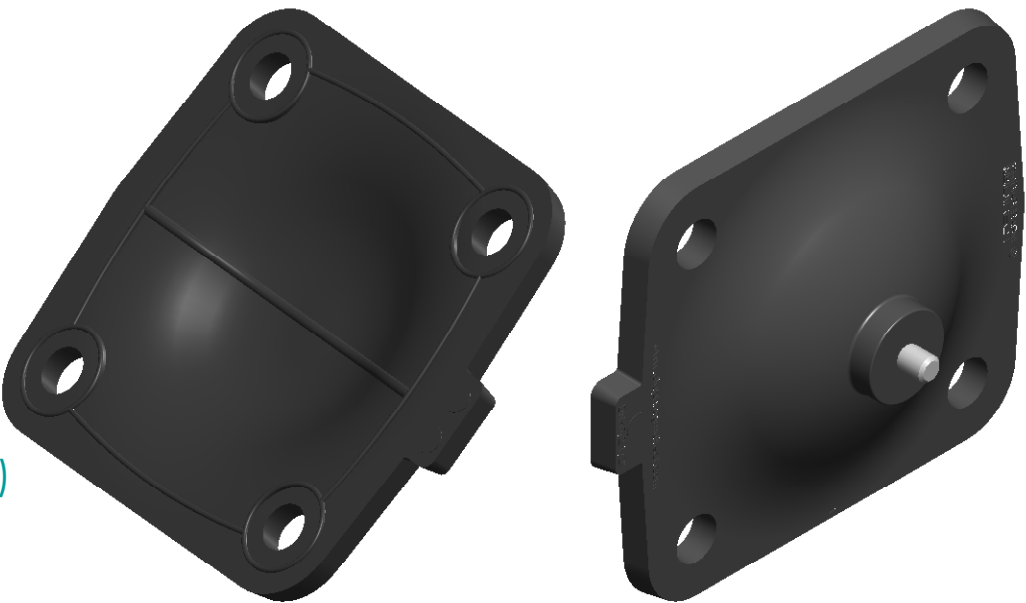
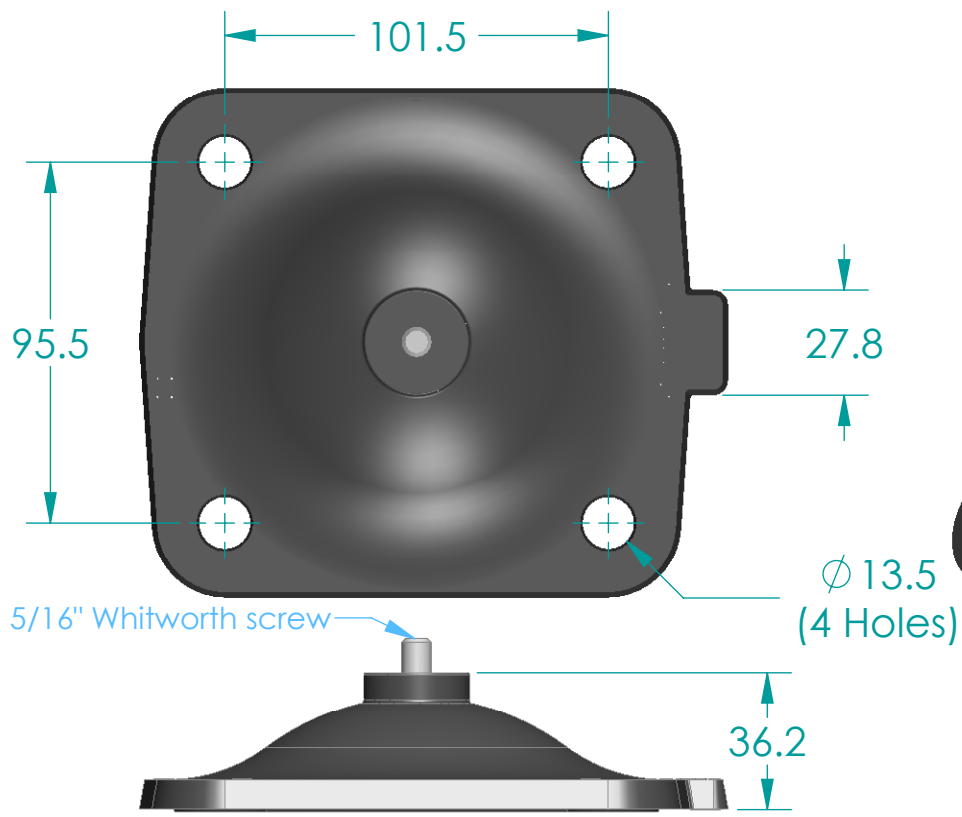

Replacement Diaphragm for:-
OEM PART = DA065ER
USED ON 2.5" (DN65) Diaphragm Valve

Disclaimer - Diaphragm Direct® does not manufacture, represent, nor sell OEM valves or diaphragms manufactured by any other company. Diaphragm Direct® brand diaphragms are not sponsored by any other manufacturers. Any name, model, part number, brand, image, material or referral is for descriptive purposes only. Diaphragm Direct® brand replacement diaphragms are guaranteed to fit OEM equipment and meet or exceed OEM specifications. Diaphragm Direct® brand replacement diaphragms are covered by the standard Diaphragm Direct® limited product warranty.

	NAME	DATE	 DIAPHRAGM DIRECT
DRAWN	M.Mc Keon	15/12/21	
CHECKED			
Material - EPDM Complies with CFR 177.2600 and Conforms to USP Class VI Biological Reactivity Tests Section #87 and #88			TITLE DD25-SE7
Size A	FOOT PRINT DIMENSIONS		Rev D
File Name:			DD25-SE7d
SCALE: 1:2			Sheet 1 of 1