

REVISION HISTORY

REV	DESCRIPTION	DATE	APPROVED

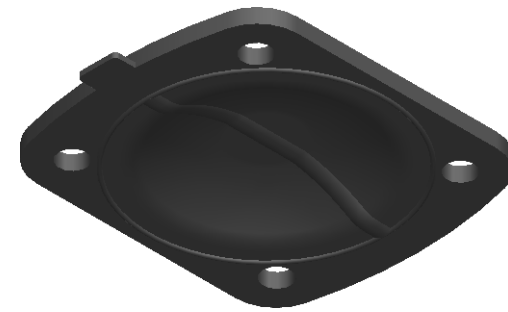
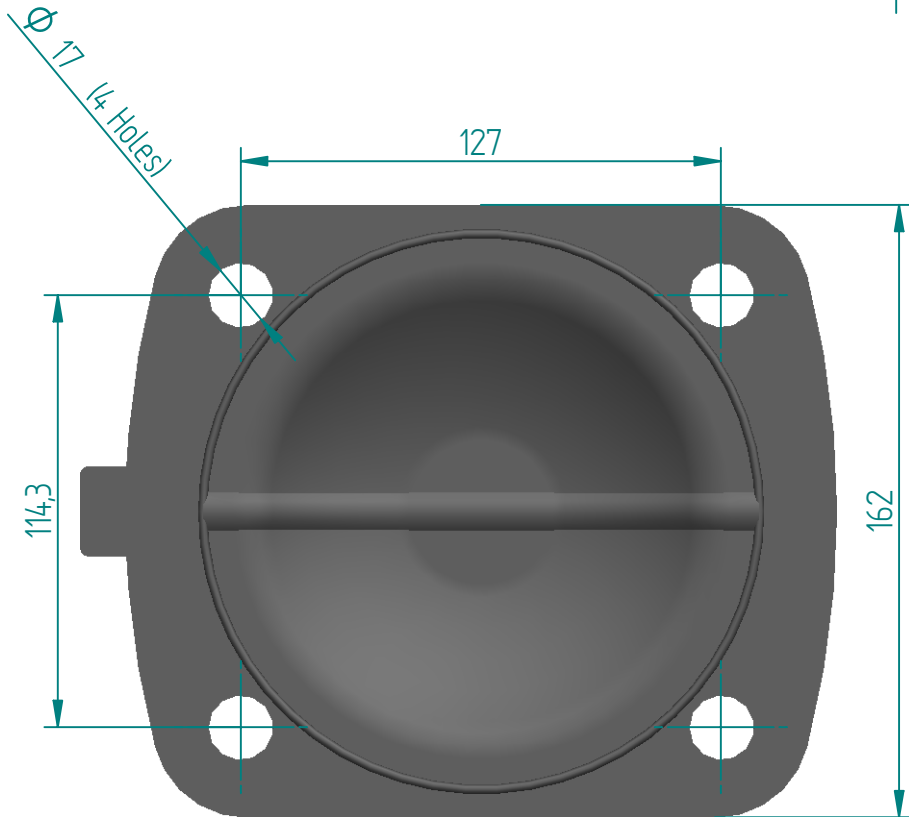
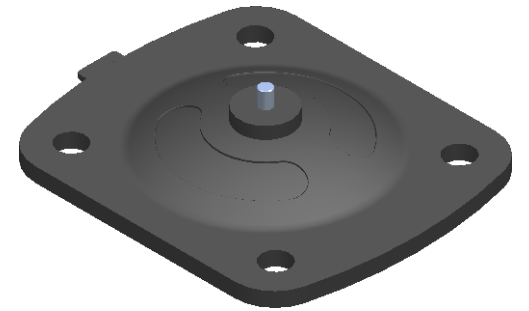
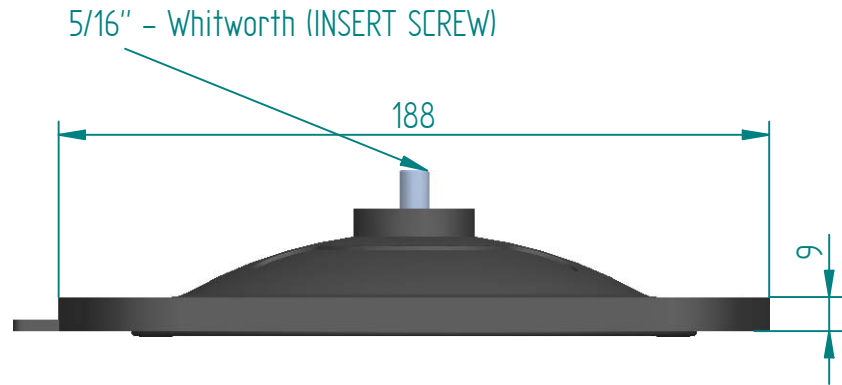

Scale
1:3.33

Replacement Diaphragm for :-
OEM PART = 600080-M-13
USED ON 3" (DN80) Diaphragm Valve

Disclaimer - Diaphragm Direct® does not manufacture, represent, nor sell OEM valves or diaphragms manufactured by any other company. Diaphragm Direct® brand diaphragms are not sponsored by any other manufacturers. Any name, model, part number, brand, image, material or referral is for descriptive purposes only. Diaphragm Direct® brand replacement diaphragms are guaranteed to fit OEM equipment and meet or exceed OEM specifications. Diaphragm Direct® brand replacement diaphragms are covered by the standard Diaphragm Direct® limited product warranty.

	NAME	DATE
DRAWN	M.MC KEON	09/18/14
CHECKED		

Material - EPDM
Complies with CFR 177.2600
and Conforms to
USP Class VI Biological Reactivity
Tests Section #87 and #88



TITLE DD30-GE7		
SIZE A	FOOT PRINT DIMENSIONS	REV C
FILE NAME: DD30-GE7.dft		
SCALE: 1:2 (mm)	ECO:0605	SHEET 1 OF 1