

REVISION HISTORY

REV	DESCRIPTION	DATE	APPROVED

SCALE
1:2.5

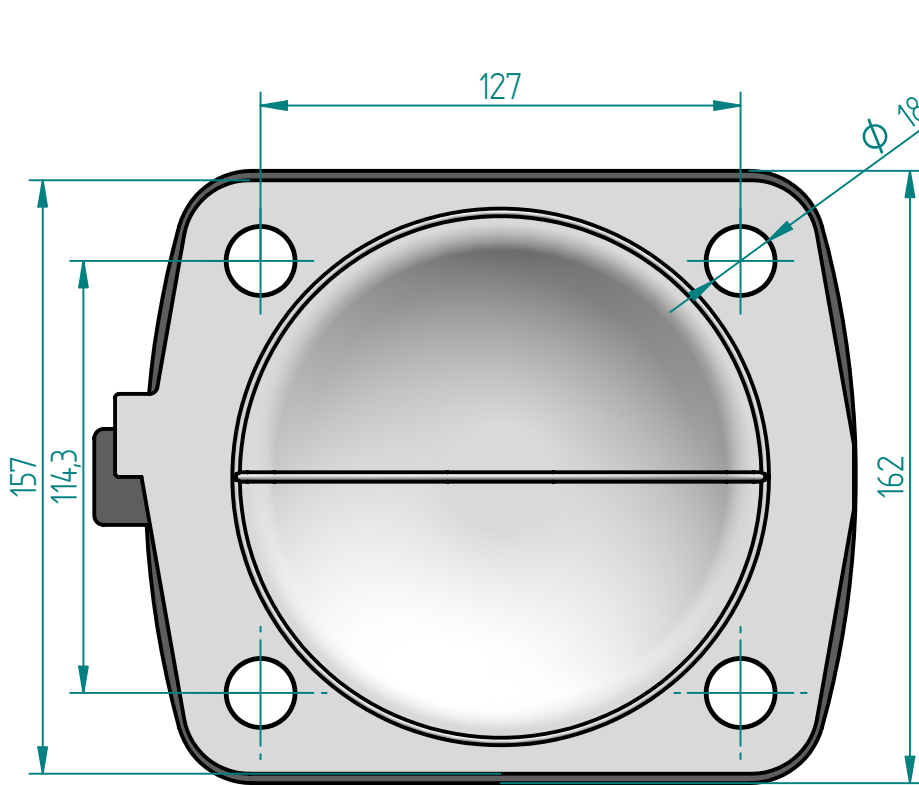
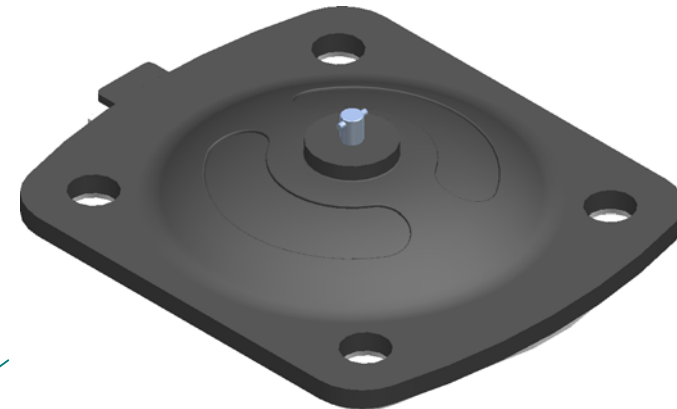
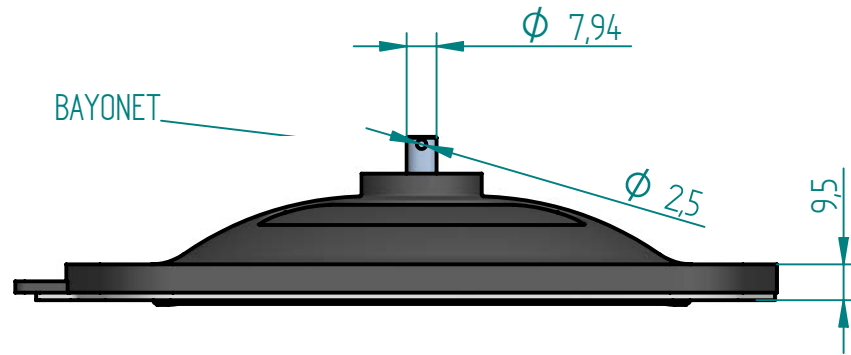

Replacement Diaphragm for :-
 OEM PART = 3.000-P2
 USED ON 3" (DN80) Diaphragm Valve

	NAME	DATE
DRAWN	M. MC KEON	08/21/14
CHECKED		



Material -
EPDM BACKING
TFM-DIAPHRAGM
 Complies with CFR 177.2600
 and Conforms to
 USP Class VI Biological Reactivity
 Tests Section #87 and #88

TITLE DD30-STFM		
SIZE A	FOOT PRINT DIMENSIONS	REV C
FILE NAME: DD30-STFM.dft		
SCALE: 1:2 (mm)	ECO:0605	SHEET 1 OF 1

Disclaimer - Diaphragm Direct® does not manufacture, represent, nor sell OEM valves or diaphragms manufactured by any other company. Diaphragm Direct® brand diaphragms are not sponsored by any other manufacturers. Any name, model, part number, brand, image, material or referral is for descriptive purposes only. Diaphragm Direct® brand replacement diaphragms are guaranteed to fit OEM equipment and meet or exceed OEM specifications. Diaphragm Direct® brand replacement diaphragms are covered by the standard Diaphragm Direct® limited product warranty.