

TK IN-LINE Dimensions

TK- IN LINE for pipe standard according ASTM A269 / 270

Hygienic device may be clamp connected or orbital welded onto a piping system to have no dead leg. It allow the installation to any Clamp connectable equipment or sealed with a standard blind cap.

Advantages :

- Eliminate dead leg
- No product entrapment
- Flexible, fast and easy to adjust different equipment
- No air pokets during sterilisation
- Customized for your needs

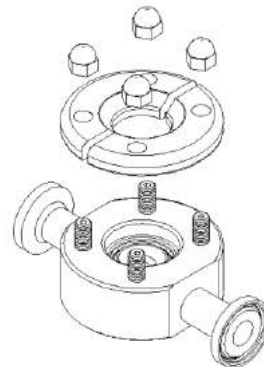
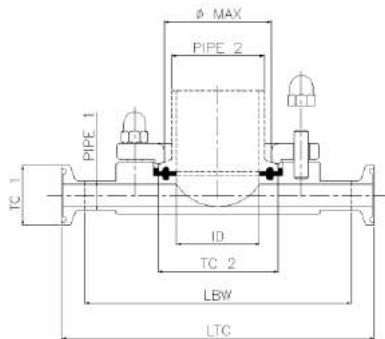

dimensions table

CODE	TC 2	Pipe 2	TC 1	Pipe 1	ID	φ max	L TC	L BW	bolts
TKL-AHAG-12A	25,0	19,05 x 1,65	25,0	12,7 x 1,65	15,75	20,0	101,6	101,6	4 x M6
TKL-AMAG-12A	50,4	38,1 x 1,65	25,0	12,7 x 1,65	34,8	45,0	127,0	127,0	4 x M8
TKL-AHAH-12A	25,0	19,05 x 1,65	25,0	19,05 x 1,65	15,75	20,0	101,6	101,6	4 x M6
TKL-AMAH-12A	50,4	38,1 x 1,65	25,0	19,05 x 1,65	34,8	45,0	127,0	127,0	4 x M8
TKL-AMAJ-12A	50,4	38,1 x 1,65	50,4	25,4 x 1,65	34,8	45,0	127,0	127,0	4 x M8
TKL-AMAM-12A	50,4	38,1 x 1,65	50,4	38,1 x 1,65	34,8	45,0	127,0	127,0	4 x M8
TKL-ANAM-12A	64,0	50,8 x 1,65	50,4	38,1 x 1,65	47,5	57,0	139,7	139,7	4 x M8
TKL-ANAN-12A	64,0	50,8 x 1,65	64,0	50,8 x 1,65	47,5	57,0	139,7	139,7	4 x M8

code **A** = TC clamped code **B** = BW butt weld

Operating conditions :

Design Pressure -1bar to 7 barg (-14,5 psi to 101,5 psi)
Design temperature -80°C to 200°C (-112°F to 392°F)

Material :

Welding flange ASTM A 479 / ASTM A 182 – 316L
Locking ring ASTM A 479 / ASTM A 182 – 316L
bolts ASTM A 193 B8 – 304
nuts ASTM A 194 8-304

Surface finish :

Product contact surface are finish Ra<0,5 micron or better

Marking:

Each TK-Connection in-line is marked with Heat No. for full lot traceability



К-ТЕП — Асептические соединения для емкостей

<http://k-tep.com.ua/>

✉ k-tep@ukr.net

■ Office +38 044 2091823

■ МТС +38 066 9076563

■ Киевстар +38 098 3676414

Skype: [k-teppumps](#)



Замечания

Условия поставки: DDP склад г. Киев

Заметки

Время поставки рассчитано согласно дате предложения и изменяется в зависимости от даты подтверждения заказа.

Размещая заказ, покупатель принимает предложение и все спецификации, характеристики и условия, указанные в данном документе.